

University of British Columbia

Social Ecological Economic Development Studies (SEEDS) Sustainability Program

Student Research Report

# East Mall Redesign between Agronomy and W16th Avenue

Prepared by: Rocky Chen, Allan Fan, Lilian Vuong, Grace Wang, Cecilia Yuen, Fiona Zhang

Prepared for:

Course Code: CIVL 446

University of British Columbia

Date: 12 April 2021

*Disclaimer: "UBC SEEDS Sustainability Program provides students with the opportunity to share the findings of their studies, as well as their opinions, conclusions and recommendations with the UBC community. The reader should bear in mind that this is a student research project and is not an official document of UBC. Furthermore, readers should bear in mind that these reports may not reflect the current status of activities at UBC. We urge you to contact the research persons mentioned in a report or the SEEDS Sustainability Program representative about the current status of the subject matter of a report".*



UBC Social Ecological Economic Development Studies (SEEDS) Sustainability Program

Student Research Report

**East Mall Redesign between Agronomy and W16th Avenue**

**Rocky Chen**

**Allan Fan**

**Lilian Vuong**

**Grace Wang**

**Cecilia Yuen**

**Fiona Zhang**

**University of British Columbia**

**CIVL 446**

**April 12, 2021**

*Disclaimer: "UBC SEEDS Sustainability Program provides students with the opportunity to share the findings of their studies, as well as their opinions, conclusions and recommendations with the UBC community. The reader should bear in mind that this is a student research project/report and is not an official document of UBC. Furthermore, readers should bear in mind that these reports may not reflect the current status of activities at UBC. We urge you to contact the research persons mentioned in a report or the SEEDS Sustainability Program representative about the current status of the subject matter of a project/report".*

## **EXECUTIVE SUMMARY**

As requested by the UBC Social Ecological Economic Development Studies (SEEDS) Sustainability Program, Team 16 has prepared a detailed design report for the East Mall Redesign Project. The objective of this project is to create a safe environment for all road users along East Mall between West 16th Avenue and Agronomy Road at the UBC Vancouver Campus. This report intends to expand on the preliminary design by showcasing the general road layout and details of the proposed upgrades on East Mall.

Virtual site investigations through Google Map and Google Earth were conducted at the beginning of the project to better understand the current road alignments. The key issues and considerations in the development of the design include safety concerns regarding vehicle speeding and pedestrian crossing, collision accidents between parking vehicles and cyclists, overdemand of curbside parking space for field pick-up and drop-off activities, and abundance of asphalt road surface.

Taking into account design constraints at the project site, some key design features were developed.

These features include two protected bike lanes (one on each side of East Mall), sheltered bus stops on Eagles Drive, additional crosswalks with push activated blinking lights and speed tables, adjustments of on-street parking, and provision of Silva Cells in the median to improve local drainage capacity. In order to provide pedestrian weather protection, a comprehensive design of a canopy along East Mall has been established using HS152x252x9.5, W155x0.5 steel, 10mm cable, and ¾" glass.

Team 16 recommends UBC SEEDS to move forward to the implementation phase of the proposed road redesign. A set of Issued for Construction (IFC) drawings are enclosed in the report. The expected consulting fee for the project is \$414,790 including 8% contingency. The estimated capital cost and maintenance cost is \$4,247,263 including 8% contingency. One year has been planned for permit acquisition so that construction begins as early as May 3, 2021, which leads to an approximate end date of October 14, 2022.

# TABLE OF CONTENTS

<b>EXECUTIVE SUMMARY</b>	1
<b>1.0 INTRODUCTION</b>	5
1.1 Project Overview	5
1.2 Project Background	5
1.3 Geographic Location of Site	5
1.4 Project Scope	7
<b>2.0 DESIGN STATEMENT</b>	9
2.1 Key Issues	9
2.2 Design Criteria	10
2.2.1 Non-negotiable Criteria	10
2.2.1.1 Design Standards	10
2.2.1.2 Technical Requirements	11
2.2.1.3 Health and Safety Risks	11
2.2.2 Negotiable Criteria	11
2.2.2.1 Technical Requirements	11
2.2.2.2 Economic Aspects	11
2.2.2.3 Aesthetic and Environmental Considerations	11
2.2.2.4 Cultural and Societal Considerations	12
2.3 Safety Analysis	12
2.4 Preferred Design	13
<b>3.0 TECHNICAL CONSIDERATIONS</b>	14
3.1 Software Packages	14
3.2 Standards and Construction Specifications	14
<b>4.0 KEY DESIGN COMPONENTS</b>	15
4.1 East Mall Alignment	17
4.2 Cross-section Layout	17
4.3 Silva Cells	17
4.4 Agronomy Road	17
4.4.1 Agronomy Intersection Design Features	17
4.4.2 Agronomy Intersection Design Rationale	18
4.5 Thunderbird Boulevard	18
4.5.1 Thunderbird Intersection Design Features	18
4.5.2 Thunderbird Intersection Design Rationale	19
4.6 Eagles Drive	19
4.6.1 Eagles Intersection Design Features	19
4.6.2 Eagles Intersection Design Rationale	20
4.7 Stadium Road	20

4.7.1 Stadium Intersection Design Features	20
4.7.2 Stadium Intersection Design Rationale	21
4.8 Street Parking Zones and Regulations (Rocky)	21
4.9 Crosswalk Speed Tables	22
4.10 Covered Bus Stops	22
4.11 UBC Security Poles	22
4.12 Street Lights Upgrades	23
4.13 Canopy	23
4.13.1 Canopy Design Features	23
4.13.2 Canopy Design Rationale	25
<b>5.0 COMPUTER MODELLING ANALYSIS</b>	<b>26</b>
<b>6.0 STRUCTURAL ANALYSIS</b>	<b>27</b>
<b>7.0 ENVIRONMENTAL MANAGEMENT</b>	<b>29</b>
7.1 Stormwater Management	29
7.2 Utility Management	30
7.3 Waste Management	31
7.4 Noise and Air Pollution Control	31
<b>8.0 STAKEHOLDER MANAGEMENT AND PERMITTING</b>	<b>32</b>
8.1 Key Stakeholders	32
8.2 Stakeholder Engagement and Consultation Plan	33
8.2.1 Project Stakeholders	33
8.2.2 Local Residences and Businesses	33
8.2.3 First Nations and Indigenous Groups	34
8.2.4 Virtual Engagements	34
8.3 Permits	34
<b>9.0 CONSTRUCTION PLANNING</b>	<b>35</b>
9.1 Construction Schedule	35
9.2 Construction Methodology	36
<b>10.0 MAINTENANCE</b>	<b>37</b>
<b>11.0 RISK MITIGATION OF CONSTRUCTION</b>	<b>38</b>
<b>12.0 COST ESTIMATE</b>	<b>40</b>
<b>13.0 REFERENCES</b>	<b>41</b>
<b>Appendix A: Detailed Design Drawings</b>	
<b>Appendix B: Synchro Results</b>	
<b>Appendix C: Structural Analysis Results</b>	

**Appendix D: Safety Analysis Risk Register**

**Appendix E: Cost Estimates**

**Appendix F: Construction Schedule**

**Appendix G: Construction Specifications**

## **1.0 INTRODUCTION**

### **1.1 Project Overview**

This project is a redesign of East Mall located between W16th Avenue and Agronomy Road at UBC. The objective of the project is to create a safe and sustainable transportation environment for all road users. The redesign of East Mall has been tailored to meet design requirements specified by the client, UBC SEEDS.

### **1.2 Project Background**

East Mall is one of the main passages used by many road users which is located along numerous sports fields on the UBC campus. It provides access to the Thunderbird Stadium, the UBC Tennis Centre, and the UBC Baseball Field. On weekdays, hundreds of personal vehicles travelling to Thunderbird Parkade and Health Science Parkade utilize East Mall. Neighbourhood cyclists travel along East Mall very frequently, whether they are cyclists travelling to or from nearby residences, such as Thunderbird and Westbrook Residences, or the Pacific Spirit Park. The sports fields along East Mall experience high volume of pick-up/drop-off vehicles during the spring and summer seasons. The Thunderbird Stadium, located on the south-west corner of East Mall, induces high traffic flow produced by populated events and activities.

### **1.3 Geographic Location of Site**

The focus of the road redesign includes the Thunderbird Fields, Thunderbird Stadium, and the residential neighborhood along East Mall as shown in Figure 1. This segment is approximately 870 metres long and 26 metres wide. Residential areas are located along the west side of East Mall while sportfields and tennis bubbles are located along the east side of East Mall. There is a lane reserved for street parking on both sides of East Mall. A zoomed-out view of the East Mall segment relative to the entire UBC campus is shown in Figure 2.



Figure 1: Segment of the Redesign Annotated in Red (Captured on Google Earth)



Figure 2: Location of East Mall Segment Relative to UBC Campus (Captured on Google Earth)



## 1.4 Project Scope

The project scope includes analyses of multi-modal level of services for the projected traffic volume along East Mall, a safety and risk analysis, an engagement and consultation plan, technical drawings for the proposed redesign, a Class C cost estimate and a projected construction schedule. Each team member’s responsibilities and contributions have been summarized in Table 1.

The road redesign aims to:

- Ensure safety of all roadway users,
- Prioritize pedestrian, cycling, and transit over personal vehicles,
- Accommodate high demand of pick-up/drop-off and high traffic volume during stadium events,
- Improve livability by reducing vehicle travel speeds and improving pedestrian crossing safety,
- Accommodate projected population growth on campus and future development of campus facility, especially at the south end of East Mall in front of the future Stadium Neighbourhood,
- Compensate for stormwater management and incorporate green infrastructure to retain rainwater on site,
- Provide weather protection by constructing a covered pedestrian walkway along Agronomy Road, and
- Minimize costs.

*Table 1: Summary of Team Roles and Contributions*

Team Member	Roles and Contributions
Rocky Chen	<ul style="list-style-type: none"> <li>● Canopy Structure               <ul style="list-style-type: none"> <li>○ Design Criteria</li> <li>○ Design Outputs/Drawings</li> <li>○ Material Research</li> <li>○ Structural Analysis</li> </ul> </li> <li>● Construction Cost Estimating</li> <li>● Maintenance Cost Estimating</li> <li>● Maintenance Plan</li> <li>● Construction Schedule &amp; Methodology</li> <li>● Communications Liaison</li> <li>● AutoCAD Design               <ul style="list-style-type: none"> <li>○ Canopy Detailed Drawing</li> </ul> </li> </ul>

Allan Fan	<ul style="list-style-type: none"> <li>● UBC Policy/ Design Objectives</li> <li>● Conceptual Design <ul style="list-style-type: none"> <li>○ Pedestrian Considerations</li> </ul> </li> <li>● Standards</li> <li>● Construction Specifications</li> <li>● Safety Analysis</li> </ul>
Lilian Vuong	<ul style="list-style-type: none"> <li>● Conceptual Design <ul style="list-style-type: none"> <li>○ Intersection Control Design</li> </ul> </li> <li>● Computer Modelling Analysis <ul style="list-style-type: none"> <li>○ Synchro &amp; SimTraffic</li> </ul> </li> <li>● AutoCAD Design <ul style="list-style-type: none"> <li>○ Roundabout Intersection</li> <li>○ Eagles Dr Redesign</li> <li>○ East Mall Alignment</li> </ul> </li> <li>● Stakeholder Management</li> <li>● Report Editor, Reviewer and Formatter</li> </ul>
Grace Wang	<ul style="list-style-type: none"> <li>● Conceptual Design <ul style="list-style-type: none"> <li>○ Cost Efficient Design</li> </ul> </li> <li>● Design Criteria <ul style="list-style-type: none"> <li>○ Bicyclist Protection</li> <li>○ City of Vancouver Standard Details</li> </ul> </li> <li>● AutoCAD Design <ul style="list-style-type: none"> <li>○ Agronomy Rd Redesign</li> <li>○ General Notes</li> </ul> </li> <li>● Risk Mitigation Analysis</li> <li>● Canopy Structure <ul style="list-style-type: none"> <li>○ Structural Analysis</li> </ul> </li> <li>● Consultant Schedule</li> <li>● Report Editor</li> </ul>
Cecilia Yuen	<ul style="list-style-type: none"> <li>● Design Criteria <ul style="list-style-type: none"> <li>○ Minimum Lane Widths</li> </ul> </li> <li>● Conceptual Design <ul style="list-style-type: none"> <li>○ Cross-section Dimensions</li> </ul> </li> <li>● AutoCAD Design <ul style="list-style-type: none"> <li>○ Signalized Intersection</li> <li>○ Thunderbird Blvd Redesign</li> </ul> </li> <li>● Canopy Structure <ul style="list-style-type: none"> <li>○ Structural Analysis</li> <li>○ Design Outputs</li> </ul> </li> <li>● Parking Layout and Regulation</li> <li>● Maintenance Plan</li> <li>● Construction Schedule &amp; Cost</li> <li>● Report Editor</li> </ul>
Fiona Zhang	<ul style="list-style-type: none"> <li>● Environmental Management</li> <li>● Silva Cells Product Research</li> <li>● AutoCAD Design <ul style="list-style-type: none"> <li>○ Utilities</li> <li>○ Standard details</li> <li>○ Road alignment and cross-sections</li> </ul> </li> <li>● Cost Estimate</li> <li>● Report Editor and Reviewer</li> </ul>

## 2.0 DESIGN STATEMENT

### 2.1 Key Issues

The road design of East Mall currently consists of two-lane vehicle traffic, two unprotected bike lanes, street parking and pedestrian sidewalks as shown in Figures 3 and 4. The following issues associated with the current design have been identified. It is the top priority to address these concerns in the redesign of East Mall to ensure environmental sustainability and safety of all road users, especially the cyclists and pedestrians.



*Figure 3: South Street View of East Mall Intersecting Agronomy Rd (Captured on Google Earth)*



*Figure 4: North Street View of East Mall and Stadium Rd Intersection (Captured on Google Earth)*

Lack of support for modes of active transportation:

- Walking:

High volumes of pedestrians have been observed along East Mall, especially at the intersections, pedestrian crosswalks and bus stops. The traffic signages in place are not effective enough to limit vehicle speeding which poses a threat on pedestrian safety.

- Cycling:

The bike lanes along East Mall are currently unprotected. In addition, they are located directly in between the vehicle travel lanes and on-street parking lanes. This induces the risks of collisions between cyclist and drivers parking on-street.

Lack of temporary parking spaces for pick-up and drop-off activities:

- East Mall experiences a high demand of pedestrian crossing, pick-ups and drop-offs along the road due to field activities.

Due to the overdemand of parked vehicles during peak hours, drivers have been spotted dangerously pulling over and utilizing the bike lanes for pick up and drop off purposes.

Abundance of asphalt road surface:

- Standard asphalt surface results in higher volume of runoff entering the sewer system compared to permeable surfaces. This would eventually lead to combined sewer overflows during heavy rainfall events and cause water pollution.

## **2.2 Design Criteria**

The design criteria of this project has been identified into two categories: non-negotiable and negotiable criteria. The design will adhere to the design criteria listed in this section.

### **2.2.1 Non-negotiable Criteria**

#### **2.2.1.1 Design Standards**

The design will follow the applicable provincial and federal design standards, guidelines and bylaws. The following will be referred to throughout the development of the road redesign:

- Geometric Design Guide for Canadian Roads from Transportation Association of Canada (TAC);

- British Columbia Active Transportation Design Guide from the Ministry of Transportation and Infrastructure (MOTI);
- UBC Transportation Plan.

### *2.2.1.2 Technical Requirements*

The design will accommodate future developments; this includes the road alignment in front of the future Stadium Neighbourhood as well as the anticipated traffic volumes on East Mall. Green infrastructure has also been incorporated into the design to achieve environmental sustainability goals identified by UBC SEEDS.

### *2.2.1.3 Health and Safety Risks*

To prioritize the safety of all road users, specifically pedestrians and cyclists, the maximum allowable travelling speed of vehicles will be reduced. The optimal speed will be determined through traffic analysis. The sightlines and crossing conditions will also be analyzed in order to reduce risks and improve pedestrian safety.

## *2.2.2 Negotiable Criteria*

### *2.2.2.1 Technical Requirements*

Intersection control types have been designed with the consideration of future traffic volumes, safety and satisfaction of all road users. The method and schedule of construction are taken into account to minimize impacts, such as dust and noise, to UBC and neighbouring communities.

### *2.2.2.2 Economic Aspects*

The cost is a critical consideration to this project. One of the design objectives is to minimize the costs while also accomplishing project goals. The cost of constructing a tunnel and canopy structure were considered during the decision process of the preferred design.

### *2.2.2.3 Aesthetic and Environmental Considerations*

The redesign of the road conforms with the existing architecture, maintains the wilderness aesthetic in the local environment, and accommodates future development plans in UBC. The noise level and air quality during construction need to be considered at the same time.

#### 2.2.2.4 Cultural and Societal Considerations

The general UBC community, the University Neighbourhood Association, the University Endowment Lands (UEL), and the First Nations Groups will be consulted during the design process. Stakeholder engagement is crucial to ensure stakeholder interests are considered and addressed to a level of satisfaction. Some topics may include land use, air quality, and noise production during and after the project construction.

### 2.3 Safety Analysis

A safety analysis was completed using a risk register and risk matrix by evaluating potential hazards associated with the detailed design. A score was issued to each potential hazard based on the severity and impact of the event using a scale from 1 to 5. The calculated severity is the product of the two scores. The scoring was completed twice to compare and contrast the differences between the original road design and the detailed design. Table 2 and 3 shows the risk matrices used for the safety analysis. Refer to Appendix D for the safety analysis risk register.

Table 2: Risk Matrix of Current Configuration

		IMPACT				
		Negligible 1	Low 2	Medium 3	High 4	Extreme 5
P R O B A B I L I T Y	Almost Certain 5					
	Likely 4				5	
	Moderate 3				1, 2, 4, 9	3, 8
	Unlikely 2			6, 7		
	Rare 1					

Table 3: Risk Matrix of Proposed Design

		IMPACT				
		Negligible 1	Low 2	Medium 3	High 4	Extreme 5
P R O B A B I L I T Y	Almost Certain 5					
	Likely 4					
	Moderate 3					
	Unlikely 2			9	2, 4, 5	
	Rare 1		3	6, 7	1	8

The two risk matrices show a visual comparison of the nine hazards identified in the risk register. For most hazards, a risk reduction mitigation strategy was implemented to reduce its likelihood. For example, hazard 1 represents the risk of a cyclist and vehicle conflict along East Mall. The original road design included painted bike lanes along the majority of East Mall; the likelihood of this event is relatively high. With the addition of bike protection curbs in the detailed design, hazard 1 is largely mitigated as a physical curb separates the lanes for the two types of road users. Results from the safety analysis shows that the detailed design largely accounts for nearly all general hazards.

## 2.4 Preferred Design

During preliminary design, it was determined that the “multi-modal design” best satisfies the above design criteria. UBC’s vision is to achieve two-thirds of all trips to and from the campus by walking, cycling, and transit as specified in the 2014 Transportation Plan. It is outlined that each neighbourhood should have a fine-grained pedestrian and cycle route network with mid-block connections. The chosen design layout most equitably aligns with UBC’s vision. The detailed design includes three additional crosswalks in the midpoint between Stadium Road/W16th Avenue, Eagle Drive/Stadium Road, and Thunderbird Boulevard/Eagle Drive. Speed tables and push button activated lights are added to the crosswalk infrastructure to achieve traffic calming measures, which addresses issues with vehicle

speeding and improves safety for pedestrians. The speed tables combined with reduced allowable vehicle speed limits to 40km/hr (from 50km/hr) will prioritize the safety of all road users, particularly pedestrians and cyclists.

Another active mode of transportation that is prioritized is cycling. The implementation of protected bicycle lanes on East Mall will meet the need for a North-South connection bike route that allows for cyclists access from W16th Avenue. In addition to traffic calming, the multi-modal design can provide a much-needed expansion to the UBC's cycling network. Population growth is also taken into consideration by assuming that there will be a 20% reduction in single occupant vehicle travel to and from UBC based on the 1996 levels. This assumption is outlined in Target 2 of the UBC Transportation Plan. Section 4.0 will elaborate on the key components of the proposed design.

### **3.0 TECHNICAL CONSIDERATIONS**

#### **3.1 Software Packages**

The software packages used in the design and planning processes are AutoCAD, Synchro, SAP2000, and Microsoft Excel. AutoCAD has been used as the drafting software for plan view and cross-section drawings. The canopy drawings have also been drafted using AutoCAD. Synchro and SimTraffic was used earlier in the design phase to simulate different traffic volumes and the efficiency of the proposed and candidate intersection types, refer to Section 5.0 of the report for the software outputs. SAP2000 was used for the structural analysis of the Canopy structure which is detailed in Section 6.0. Excel spreadsheets were created in the construction schedule development and the cost estimate.

#### **3.2 Standards and Construction Specifications**

The standards and codes that the design and specifications will reference are the CSA, specifically section A23.1, as well as the Construction Specifications Manual from the City of Vancouver which correspond with Master Municipal Construction Documents. The purpose of referencing and using these standards, specifications and procedures are to ensure the quality of construction work for this project is in



accordance with the best available standards to minimize maintenance requirements and reduce life cycle costs. This report includes construction specifications, in Appendix G, for concrete, asphalt, and road fill to supplement the general notes on the first page of the IFC package.

## **4.0 KEY DESIGN COMPONENTS**

### **4.1 East Mall Alignment**

The East Mall alignment, as shown in Drawing C1 in Appendix A, illustrates the overall layout of the road redesign between Agronomy Road and W16th Avenue. As per client's request, the road alignment was redesigned to keep East Mall consistently straight. By analyzing traffic data provided by the client, each intersection along East Mall was carefully designed to accommodate future traffic flows. The overall redesign focuses on improving safety for all road users and promoting active transportation. Parking zones and regulations have also been incorporated along East Mall to accommodate pick-up and drop-off from Stadium activities. As labelled in the detailed drawing, the speed limit between Thunderbird Boulevard and W16th Avenue has been reduced from 50 km/hr to 40 km/hr to ensure the safety of all road users. This drawing indicates the location of road infrastructure as well as the canopy structure at the corner of Agronomy Rd and East Mall intersection to serve as an overhead weather protection for pedestrians. Key design features are described in detail in the following sections.

### **4.2 Cross-section Layout**

Two typical cross-sections are illustrated in Drawing C2 and C3 in Appendix A. The proposed lane configuration is outlined in Table 4, with the exception of the Agronomy Road block which does not have on-street parking lanes or median. With limited information provided, the approximate locations of underground utilities are also outlined on these two drawings. As such, the contractor will be responsible for carrying out BC One Call and locate the utilities in the field before the commencement of construction.

Table 4: Proposed Lane Configuration northbound and southbound of East Mall

Design	Typical Lane Width	Description	Reference
Sidewalks	6.5 m	1.5 m pedestrian through zone, frontage zone with various width	BC Active Transportation Design Guide
Uni-directional Protected Bicycle Lanes	2.5 m	bicycle zone, separated from vehicle parking and travel lanes with 1.4 m street buffer zone	BC Active Transportation Design Guide
Parking Lanes	2.7 m	-	Same as the current lane width measured from the provided AutoCAD drawing
Vehicle Lanes	3.2 m	-	TAC Geometric Design Guide
Median	4.2 m	-	Adjusted to accommodate the proposed configuration

### 4.3 Silva Cells

Silva Cells are a modular soil containment system. It acts similarly to a suspended pavement system that transfers the road loading to the compacted subbase below the cells. This enables trees to flourish in the lightly compacted soil contained in the cells. Silva Cells also provide efficient on-site stormwater retention and treatment with a reduction rate of up to 71% biochemical oxygen demand, 92% metal and 96% total suspended solids in the surface runoffs (Deeproot, 2021). After rain water is retained in the soil pore space or absorbed by the trees, soil filters the remaining rain water and removes excess nutrients before it is discharged to the sewer system through an underdrain pipe at the base of the Silva Cells, as illustrated in Figure 5. This process reduces the amount of polluted surface runoff entering the sewer system and eventually the water bodies as combined sewer overflow. Another advantage of Silva Cells is its low maintenance requirement. Periodic cleanout is required for the piping system while annual landscape maintenance and irrigation is required for the trees.

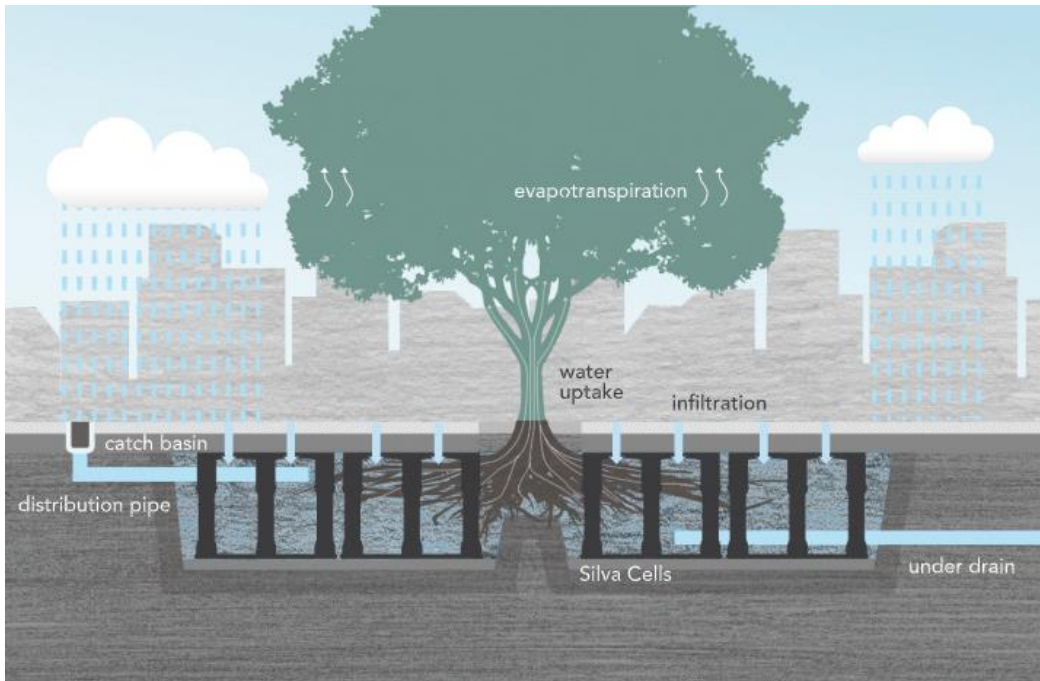

Figure 5: Silva Cells Configuration ([Source](#))

A typical cross-section incorporating Silva Cells below the median is shown on Drawing C13 in Appendix A. The installation of Silva Cells will require uprooting and replanting of the existing trees. An arborist should be consulted to develop proper operation and maintenance procedures to ensure the survival of trees after being replanted. A green infrastructure design specialist should be retained to size the Silva Cells and design the tie-ins to the existing storm sewer system. This will require as-built drawings and design reports of the existing storm sewer system to assess the performance of the existing system and to determine the required capacity of the Silva Cells that will be incorporated into the proposed system.

## 4.4 Agronomy Road

### 4.4.1 Agronomy Intersection Design Features

The intersection at Agronomy Road and East Mall remains largely the same as the current condition. In order to provide a safer environment for cyclists, 2.5 metres of painted travel lanes exclusively for bicycle use are added on both the northbound and the southbound of the road and are delineated by painted lines. The pedestrian sidewalks will have similar outlines as the existing condition but with expanded widths to

ensure pedestrian safety and promote multi-modal travel methods. The south end of the Agronomy block is divided into two vehicle lanes in the southbound direction to facilitate the transition to the added right turn and left turn lanes. The road configuration is shown in Drawing C4 under Appendix A.

#### 4.4.2 Agronomy Intersection Design Rationale

The design at the Agronomy Intersection is restricted by the limited space between the property lines on both sides of the road. The intersection originally has an LOS of A during AM peak hours and an LOS of B during PM peak hours, which indicates that minimal changes are needed. The intersection control type will continue to serve as a 4-way stop. The painted bicycle lanes and expanded sidewalks are added in order to provide a safer travelling environment for all road users and to achieve consistency with the new design features for the other parts of East Mall.

### 4.5 Thunderbird Boulevard

#### 4.5.1 Thunderbird Intersection Design Features

The Thunderbird Blvd intersection will continue to serve as a four-way signalized control type. Right turn lanes on both directions of East Mall and a left turn lane on the southbound will be added. This improves the traffic flow at the intersection of Thunderbird Boulevard and East Mall. To account for the additional northbound right turn lane, the sidewalk at the intersection will be shrunk, while the location of the pedestrian crosswalk will remain the same. The speed limit is designed to be 40km/hr after passing the Thunderbird Boulevard intersection on the Southbound of East Mall, thus, a speed limit sign of 40km/hr will be added near the intersection to indicate the change of speed limit. With the presence of the emergency driveway in front of the UBC Tennis Centre, 6 metres will be reserved on both sides of the driveway to accommodate the access of emergency vehicles. An additional raised crosswalk has also been added just south of the emergency driveway. This will provide an access point for the residences and tennis centre. The intersection of Logan Lane and East Mall will remain controlled by a stop sign since Logan Lane has low traffic volume and nearby residences are expected to have minimal population changes. The existing bus stop will be moved from the south to the north side of Eagles Drive, with a

short bus lane starting from the northbound exit of roundabout to the bus stop. The new location of the bus stop is indicated in Drawing C6 in Appendix A.

#### **4.5.2 Thunderbird Intersection Design Rationale**

The intersection has a high volume of traffic during peak hours. High volume of vehicle traffic is observed travelling to Thunderbird Parkade at 9:00 AM. Also, at 5:00 PM, a high volume of traffic is observed making left turns from Thunderbird Boulevard to East Mall southbound. With the addition of the turning lanes, the traffic will substantially improve, and thus, improve the LOS of the intersection. As the future traffic flow on East Mall will increase with the development at Stadium neighborhood, these additional lanes can accommodate the increased traffic demand. The bus stops are moved to the north of Eagles Drive due the space constraint from the implementation of roundabouts. The new location of bus stops are also closer to the residential area, this would provide convenience to the residents. The bus will stop in the vehicle parking lane to avoid traffic interruption.

### **4.6 Eagles Drive**

#### **4.6.1 Eagles Intersection Design Features**

The Eagles Intersection has been redesigned from an uncontrolled intersection with one stop sign along Eagles Drive into a three-way roundabout. The diameter of roundabout island is designed to be 18 metres whereas the outer diameter for the vehicle lane is designed to be 28 metres. This results in a 5-metre vehicle lane width which satisfies the design requirement for minimum lane width. Pedestrian crosswalks have been introduced on the north, south and west side of the roundabout. Bike buffers and curbs have been extended for the north and south entries of the roundabout in order to merge vehicles into one lane. An additional crosswalk has been added one block south of Eagles Drive along East Mall. The crosswalk features push activated lights and speed tables at curb height. Crosswalk curb extensions have been incorporated for the crossing accordingly. The road configuration for this block is shown in Drawing C8 in Appendix A.

## 4.6.2 Eagles Intersection Design Rationale

The roundabout design is designed for comfortable traffic flow for Eagles Drive while also increasing the safety for all road users. The roundabout has been designed to accommodate emergency vehicles travelling through the roundabout with a suitable clearance for comfortable vehicle travel. The effectiveness of the roundabout design was observed and evaluated using Synchro and SimTraffic software. The location of the crosswalks at the roundabout has been carefully designed for vehicles entering and exiting the roundabout; space is delegated for vehicles merging into the roundabout while ensuring safe pedestrian crossings. The additional crosswalk one block south of Eagles Drive allows pedestrians to cross safely and reduces the likelihood of jaywalking.

The bike lane located on the east side of the intersection is designed to improve cyclist and pedestrian safety; the design decreases the likelihood of pedestrian and cyclist collision by keeping the lanes separated for its respective road user. As shown in Drawing C9 in Appendix A, the width of the pedestrian sidewalk decreases slightly for a short distance to ensure the safety of pedestrians and cyclists. The design of the bike lane merging with the pedestrian sidewalk, located on the west side of Eagles intersection, is to reduce the risk and likelihood of cyclist and vehicle collision. The bike lanes at the roundabout are not separated with the bike buffer due to limited road right of way.

## 4.7 Stadium Road

### 4.7.1 Stadium Intersection Design Features

To account for the proposed Stadium Neighborhood development, the intersection at Stadium Road has been redesigned from an uncontrolled intersection with one stop sign along Stadium Road into a 3-way actuated signalization control type to accommodate the expected local population growth. As shown in Drawings C9 and C10 in Appendix A, the lanes have been shifted just before the intersection on the east side in order to have enough space for a left-turn lane. This was a requirement specified by the client to account for the traffic increase induced by sport events at Thunderbird Stadium. As requested by the client, the total road widths transition from an approximate 34 metres to the restricted 25 metres. Due to this restriction, the median was removed and the curbs have been extended to reflect provided client

drawings. A crosswalk with overhead signals was added in the middle of the block and the crosswalk by W16th Ave remains the same as its original design. Due to space restrictions, the west parking lane transitions into a right turn lane to accommodate the two-lane roundabout.

#### **4.7.2 Stadium Intersection Design Rationale**

Due to the proposed Stadium Neighbourhood construction, the local population growth is expected to increase the traffic volume entering and exiting Stadium Road. Events at Thunderbird Stadium will introduce demand surges during special events. The benefit of having a signalized intersection is the flexibility behind actuation time adjustments that can accommodate various traffic flow volumes.

Implementing a push button for pedestrian crossing also improves accessibility and pedestrian safety. The original intersection design poses a risk on pedestrians and vehicles because of higher possibility of collisions at blind spots. This intersection design is an equitable solution that provides users safe crossing alternatives and mitigates traffic congestion due to the growing population.

#### **4.8 Street Parking Zones and Regulations**

Public pay parking is currently available along the Northbound between Thunderbird Boulevard and W 16th Avenue, and between Eagles Drive and Stadium Road on the Southbound. To accommodate the high volume of pick-up and drop-off activities on the Northbound of East Mall, additional parking will be added on the Southbound between Stadium Road and W 16th Avenue. The current pick-up and drop-off activities are mostly for the users of the fields on the East side of the road. The newly implemented roundabout at Eagles Drive can be utilized to allow road car users to easily access the parking on the Southbound, and the two additional crosswalks along Eagles Drive block and Stadium Road block will allow people to safely cross from the Southbound to the fields. With these additional features, the Southbound can divert the pick-up and drop-off activities and reduce the demand for temporary parking on the Northbound. The street parking between Thunderbird Boulevard and Eagles Drive will remain reserved for Hawthorn resident and visitor permits only. There is no on-street parking between Agronomy Road and Thunderbird Boulevard, as the existing parking lots will be sufficient.

#### **4.9 Crosswalk Speed Tables**

The detailed design proposes the addition of three new pedestrian crosswalks at the midblocks between Eagles Drive, Stadium Road, and Agronomy Road along East Mall that have been labelled in Drawings C4, C8, and C10 respectively in Appendix A. The inclusion of the crosswalk speed tables is twofold. Firstly, these crosswalks are a vital addition to the overall goal of increasing active transportation infrastructure in the area. With the relatively long blocks along this portion of East Mall, additional crosswalks provide supplementary crossing locations to the ones at intersections. To ensure pedestrian crossing safety, overhead push activated signals will be installed to improve visibility. The secondary design goal of the crosswalk speed tables is to address vehicle speeding issues. In conjunction with a lowered speed limit on East Mall, these new speed tables will achieve traffic calming design objectives by creating friction for drivers which also provides pedestrian crossing safety. Painted arrows on the sloped portion of the speed table also improve visibility of the speed tables, giving drivers advanced notice to slow down. The configuration of the speed tables can be referenced in Drawing C13 in Appendix A.

#### **4.10 Covered Bus Stops**

There will be coverings added at the new bus stops that have been relocated to the northern side of Eagles Drive. The covered bus stops will provide weather protection for transit passengers. The shelter configurations, roof styles, material options, and color choices will be aesthetically similar to the other covered bus stops at UBC Vancouver. The bus stop shelters will be prefabricated off site, and the vendor will provide shop drawings for installation purposes. Busses will utilize the on-street parking lane at the location of the bus stop. Crosswalks have been introduced across the bike lanes, providing passengers a safe access between the bus and the pedestrian sidewalk. The visible crossing will increase cyclist awareness while also reducing the risk of cyclist and pedestrian collision.

#### **4.11 UBC Security Poles**

The UBC Vancouver Campus has 43 security phones installed which allows users to easily contact the 24/7 Campus Security Dispatch in case of emergency. To extend the coverage of this service, an



additional security phone, also known as a Blue Phone, is recommended to be installed by the intersection of Stadium Road and East Mall. The location of the installment was decided based on the proposed Stadium Neighbourhood construction as there will be more pedestrians travelling through the area. The additional Blue Phone is a necessary component of the design. All users have the right to feel safe regardless of the time of day. If users feel safe, active transportation modes become more attractive. Users of the adjacent field facilities will also benefit from being able to easily report suspicious activities and have immediate access to medical help when necessary.

#### **4.12 Street Lights Upgrades**

In the interest of improving the visibility along East Mall, streetlights will be retrofitted to new light emitting diodes (LED). The benefits of LED lights include longer life span, brighter streets, and better colour rendering for all road users. This will reduce the possibility of accidents and collisions. Long term, LED lights are known to be energy efficient which could lead to cost saving of up to 70% when compared to high pressure sodium (HPS) lights, according to the Union of B.C. Municipalities. Brighter sidewalks can also serve as a deterrent for crime which is an added benefit to the change. These safety centric design features address design criteria specified by the project client.

#### **4.13 Canopy**

##### **4.13.1 Canopy Design Features**

A canopy, a cantilever suspension hybrid structure, will be constructed around the Gerald McGavin Building. It will span from Agronomy Road to the building entrance located on East Mall, see Figure 6, 7, and 8 for the screenshot of Drawing C1 (Appendix A) for the location of the canopy. The canopy will cover 2.5 metres away from the building and provide weather coverage for pedestrians.



Figure 6: Location of Canopy on East Mall Alignment Drawing



Figure 7: Canopy coverage annotated in red (Captured on Google Earth)



Figure 8: Street view of Gerald McGavin Building along Agronomy Rd (Captured on Google Maps)

The design of the canopy was inspired by the canopy located at the front entrance of UBC's Life Science Building. The canopy has been designed to cantilever off the Gerald McGavin Building 8 feet in height. The canopy frame and suspension cables are designed to mount on the existing concrete slab of the building. The materials used for the canopy includes aluminum frame, steel suspension cables and glass panels that will cover on top of steel frame. The aluminum frames will be constructed using T-Beams sized at WT155x10.5 while the suspension cable will be 10 mm in size. Beams and cables are designed with a spacing of 5 metres on-centre. The canopy will be sloped towards the building at a 1 inch to 8 feet ratio for drainage. A detailed drawing of the canopy design with dimensions has been illustrated in Drawing S1 in Appendix A.



*Figure 9: Precedent example of the canopy design from UBC's Life Sciences Building (Captured on Google Maps)*

#### 4.13.2 Canopy Design Rationale

The canopy has been designed to account for the high volumes of pedestrian traffic, especially bus users from Agronomy Road and Westbrook Mall. Most surrounding buildings in the area have canopy structures (Figure 9) except the Gerald McGavin Building. Therefore, constructing a canopy structure at the Gerald McGavin Building will improve serviceability and building aesthetics.

The design for this canopy structure is cost efficient since the components are readily available in Canada and are available upon order (Metro Performance Glass, n.d.; RONSTAN Tensile Architecture, 2021; J.E.Berkowitz Architectural Glass, n.d.). Aluminum yields a light-weight structure and material sizing can be easily adjusted throughout the detailed design stage. The simplicity of the canopy design improves building aesthetics while also blending with the surrounding architecture.

## 5.0 COMPUTER MODELLING ANALYSIS

Each intersection along East Mall was evaluated through multiple simulations using computer modelling software, such as Synchro and SimTraffic. The client provided volume and speed data between Thunderbird Boulevard and Eagles Drive, and traffic movement data during peak hours for intersections at Agronomy Road, Thunderbird Boulevard, and Stadium Road. Although traffic movement data was not provided for Eagles Drive, it has been assumed that the traffic movement flow for Eagles Drive is projected similarly to Stadium Road; Stadium’s traffic movement data was referenced for the redesign of the Eagles intersection. Realistically speaking, the traffic volume at Stadium Road. would be equal to, or greater than, the traffic volume at Eagles Drive due to Thunderbird Stadium activities.

Using Synchro, the Level of Service (LOS) for each intersection (Agronomy, Thunderbird, and Stadium) was determined by analyzing AM and PM peak hour data between the existing original road design and the preliminary design. Considering the future population growth on campus, a traffic growth factor of 1.0 and 1.3 was applied to both designs. For the control type for each intersection, refer to sections 4.4 - 4.7. Tables 5 and 6 summarizes the results acquired from Synchro. Refer to Appendix B for captured LOS results for each intersection.

*Table 5: Synchro Results for Intersection LOS, Growth Factor 1.0*

Intersection	LOS			
	Original Design		Preliminary Design	
	AM	PM	AM	PM
<b>Agronomy Rd</b>	A	B	A	B
<b>Thunderbird Blvd</b>	B	B	A	B
<b>Stadium Rd</b>	D	C	A	A

Table 6: Synchro Results for Intersection LOS, Growth Factor 1.3

	LOS			
	Original Design		Preliminary Design	
Intersection	AM	PM	AM	PM
Agronomy Rd	B	B	B	B
Thunderbird Blvd	C	B	B	B
Stadium Rd	F	E	A	A

A roundabout intersection was designed for Eagles Drive. However, it was determined through research that Synchro is not the best software for modelling roundabouts. Instead, SimTraffic, an extension software, was used to analyze the roundabout design at Eagles Drive by noting any traffic related issues at the intersection. After numerous simulations, a roundabout design was found feasible as no traffic congestion was noted and the traffic network remained unaffected. Our team recommends a traffic analyst expert with access to costly traffic softwares for a more thorough and detailed analysis of the roundabout design.

## 6.0 STRUCTURAL ANALYSIS

The canopy structure was analyzed in SAP2000 to obtain the anticipated deformed shape and structural demands. The SAP2000 model is shown in Figure 10, where element 1 is the steel T-beam and element 2 is the cable. The weight of the glass is converted into a uniformly distributed load in SAP2000 to be 0.84kN/m. At the connection of T-beam and Hollow Square Section, node 1 in the model, it is modelled as fixed support as the T-beam would be welded into the HSS. Also, the connection of the cable and the wall, node 3, is modelled as pin support in SAP2000. The result of the structural analysis on SAP2000 is shown in Figure 11.

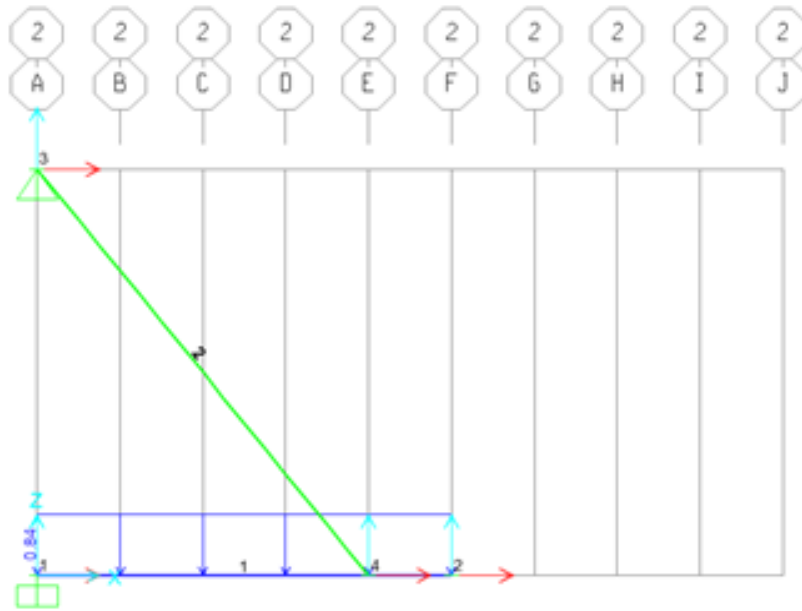

Figure 10: SAP2000 Canopy Model

Frame Text	Station m	OutputCase	CaseType Text	P KN	V2 KN	V3 KN	T KN-m	M2 KN-m	M3 KN-m	FrameElem Text	Ele
1	0	COMB1	Combination	-8.516	-5.937	0	0	0	0.399	1-1	
1	0.5	COMB1	Combination	-8.516	-2.664	0	0	0	2.5492	1-1	
1	1	COMB1	Combination	-8.516	0.609	0	0	0	3.063	1-1	
1	1.5	COMB1	Combination	-8.516	3.881	0	0	0	1.9406	1-1	
1	2	COMB1	Combination	-8.516	7.154	0	0	0	-0.8182	1-1	
1	2	COMB1	Combination	0	-3.273	0	0	0	-0.8182	1-2	
1	2.5	COMB1	Combination	0	-4.41E-14	0	0	0	5.697E-15	1-2	
2	0	COMB1	Combination	142.385	0	0	0	0	0	2	
2	1.60078	COMB1	Combination	142.214	0	0	0	0	0	2	
2	3.20156	COMB1	Combination	142.043	0	0	0	0	0	2	

Figure 11: Canopy SAP2000 Structural Analysis Result

The capacities of different structural components were done on the Excel spreadsheet, see Appendix C Canopy Structural Analysis for the detailed calculation. The modes of loading include wind load, snow load, and dead load from self-weight. Different load combinations for Ultimate Limit States were

analyzed in the design, and the load combination of 1.25D + 1.5S is found to be governing. Four failure modes were governing: Cable tension failure, T-Beam bending failure, T-Beam shear failure, and welding connection failure between T-beam and Hollow Square Section. After computing the structure resistance on the four failure modes above, the result proves the structure is designed to standards of the National Building Code of Canada (Canadian Commission on Building and Fire Code, 2019). The capacity and demands of the structure are summarized in Table 7.

*Table 7: Summary of Structural Analysis*

	<b>Demands</b>	<b>Capacity</b>
<b>Axial Load in Cable</b>	142 kN	150 kN
<b>Shear Force in T-Beam</b>	7.1 5kN	161 kN
<b>Moment in T-Beam</b>	3.06 kNm	8.51 kNm

## **7.0 ENVIRONMENTAL MANAGEMENT**

### **7.1 Stormwater Management**

UBC's Integrated Stormwater Management Plan is in place to ensure its storm sewer system abides by applicable water quality regulations, including the Federal Fisheries Act, the Canadian Environmental Act, and the BC Water Act and Environmental Management Act. Stormwater on the UBC campus is drained through four principal catchments, North, West, 16<sup>th</sup> Avenue and South catchments. As outlined in red in Figure 12, the project area is located in UBC's 16<sup>th</sup> Avenue Catchment and West Catchment and stormwater is discharged into a creek in Pacific Spirit Park and a creek along Trail 7 leading to Wreck Beach. According to the Integrated Stormwater Management Plan, these two catchments are not subject to flooding risk and future land use change and climate change is anticipated to have minimal change to the volume of stormwater required to be collected. However, most of UBC's stormwater is surface runoff, which is a source of water pollution and raises concern about water quality. Surface runoff is excess stormwater that cannot be absorbed due to the abundance of impervious road surface and transports sediments, metals, substrate requiring biochemical oxygen demand and numerous other contaminants. UBC's storm sewer system is separated from its sanitary sewer system, meaning that the surface runoff

will directly enter the receiving water body with minimal treatment and negatively impact the water quality.

As such, efficient source point controls and construction sediment controls are recommended for the project area, while no storm sewer pipe upsizing is required. As discussed in Section 4.3, Silva Cells are proposed to be installed in the road median to provide effective on-site stormwater retention and treatment. An erosion and sediments control plan should be developed and implemented during construction. Some requirements include the following (City of Vancouver, 2017):

- Limit tree and vegetation removal and soil disturbance;
- Catchment basin inlet protection, such as a sediment sack;
- Samples and reports to confirm adherence to Sewer and Watercourse Bylaw No.8093.

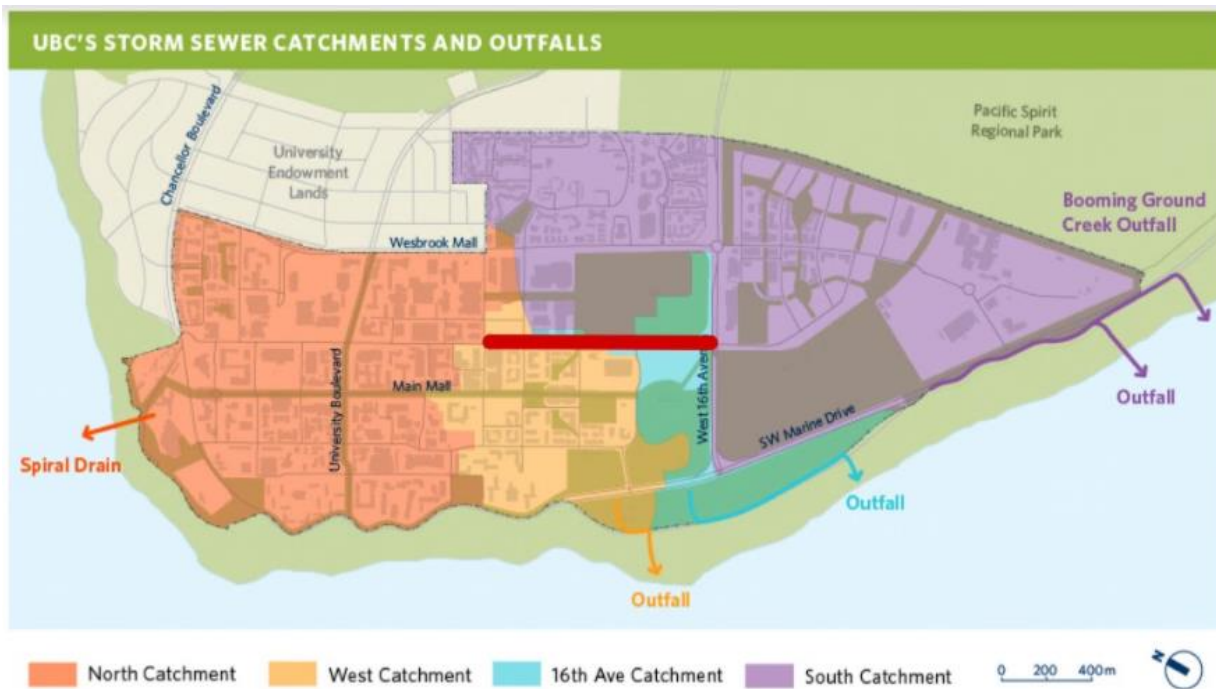

Figure 12: UBC Catchment Areas ([Source](#))

## 7.2 UTILITY MANAGEMENT

As shown in Drawing C12, existing underground utilities in the study area include watermains, storm and sanitary sewers, gas service lines and electrical conduits. This drawing also includes proposed relocation



of existing manholes and catchment basins to avoid conflict with the new road alignment and allow for ease of access for future operation and maintenance. Applicable permits and approvals to construct proximal to existing utilities, as outlined in Section 8.3, will be obtained before the construction begins. In addition, the contractor will be responsible for conducting BC One Call and confirm the location of existing utilities in the field prior to construction. The contractor should also provide up-to-date construction schedules to the contract administrator and utility owners to coordinate required inspection and ensure all the existing utilities will maintain intact during construction.

Electrical conduits will need to be installed for the proposed security poles and flashing crosswalk signals. The design of these conduits should be completed by a professional electrical engineer. The design must be approved by BC Hydro and UBC Energy & Water Use Department.

### **7.3 WASTE MANAGEMENT**

Construction materials, such as metals and electrical equipment, will be carefully planned to allow for recycling and reuse and minimize waste that has to be disposed of at City of Vancouver's designated landfill. Hazardous waste will be identified, handled and disposed of using BC's Hazardous Waste Inventory System and UBC's Hazardous Waste Disposal Guide to prevent contaminants from leaking into soil and water. The construction crew will be trained to deal with hazardous waste and response to spills safely and properly.

### **7.4 NOISE AND AIR POLLUTION CONTROL**

The air quality and emission of contaminant gases will be monitored, controlled and managed in compliance with UBC Air Quality Management Procedures which are based on federal, provincial and Metro Vancouver regulations. Applicable data will be reported to the Environment Canada National Pollutant Release Inventory as per federal requirements. The contractor will spray water onto loose soil and cover stockpiles to reduce dust during construction.

To minimize noise and disruption to nearby residents, the construction is planned for summer when less students will be on campus. The construction hours will be limited to 7:30 am – 7:00 pm on weekdays and 9:00 am – 5:00 pm on weekends in accordance with UBC Noise Bylaw. Construction will not be carried out on holidays.

## **8.0 STAKEHOLDER MANAGEMENT AND PERMITTING**

To ensure the East Mall Redesign project receives the support of the public, stakeholder engagement activities have been carefully planned throughout the design phase of the project. This plan includes identifying key stakeholders, developing a comprehensive engagement plan, and reviewing and responding to the feedback from the numerous stakeholder groups. In addition, required permitting for the road redesign have been identified which directly affects the construction schedule

### **8.1 Key Stakeholders**

The project site and neighbourhood areas have been assessed to identify all stakeholders impacted by the road redesign along East Mall between W16th Avenue and Agronomy Road. Key stakeholders that must be consulted prior to moving forward with the preliminary design have been listed below:

- UBC SEEDS Sustainability Program
- UBC Students, Faculty, Staff
- Ministry of Transportation and Infrastructure (MOTI)
- TransLink
- City of Vancouver
- Musqueam First Nations
- University Endowment Lands
- UBC Thunderbird Residence
- UBC Building Operations
- Technical Enterprise Faculty (Starbucks)
- Eaton Arrowsmith School

- Local residences and businesses along East Mall

## **8.2 Stakeholder Engagement and Consultation Plan**

### **8.2.1 Project Stakeholders**

To communicate with project stakeholders, an online web page for the East Mall Redesign Project will be published entailing general project information, project planning and organizations involved. The web page will showcase the design goals behind the East Mall redesign as well as the preliminary design with the use of videos and photographs. Public feedback will be received through an online survey on the project website. The survey will prompt individuals to specify the stakeholder group they fall under; stakeholder groups includes the general public (students, staff, faculty), members of municipal councils, members of the Ministry of Transportation, Indigenous Groups, local businesses and residences. Once the surveyee has selected their corresponding stakeholder category, the survey will prompt for their e-mails to receive project updates and results from the consultation. For members of municipal councils, opportunities to review the project in more detail will be available upon request.

Once permission is granted for the reconstruction of East Mall, all project details and construction updates will be communicated through the UBC Building Operations website.

### **8.2.2 Local Residences and Businesses**

A public consultation session will be held to showcase the East Mall Redesign and receive feedback from all local landowners and businesses in the neighbourhood. Visual graphics, models and photographs will be shared at the meeting and project team members will be present to answer public inquiries. Social media will be utilized to spread important information regarding road closures and traffic disruptions. The consultation meeting will highlight the importance of safety and environmental sustainability and discuss the matter with all stakeholders. All feedback received from the local residences and businesses will be carefully reviewed by the project team and addressed accordingly. A succinct report of all stakeholder consultation outcomes will be provided.

### 8.2.3 First Nations and Indigenous Groups

A Community Engagement Plan will be established to ensure project initiatives are discussed with the Musqueam First Nations. The plan will support engaging discussions with the First Nations community and provide them with opportunities to voice their opinions and concerns. A formal notification of the East Mall Redesign Project will be issued to the community representatives. Methods to notify the First Nations community will include door-to-door visits, phone calls and e-mails.

A Community Engagement Meeting will be held with the Indigenous Community Chiefs and/or Representatives. At the Community Engagement Meetings, the East Mall Redesign Project will be showcased, and the First Nations will have the opportunity to voice any concerns and suggestions. The project team will address the provided feedback and try to incorporate as much as possible into the project plan; this will ensure the First Nations are satisfied and are supportive of the project. Musqueam First Nations will be notified immediately of any major changes to the project. A community meeting will be arranged as a follow-up to showcase the final project with their ideas and feedback incorporated.

### 8.2.4 Virtual Engagements

In case of a global pandemic, such as COVID-19, social distancing engagements will be encouraged to ensure the safety and wellbeing of all stakeholders. Virtual engagements and consultation meetings will be organized and available to all stakeholders through the project web page. The attendance of all engagements and consultation activities at the location of the event will be limited; only a limited number of attendees will be allowed to be present at the live event. Communication with stakeholders will be done similarly to the methods mentioned in the previous sections, including social media, surveys, mass distributed emails, and the project web page.

## 8.3 Permits

The permitting process will begin immediately after the completion of the detailed design. A total of ten permits has been identified and must be obtained prior to project construction. Table 8 is a non-exhaustive list of the permits required for the construction of the East Mall.

Table 8: List of Required Permitting for the East Mall Redesign Project

Permits	Authority	Description
Development Permit	CoV	Primary permit for development
Building Permit	CoV	Primary permit for development
Archaeology Permit	CoV	Project is located on the traditional, ancestral, and unceded territory of the Musqueam people.
Environmental Permit	CoV	Required when roadways, and trees are involved
Plumbing Permit	CoV	Utility permit for plumbing system under roadway
Sprinkler Permit	CoV	Utility permit for sprinkler system under roadway
Electrical Permit	BC Hydro	Utility permit for installing electrical conduits
Proximal Work Permits		Permit for construction activities proximal to existing underground utilities
Water Mains, Storm, and Sanitary Sewers	UBC Energy & Water Department	Permit for construction activities proximal to existing underground utilities
Gas Lines	Fortis BC	Permit for construction activities proximal to existing underground utilities
Electrical Conduits	BC Hydro	Permit for construction activities proximal to existing underground utilities
WorkSafe BC Permit	WorkSafe BC	Permit to ensure project is safe to proceed
Traffic Permit	CoV	Permit for interrupting traffic during construction

## 9.0 CONSTRUCTION PLANNING

### 9.1 Construction Schedule

Table 9 summarizes the proposed start date and end date of the project. The construction is proposed to be initiated on May 3, 2022, assuming permit application will start on May 3, 2021 (City of Vancouver, 2021). This schedule would allow for more flexibility and time to complete the permitting process and construction planning. The project is expected to finish by October 13, 2022 before the winter season. Refer to Appendix F for a detailed project schedule.

Table 9: Project Construction Key Dates

<b>Project Start Date</b>	May 3rd, 2021
<b>Expected Completion Date</b>	October 13th, 2022

## 9.2 Construction Methodology

The pre-work will begin on May 3rd 2022 after the permit process is completed. The date chosen also avoids the potential of freezing conditions in early spring; which is unsuitable for concrete pouring during road construction. Once the surveying and mobilization process are completed, the construction phase can begin with constructing the Silva Cells.

The core construction phases consist of 3 sections: construction of Silva Cells, North Bound, and South Bound. One section will be completed before the next section begins. This will reserve roadways to reroute existing traffic. The general process of each section's construction involves excavation, construction of the Silva Cells sections and utilities adjustments, followed by backfilling, then complete by median or roadway construction. Finally, the curbs and sidewalks will be refined.

The next phase includes accessories and road signal controls. Additional pedestrian crosswalk signal control poles and lights will be installed. Covered bus stops and UBC Security Poles will be installed along the sidewalk. When the above are completed, the roundabouts and speed-tables can be installed along the roadways.

Once the above core construction is completed, the road finishing processes can begin. The finishing includes the processes of site-clean up for painting of roads and bike lanes. Vegetation at the medium, roundabouts, and sidewalk can be planted. Finally, construction will wrap up after the inspection passes.

The construction of the canopy can begin when the core construction phase completes, starting around July 22, 2022. The canopy components will be prefabricated for quick installation on-site. This will reduce the interruption of the pedestrian in the area. The estimated time of completion is within 2 weeks.

## 10.0 MAINTENANCE

The maintenance of East Mall after the completion of this project has been considered. Components need to be checked regularly to ensure the safety of road users and the functionality of East Mall. Guidelines from the Ministry of Transportation and Infrastructure (MOTI) are used to determine the maintenance requirements and the frequency of maintenance. Table 10 summarizes the corresponding maintenance and inspection criteria for each of the components. The cost of labour, equipment and material for each maintenance task is based on the rates in the City of Vancouver, a detailed breakdown of maintenance cost is in Appendix E.

*Table 10: Maintenance and Inspection for different components*

<b>Components</b>	<b>Maintenance and Inspection</b>
Asphalt Pavement	Should be inspected quarterly and repaired according to the repair chart in “Asphalt Pavement Maintenance” by MOTI.
Drainage	Drainage should be checked as needed, it is recommended to check in Spring and Fall. Should ensure there are no blockages at the catch basins.
Pavement Marking	All longitudinal lines must be repainted annually, other lines should be inspected annually and repaint accordingly.
Sidewalk	Inspection should be done as needed; cracks must be repaired to avoid tripping hazard.
Signage	Signage should be inspected as needed. Visibility of the sign should be examined during inspection.
Silva Cells	Routine inspection is not required, should be inspected as needed. Inspector should check for clogging and condition of the frame, repair must be done if the frame is deteriorated.
Street Cleaning	Street cleaning is required to be done annually in November for leaf clean up.
Streetlight	Maintenance should be done as needed, requires repair when light bulbs are blown out and lamp post connections are loosen.
Traffic Lights	Inspection is recommended every 6 months. Maintenance should be done as needed, requires repair when light is blown out and connections are loosen.
Utilities	Annual inspection is recommended. Utilities should be repaired if there is any leakage or blockage in pipes.
Vegetation	This includes trimming the vegetation on the sidewalks, medians and roundabout. Maintenance should be conducted every 6 months, and should be repaired if it poses any hazard to the road.

## 11.0 RISK MITIGATION OF CONSTRUCTION

The hazards associated with the project and their respect likelihood and impact have been identified. The risk matrix below is used to determine the risk level of the hazards. Table 11 illustrates the risk matrix.

Table 12 lists the identified risks along with recommended mitigation and contingency plans.

*Table 11: Risk matrix*

		Impact →				
		Negligible	Minor	Moderate	Significant	Severe
Likelihood ↑	Very Likely	Low Med	Medium	Med Hi	High	High
	Likely	Low	Low Med	Medium	Med Hi	High
	Possible	Low	Low Med	Medium	Med Hi	Med Hi
	Unlikely	Low	Low Med	Low Med	Medium	Med Hi
	Very Unlikely	Low	Low	Low Med	Medium	Medium



Table 12: Risk register

Risk Description	Likelihood of Risk	Risk Impact	Risk Level	Mitigation Plans	Contingency Plans
Extreme weather that leads to loss of resources and materials	Unlikely	Significant	Medium	<ul style="list-style-type: none"> <li>• Consult with broker/lawyer and obtain appropriate insurance</li> <li>• Ensure emergency response procedures are in place</li> </ul>	<ul style="list-style-type: none"> <li>• Follow WorkSafeBC health and safety procedures</li> <li>• Notify applicable authorities</li> </ul>
Additional design scope (i.e. scope creep) without addressing conflicts in schedule and budget	Unlikely	Significant	Medium	<ul style="list-style-type: none"> <li>• Clearly define project scope in contracts and project agreement</li> </ul>	<ul style="list-style-type: none"> <li>• Document all scope creep, obtain authorization from the project board before accepting and commencing any additional work</li> </ul>
Budget overruns	Possible	Significant	Medium High	<ul style="list-style-type: none"> <li>• Track and forecast costs carefully and include 10% contingency in the budget</li> </ul>	<ul style="list-style-type: none"> <li>• Reduce overhead costs wherever possible</li> <li>• Submit change requests to project board</li> </ul>
Serious accidents and injuries during construction	Very Unlikely	Severe	Medium	<ul style="list-style-type: none"> <li>• Consult with broker/lawyer and obtain appropriate insurance</li> <li>• Train and mandate all staff to follow WorkSafeBC safety regulations</li> <li>• Ensure emergency response procedures are in place</li> </ul>	<ul style="list-style-type: none"> <li>• Follow emergency response procedures</li> <li>• Notify and report incidents to applicable authorities</li> </ul>
Stakeholder dissatisfaction and unresolved conflicts of interest among stakeholders causing delays in permit approval	Unlikely	Significant	Medium	<ul style="list-style-type: none"> <li>• Identify key stakeholders and their influences</li> <li>• Create a Stakeholder Engagement Plan</li> <li>• Document all consultation activities, such as emails</li> </ul>	<ul style="list-style-type: none"> <li>• Follow internal procedures and seek help from mediation professionals</li> <li>• Notify applicable authorities</li> </ul>

**12.0 COST ESTIMATE**

The preliminary cost estimate for the design is summarized in Table 13. The cost includes consulting fees, permitting, project-management, construction and annual maintenance costs. A detailed Class C cost breakdown is included in Appendix E.

*Table 13: Class C Cost Estimate*

	<b>Cost + Disbursement</b>
Consulting Fees	\$414,790
Construction of East Mall	\$3,675,873
Construction of Canopy	\$104,652
Annual Maintenance	\$51,948
<b>Total</b>	<b>\$4,247,263</b>

## 13.0 REFERENCES

BC Ministry of Transportation and Infrastructure. (2013) Construction and Rehabilitation Cost Guide [Online]. Available at: <https://www2.gov.bc.ca/assets/gov/driving-and-transportation/transportation-infrastructure/contracting-with-the-province/documents/costguide-2013.pdf> (Accessed: 16 February 2021)

BC Ministry of Transportation and Infrastructure. (2019) British Columbia Active Transportation Design Guideline [Online]. Available at: [https://www2.gov.bc.ca/assets/gov/driving-and-transportation/funding-engagement-permits/grants-funding/cycling-infrastructure-funding/active-transportation-guide/2019-06-14\\_bcatdg\\_compiled\\_digital.pdf](https://www2.gov.bc.ca/assets/gov/driving-and-transportation/funding-engagement-permits/grants-funding/cycling-infrastructure-funding/active-transportation-guide/2019-06-14_bcatdg_compiled_digital.pdf) (Accessed: 12 September 2020)

Canadian Commission on Building and Fire Code (2019). National building code of Canada. Ottawa, Associate Committee on the National Building Code, National Research Council.

City of Vancouver. (2017) Erosion and Sediment Control Large Lot Development (less than 1,000 m<sup>2</sup>) [Online]. Available at: <https://vancouver.ca/files/cov/2002-002-erosion-and-sediment-control-small-lot-development-less-than-1000m2.pdf> (Accessed: 31 March 2021)

City of Vancouver. (2017) Erosion and Sediment Control Large Lot Development (1,000 m<sup>2</sup> or more) [Online]. Available at: <https://vancouver.ca/files/cov/2002-003-erosion-and-sediment-control-large-lot-development-1000m2-or-more.pdf> (Accessed: 31 March 2021)

City of Vancouver. (2018) Standard Detail Drawings [Online]. Available at: <https://bids.vancouver.ca/bidopp/RFA/Documents/PS20181461-CityofVancouver-StandardDetailDrawingsFirstEdition2018.PDF> (Accessed: 2 February 2021)

City of Vancouver. (2021) Get a Building Permit [Online]. Available at:

<https://vancouver.ca/home-property-development/building-permit.aspx> (Accessed: 9 February 2021)

City of Vancouver. (2021) Report Potholes to Help Keep Roads Safe [Online]. Available at:

<https://vancouver.ca/streets-transportation/pothole-repair.aspx> (Accessed: 16 February 2021)

City of Vancouver. (2021) Sign Code Inventory [Online]. Available at:

<https://vancouver.ca/files/cov/sign-code-inventory.pdf> (Accessed: 6 April 2021)

Deeprout. (2021) Silva Cell Tree and Stormwater Management System [Online]. Available at:

<https://www.deeprout.com/products/silva-cell.html> (Accessed: 31 March 2021)

Government of British Columbia. (2021) Construction and Rehabilitation Cost Guide [Online].

Available at: <https://www2.gov.bc.ca/gov/content/transportation/transportation-infrastructure/contracting-to-transportation/highway-bridge-maintenance/highway-maintenance/contacts> (Accessed: 16 February 2021)

Government of British Columbia. (2021) Highway & Bridge Maintenance [Online]. Available at:

<https://www2.gov.bc.ca/gov/content/transportation/transportation-infrastructure/contracting-to-transportation/highway-bridge-maintenance> (Accessed: 1 March 2021)

J.E.Berkowitz Architectural Glass. (n.d.) Glass Canopies [Online]. Available at:

<https://jeberkowitz.com/glass-canopies> (Accessed: 10 January 2021)

University of British Columbia Risk Management Services. (n.d.). Air Quality [Online]. Available at:

<https://srs.ubc.ca/environment/pollution-prevention/air-quality-2/> (Accessed: 31 March 2021)

University of British Columbia Risk Management Services. (n.d.). Noise Control Bylaw. Available at:

[http://bog2.sites.olt.ubc.ca/files/2012/09/3.2\\_2012.09\\_UNA-Bylaws1.pdf](http://bog2.sites.olt.ubc.ca/files/2012/09/3.2_2012.09_UNA-Bylaws1.pdf) (Accessed: 31 March 2021)

University of British Columbia Risk Management Services. (n.d.). Hazardous Waste Disposal Guide. Available at: <https://srs.ubc.ca/environment/hazardous-waste-management/hazardous-waste-disposal-guide/> (Accessed: 31 March 2021)

University of British Columbia Risk Management Services. (n.d.). Spills & Contaminated Sites. Available at: <https://srs.ubc.ca/environment/pollution-prevention/spills-and-contaminated-sites-2/> (Accessed: 31 March 2021)

University of British Vancouver Campus. (2017). Integrated Stormwater Management Plan [Online]. Available at: [https://planning.ubc.ca/sites/default/files/2019-11/PLAN\\_UBC\\_ISMP\\_Final2017.pdf](https://planning.ubc.ca/sites/default/files/2019-11/PLAN_UBC_ISMP_Final2017.pdf) (Accessed: 31 March 2021)

University of British Columbia Wayfinding. (n.d.). Exterior Signage Standards and Guidelines. Available at: [http://assets.brand.ubc.ca/downloads/ubc\\_%20signage\\_standards\\_and\\_guidelines\\_2019.pdf](http://assets.brand.ubc.ca/downloads/ubc_%20signage_standards_and_guidelines_2019.pdf) (Accessed: 31 March 2021)

Metro Performance Glass. (n.d.) Catalogue & Reference Guide 6th Edition Structural Glass Canopies [Online]. Available at: <https://www.metroglass.co.nz/catalogue/141.aspx> (Accessed: 10 January 2021)

NORR Architects, Engineers, Planners. (2017) General Notes [Online]. Available at: [https://buyandsell.gc.ca/cds/public/2017/10/23/201bdd271f3a1e82451159475031f5c5/2017-03-17\\_ncca15-0144\\_stru\\_ifit\\_3\\_1.pdf](https://buyandsell.gc.ca/cds/public/2017/10/23/201bdd271f3a1e82451159475031f5c5/2017-03-17_ncca15-0144_stru_ifit_3_1.pdf) (Accessed: 2 February 2021)

RONSTAN Tensile Architecture. (2021) Tensile Structure Steel Cable ACS1 [Online]. Available at: <https://www.archiexpo.com/prod/ronstan/product-5804-164076.html> (Accessed: 10 January 2021)

Sichello, B. (2019) 2019 Construction Cost – BC Interior [Online]. Available at: <https://www.nido.design/post/2019-construction-costs-bc-interior> (Accessed: 16 February 2021)

UBC Technical Guidelines. (n.d.) Building, Structural & Snow Load Design [Online]. Available at: [http://www.technicalguidelines.ubc.ca/technical/structural\\_design\\_snow\\_loads.html#a](http://www.technicalguidelines.ubc.ca/technical/structural_design_snow_loads.html#a) (Accessed: 14 February 2021)

Deeprout. Silva Cell Operation and Maintenance Manual. Available at: [www.deeprout.com/silvapdfs/resources/construction/Silva-Cell-Operations-and-Maintenance-Manual.pdf](http://www.deeprout.com/silvapdfs/resources/construction/Silva-Cell-Operations-and-Maintenance-Manual.pdf). (Accessed: 31 March 2021)

Ministry of Transportation and Infrastructure. (April 2016) Asphalt Pavement Maintenance. Available at: <https://www2.gov.bc.ca/assets/gov/driving-and-transportation/transportation-infrastructure/highway-bridge-maintenance/pavement-marking/asphaltpavementmaintenance.pdf> (Accessed: 31 March 2021)

Ministry of Transportation and Infrastructure. (2019) Highway Maintenance Quality Plan and Contractor Assessment Program Manual. Available at: [https://www2.gov.bc.ca/assets/gov/driving-and-transportation/transportation-infrastructure/highway-bridge-maintenance/highway-maintenance/round\\_6\\_cap\\_manual\\_v3-6\\_february\\_2020.pdf](https://www2.gov.bc.ca/assets/gov/driving-and-transportation/transportation-infrastructure/highway-bridge-maintenance/highway-maintenance/round_6_cap_manual_v3-6_february_2020.pdf) (Accessed: 31 March 2021)

## **Appendix A: Detailed Design Drawings**

**GENERAL NOTES:**

1. READ STRUCTURAL DRAWINGS IN CONJUNCTION WITH SEPARATELY BOUND SPECIFICATIONS, TYPICAL DETAILS AND ALL OTHER CONTRACT DOCUMENTS. DRAWINGS AND SPECIFICATIONS ARE COMPLEMENTARY DOCUMENTS.
2. WHERE DOCUMENTS ARE REFERENCED IN THE GENERAL AND DESIGN NOTES, THEY SHALL BE THE LATEST EDITIONS, UNLESS OTHERWISE NOTED OR SHOWN.
3. THE CONTRACTOR SHALL KEEP WORK SITES CLEAN AND FREE OF ALL CONSTRUCTION DEBRIS DURING THE PROCESS OF CONSTRUCTION AND LEAVE THE SITE CLEAN UPON COMPLETION OF WORK OR PORTIONS OF THE WORK.
4. CHECK AND VERIFY IN THE FIELD ALL SIZES AND DIMENSIONS INVOLVING THE EXISTING STRUCTURE AND COORDINATE WITH NEW CONSTRUCTION. MAKE ADJUSTMENTS TO SUIT EXISTING CONDITIONS.
5. DO NOT EXCEED DURING CONSTRUCTION. DESIGN LIVE LOADS SHOWN ON PLANS, REDUCED AS NECESSARY UNTIL MATERIALS REACH DESIGN STRENGTH.
6. DIMENSIONS ARE IN MILLIMETRES UNLESS NOTED OTHERWISE. ELEVATIONS ARE IN METRES UNLESS NOTED OTHERWISE.
7. SCALES NOTED ON DRAWINGS ARE FOR GENERAL INFORMATION ONLY. DO NOT SCALE DRAWINGS.
8. CONSULTANT MUST APPROVE ALL DEVIATIONS FROM THE WORKING DRAWINGS. THE CONTRACTOR MUST KEEP AN ACCURATE RECORD OF ALL CHANGES FROM THE ORIGINAL INFORMATION SHOWN ON THE CONSTRUCTION DRAWINGS.
9. FEATURES OF CONSTRUCTION NOT FULLY SHOWN ARE OF THE SAME CHARACTER AS THOSE NOTED FOR SIMILAR CONDITIONS.
10. IF DISCREPANCIES EXIST BETWEEN THESE DRAWINGS AND SPECIFICATIONS, CONTACT ENGINEER FOR REVIEW AND APPROVAL PRIOR TO PROCEEDING.
11. DRAWINGS AND DETAILS ARE INTENDED TO SHOW THE END RESULT OF DESIGN. MODIFICATIONS TO THE DESIGN NECESSARY TO SUIT MEANS AND METHODS OF CONSTRUCTION, SITE DIMENSIONS OR CONDITIONS SHALL BE SUBMITTED TO CONSULTANT FOR APPROVAL BEFORE PROCEEDING.
12. THE CONTRACTOR FOR ANY PORTION OF WORK SHALL VISIT THE SITE AND SHALL BE THOROUGHLY FAMILIAR WITH ALL PHYSICAL FEATURES THAT MAY AFFECT THE WORK IN ANY WAY.
13. ALL CONSTRUCTION SHALL CONFORM TO THE LATEST EDITION OF THE FOLLOWING:  
OCCUPATIONAL HEALTH AND SAFETY ACT  
WORK SAFE BC – OHS REGULATION PART 20  
WORKERS COMPENSATION ACT

**GENERAL MATERIALS:**

1. DELIVER MATERIALS TO THE JOB SITE IN DRY CONDITION. KEEP MATERIALS DRY AND CLEAN UNTIL USE.
2. BACKFILL WITH 20MM GRANULAR ROAD BASE UNLESS OTHERWISE NOTED ON THE DRAWINGS. COMPACT IN 30CM LIFTS TO A MINIMUM OF 98% S.P.D. AND WITHIN ± 2% OF THE OPTIMUM MOISTURE CONTENT.
3. ALL CEMENT TO BE PORTLAND BLAST FURNACE SLAG CEMENT TO CSA A23.1 CLAUSE 4.2.1.
4. ALL REINFORCING STEEL TO BE GRADE 400 DEFORMED BARS TO CSA G30.18.
5. DISPOSAL OF ALL EXCAVATED MATERIAL SHALL BE OFF-SITE OTHER THAN APPROVED BACKFILL.
6. BACKFILL MATERIAL SHALL BE STORED ON SITE IN A WAY TO PROTECT IT FROM PRECIPITATION IF NECESSARY.

**CONSTRUCTION:**

1. THE CONTRACTOR SHALL PROPOSE A FULL METHODOLOGY FOR EXECUTING THE WORK DETAILED IN THE CONTRACT DOCUMENTS.
2. UNLESS SPECIFICALLY NOTED OTHERWISE ON THE DRAWINGS, NO PROVISIONS HAVE BEEN MADE IN THE DESIGN FOR CONDITIONS OCCURRING DURING CONSTRUCTION.
  - a. THE CONTRACTOR SHALL DEMONSTRATE THE STABILITY AND SAFETY OF ALL ELEMENTS OF THE BUILDING DURING EVERY STAGE OF CONSTRUCTION.
  - b. THE CONTRACTOR SHALL PROVIDE ALL NECESSARY BRACING AND SHORING REQUIRED FOR ALL STRESSES AND INSTABILITY OCCURRING DURING CONSTRUCTION. THE CONTRACTOR SHALL ACCEPT FULL RESPONSIBILITY FOR ALL SUCH MEASURES.
  - c. THE CONTRACTOR SHALL PROVIDE ALL NECESSARY BRACING, SHORING, SHEET PILING OR OTHER TEMPORARY SUPPORTS TO SAFEGUARD ALL EXISTING OR ADJACENCY AFFECTED BY THIS WORK.
  - d. THE CONTRACTOR SHALL PROVIDE ALL NECESSARY BRACING, SHORING, SHEET PILING OR OTHER TEMPORARY SUPPORTS TO SAFEGUARD ALL EXISTING OR ADJACENCY AFFECTED BY THIS WORK.
3. THE CONTRACTOR SHALL LIAISE WITH OWNER AND ASSOCIATED UTILITIES AUTHORITIES REGARDING THE REMOVAL AND DISCONNECTION OF EXISTING UTILITIES IN THE BUILDING. NO UTILITIES SHALL BE REMOVED OR DISCONNECTED WITHOUT THE APPROVAL OF OWNER AND ASSOCIATED UTILITIES AUTHORITIES.
4. THE CONTRACTOR SHALL BE RESPONSIBLE FOR ALL SAFETY PRECAUTIONS AND THE METHODS, TECHNIQUES, SEQUENCES OR PROCEDURES REQUIRED TO PERFORM THE WORK. THE CONSULTANT HAS NO OVERALL SUPERVISION AUTHORITY AND/OR DIRECT RESPONSIBILITY FOR THE SPECIFIC WORKING CONDITIONS AT THE SITE AND/OR FOR ANY HAZARDS RESULTING FROM ACTIONS OF ANY TRADE CONTRACTOR. THE CONSULTANT HAS NO DUTY TO INSPECT, SUPERVISE, NOTE, CORRECT OR REPORT ANY HEALTH OR SAFETY DEFICIENCIES OF THE OWNER, CONTRACTORS, OR OTHER ENTITIES OR PERSONS ON THE PROJECT SITE.
5. THE CONTRACTOR SHALL DETERMINE THE LOCATIONS OF ALL ADJACENT UNDERGROUND UTILITIES PRIOR TO EARTHWORK, FOUNDATIONS SHORING AND EXCAVATION. ANY UTILITY INFORMATION SHOWN ON THE DRAWINGS AND DETAILS IS APPROXIMATE AND NOT NECESSARILY COMPLETE.
6. THE PROPOSED SCHEDULE OF WORK IS TO BE COORDINATED WITH ALL SUB-TRADES, THE CONSULTANT AND OWNER.
7. INSPECT THE EXISTING CONSTRUCTION AND BECOME THOROUGHLY FAMILIAR WITH THE EXISTING PHASES.

**CONCRETE FORMWORK:**

1. THE DESIGN AND FIELD REVIEW OF FORMWORK IS THE RESPONSIBILITY OF THE CONTRACTOR.
2. NO SIDEWALK FORMS SHALL BE REMOVED BEFORE THE CONCRETE HAS REACHED A MINIMUM OF 8 MPA.

**SHOP DRAWINGS:**

1. FOR ALL STRUCTURAL COMPONENTS SHOWN ON THE STRUCTURAL DRAWINGS, SUBMIT COPIES OF SHOP DRAWINGS AS DIRECTED, FOR REVIEW BY THE CONSULTANT.
2. SHOP DRAWINGS SHALL SHOW COMPLETE INFORMATION FOR THE FABRICATION AND ERECTION OF THE STRUCTURAL COMPONENTS.
3. REVIEW BY THE CONSULTANT SHALL NOT RELIEVE THE CONTRACTOR OF THE RESPONSIBILITY FOR SEEING THAT THE WORK IS COMPLETE, ACCURATE AND IN CONFORMITY WITH ALL CONTRACT DRAWINGS, AND SPECIFICATIONS.
4. SHOP DRAWINGS FOR STRUCTURAL COMPONENTS DESIGNED BY THE FABRICATOR/CONTRACTOR'S ENGINEER MUST BE SEALED, SIGNED AND DATED BY A PROFESSIONAL ENGINEER LICENSED TO PRACTICE IN THE PROVINCE OF BRITISH COLUMBIA. DRAWINGS.

**SOILS, BACKFILLING, AND COMPACTION:**

1. THE CONTRACTOR SHALL RETAIN A GEOTECHNICAL ENGINEER LICENSED TO PRACTICE IN THE PROVINCE OF BRITISH COLUMBIA.
2. THE GEOTECHNICAL ENGINEER RETAINED BY THE CONTRACTOR SHALL INSPECT THE CONDITION AND ASSURE THE ADEQUACY OF ALL SUB-GRADES, FILLS, AND BACKFILLS BEFORE PLACEMENT OF PILES, FOUNDATIONS, FOOTINGS, SLABS AND WALLS. AT THE COMPLETION OF THE PROJECT, THE GEOTECHNICAL ENGINEER SHALL ISSUE AN AUTHENTICATED LETTER OF ASSURANCE STATING THAT ALL FOOTINGS/PILES HAVE BEEN INSTALLED AND MEET THE REQUIREMENTS OF THE CONTRACT DOCUMENTS.
3. BACKFILL MATERIAL SHALL CONSIST OF CLEAN, WELL GRADED GRANULAR SOILS FREE OF ORGANIC MATERIAL, SILT AND CLAY AS SPECIFIED IN THE EARTH WORKS SPECIFICATION SECTION.
4. BACKFILLING SHALL BE CARRIED OUT IN A MAXIMUM LIFTS OF 200 mm OF LOOSE FILL, EACH COMPACTED THE STANDARD PROCTOR MAXIMUM DRY DENSITY INDICATED IN THE SPECIFICATIONS.
5. DO NOT PLACE BACKFILL AGAINST WALLS RETAINING EARTH (OTHER THAN CANTILEVER WALLS) UNTIL THE WALLS AND THE FLOOR CONSTRUCTIONS AT TOP AND BOTTOM OF THE WALLS HAVE BEEN CAST AND ATTAINED THEIR DESIGN STRENGTH.
6. WHERE BACKFILL IS PLACED ON EACH SIDE OF FOUNDATION WALLS, DO NOT EXCEED A GRADE DIFFERENCE OF 600 mm.
7. WHERE THE SLAB ON GRADE IS USED TO TIE THE TOP OF A WALL RETAINING EARTH, THAT WALL SHALL BE ADEQUATELY SHORED UNTIL THE SLAB HAS BEEN CAST AND ATTAINED ITS DESIGN STRENGTH.
8. USE LIGHT, HAND-OPERATED COMPACTING EQUIPMENT TO COMPACT BACKFILL ADJACENT TO FOUNDATION WALLS OR RETAINING WALLS.
9. EXCAVATED MATERIAL SHALL BE LEGALLY DISPOSED OF, STORED AT THE SITE, OR USED FOR BACKFILLING OPERATIONS AS REQUIRED IN ACCORDANCE WITH THE GEOTECHNICAL ENGINEERS RECOMMENDATIONS AND PROJECT SPECIFICATIONS.
10. IT IS THE RESPONSIBILITY OF CONTRACTOR TO VERIFY THE GEOTECHNICAL INFORMATION AND TO OBTAIN HIS OWN DATA AND TO POINT DISCREPANCIES TO THE CONSULTANT WHERE THEY OCCUR.

**CAST IN PLACE CONCRETE:**

1. ALL CONCRETE SHALL CONFORM TO CSA STANDARD A23.1 (LATEST EDITION) HAVING A MINIMUM COMPRESSIVE STRENGTH OF 32 MPA (UNLESS NOTED OTHERWISE).
2. SUBMIT CONCRETE MIX DESIGN TO ENGINEER PRIOR TO PRODUCTION.
3. NO WATER SHALL BE ADDED TO THE CONCRETE AT THE SITE.
4. SUBMIT PLACING DRAWINGS AND BAR LISTS FOR ALL REINFORCING STEEL TO RIS0 MANUAL SUFFICIENTLY DETAILED AND DIMENSIONED TO PERMIT PLACING OF ALL REINFORCING WITHOUT REFERENCE TO DESIGN DRAWINGS.
5. THE OWNER WILL EMPLOY A TESTING COMPANY TO CONDUCT STRENGTH, SLUMP, MATERIAL AND AIR ENTRAINMENT TESTS ONCE FOR EVERY DAY CONCRETE IS POURED, OR EVERY 50M3 IF THE POUR FOR THAT DAY EXCEEDS 50M3.
6. ALL CONCRETE SHALL HAVE A 5 TO 7% AIR ENTRAINMENT AT TIME OF PLACING.
7. BULL FLOAT CONCRETE SURFACES AND PROVIDE A LIGHT TROWEL FINISH TO PRODUCE A SMOOTH NON-SLIP SURFACE FREE FROM RIDGES, VOIDS AND MACHINE MARKS.
8. KEEP CONTINUOUSLY MOIST ALL EXPOSED NON-FORMED SURFACES FOR A MINIMUM OF SEVEN CONSECUTIVE DAYS AFTER PLACEMENT OF CONCRETE.
9. WHERE NEW CONCRETE IS TO BE PLACED AGAINST EXISTING CONCRETE, THE EXISTING CONCRETE MUST BE THOROUGHLY CLEANED TO REMOVE OIL, GREASE AND DIRT AND BE SURFACE CHIPPED A MINIMUM OF ONE-HALF INCH PRIOR TO PLACEMENT OF NEW CONCRETE. APPLICATION OF AN APPROVED BONDING AGENT SHALL BE APPLIED TO ALL INTERFACES BETWEEN NEW AND OLD CONCRETE.
10. PROVIDE HOT OR COLD WEATHER PROTECTION WHEN EXTERIOR TEMPERATURES FALL OUTSIDE OF THE CURING TEMPERATURE RANGE AS SPECIFIED IN CSA A23.1.
11. VIBRATE ALL CONCRETE. ENSURE ALL CONCRETE IS DENSE, FREE OF HONEYCOMBING, AND THAT NO SEGREGATION OCCURS.
12. ENSURE ALL INSTALLED REBAR IS CLEAN AND SECURELY HELD IN THE CORRECT LOCATION, AS PER SHOP DRAWINGS, DURING PLACING.

**REINFORCING STEEL:**

1. LAP ALL REINFORCING AS PER RIS0 MANUAL, CLASS "B" TENSION LAP.
2. INTERSECTING REGBAR SHALL BE TIED TOGETHER USING NO.16 U.S. WIRE GAUGE OR HEAVIER ANNEALED WIRE OR AN APPROVED PATENTED TYING SYSTEM.
3. ADEQUATELY SUPPORT REINFORCEMENT WITH SPACERS OR CONCRETE BRICKS TO SECURE AGAINST DISPLACEMENT WITHIN THE TOLERANCE INDICATED IN THE LATEST EDITION OF CSA A23.1.
4. NOTIFY THE CONSULTANT FOR SITE REVIEW OF REINFORCEMENT 48 HOURS PRIOR TO THE PLACEMENT OF CONCRETE.
5. MINIMUM COVER TO REINFORCEMENT SHALL BE 3" FOR CONCRETE CAST AGAINST SOIL UNLESS NOTED OTHERWISE.

**ASPHALT:**

1. THE SELECTION, APPLICATION AND APPROVAL OF THE ASPHALT MIX IS AT THE DISCRETION OF THE ENGINEER. PAVEMENT DEFLECTIONS SHALL BE MEASURED WITH A BENKELMAN BEAM OR A FALLING WEIGHT DEFLECTOMETER. MAXIMUM DEFLECTIONS ARE FOR ACCEPTABILITY IS 1.0.
2. VIBRATORY ROLLERS MAY ONLY BE USED WITH PRECAUTION TO ENSURE THERE WILL BE NO DAMAGE DONE TO NEARBY STRUCTURES AND UTILITIES, OR CAUSE UNREASONABLE DISCOMFORT TO NEARBY RESIDENTS. IF NECESSARY, VIBRATION MONITORING WILL BE THE RESPONSIBILITY OF THE CONTRACTOR.
3. THE GRADE AND CAMBER SHALL BE SMOOTH AND TRUE, AND CONFORM TO THE GRADE AND CAMBER OF THE EXISTING SURFACE, WHERE APPLICABLE.
4. ASPHALT SHALL BE PAVED IN TWO UNIFORM LIFTS EACH 75MM THICK, WITHOUT SEGREGATION.
5. ALL EXCESS ASPHALT SHALL BE REMOVED BY SWEEPING.
6. PROVIDE THE BEST POSSIBLE SEAMLESS JOINTS BE RAKING OF FINER MATERIALS TO FILL IN ALL THE GAPS BETWEEN OLD AND NEW ASPHALT. THE TRANSITION BETWEEN MUST BE MADE FLUSH.
7. SMALLER APPROVED POWER COMPACTORS OR TAMPERS SHALL BE USED IN AREAS AROUND MAINTENANCE HOLES, POLES, OR OTHER STRUCTURES WHICH ARE INACCESSIBLE TO A ROLLER.

DRAWING LIST	
SHEET NUMBER	DRAWING NAME
G-01	GENERAL NOTES
C-01	ROAD ALIGNMENT (EXISTING AND PROPOSED)
C-02	TYPICAL CROSS SECTION 1
C-03	TYPICAL CROSS SECTION 2
C-04	AGRONOMY RD BLOCK
C-05	AGRONOMY RD BLOCK INTERSECTION
C-06	THUNDERBIRD BLVD BLOCK
C-07	THUNDERBIRD BLVD BLOCK INTERSECTION
C-08	EAGLES DR BLOCK
C-09	EAGLES DR BLOCK INTERSECTION
C-10	STADIUM RD BLOCK
C-11	STADIUM RD BLOCK INTERSECTION
C-12	EAST MALL UTILITIES
C-13	STANDARD DETAILS
C-14	ROAD SIGNS
S-01	CANOPY

DATE	ISSUED FOR	REV
2021-01-31	50% PROGRESS	A
2021-02-14	70% PROGRESS	B
2021-04-12	CONSTRUCTION	C

This drawing has been prepared solely for the use of the CLIENT and there are no representations of any kind made by NORR Architects Engineers Planners to any party with whom NORR Architects Engineers Planners has not entered into a contract.

This drawing shall not be used for construction purposes until the seal appearing hereon is signed and dated by the Architect or Engineer.

Consultants	TEAM 16
Civil	TEAM 16
Landscape	TEAM 16
Architectural	TEAM 16
Structural	TEAM 16

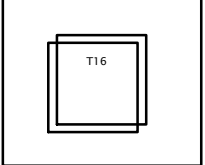
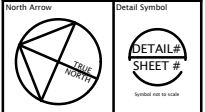

Approval Stamps	

Drawn	GRACE WANG
Checked	GRACE WANG
Client	UBC SEEDS
Project	EAST MALL REDESIGN
Drawing Title	GENERAL NOTES
Scale	1:3
Project No.	Project #2
Drawing No.	G-01



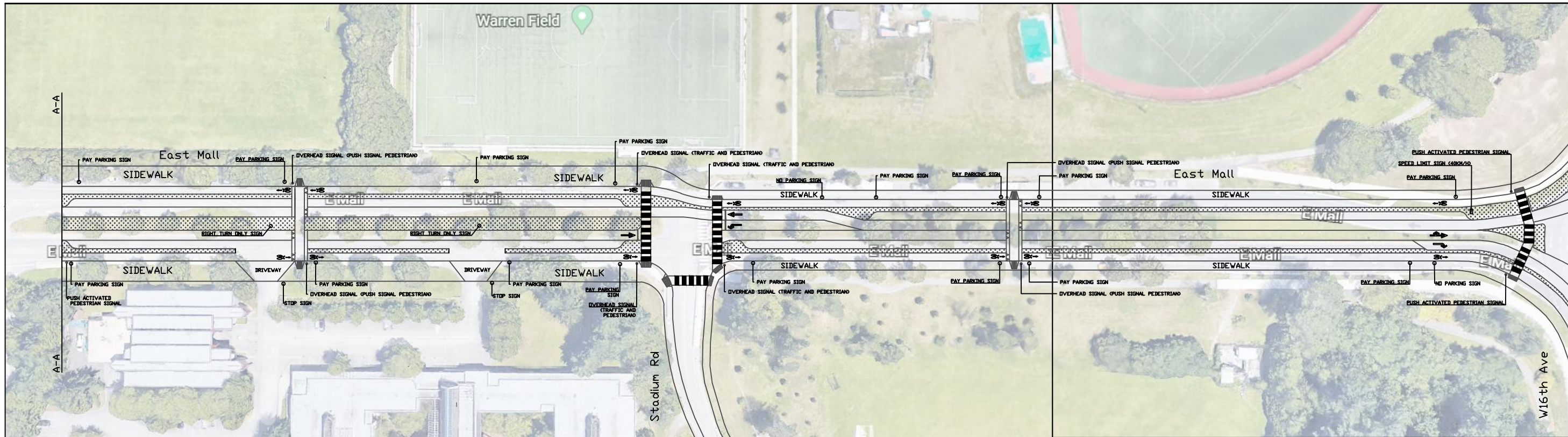
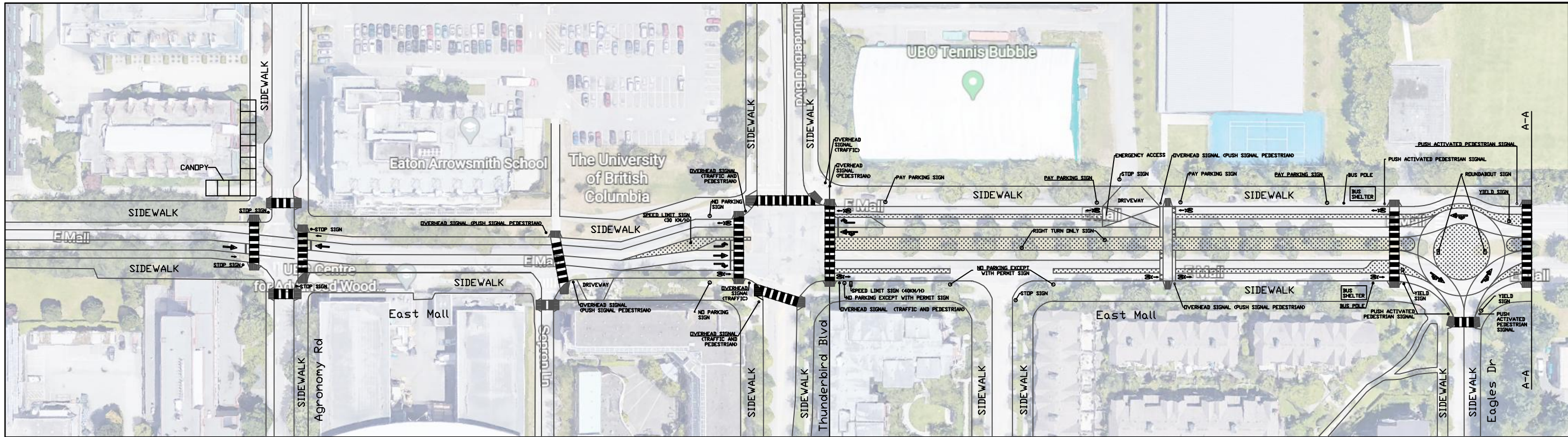

DATE	ISSUED FOR	REV
2021-02-19	10% PROGRESS	A
2021-03-03	30% PROGRESS	B
2021-03-31	FOR CONSTRUCTION	C

This drawing has been prepared solely for the use of the CLIENT and there are no representations of any kind made by Team 16 Architects Engineers Planners to any party with who Team 16 Architects Engineers Planners has not entered into a contract.

This drawing shall not be used for construction purposes until the seal appearing hereon is signed and dated by the Architect or Engineer.

Consultants  
 Civil: TEAM 16  
 Landscape: TEAM 16  
 Architectural: TEAM 16  
 Structural: TEAM 16

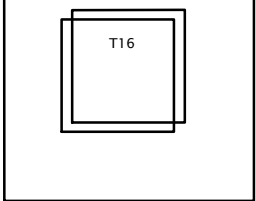
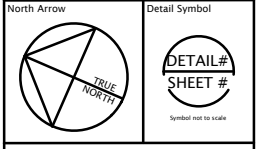

Approval Stamps

Drawn	LILIAN VUONG
Checked	FIONA ZHANG
Client	UBC SEEDS
Project	EAST MALL REDESIGN
Drawing Title	EAST MALL ALIGNMENT
Scale	1:33
Project No.	Project #2
Drawing No.	C-01

DATE	ISSUED FOR	REV
2020-12-03	50% PROGRESS	A
2021-03-05	90% PROGRESS	B
2021-04-12	ISSUED FOR CONSTRUCTION	C

This drawing has been prepared solely for the use of the CLIENT and there are no representations of any kind made by Team 16 Architects Engineers Planners to any party with who Team 16 Architects Engineers Planners has not entered into a contract. This drawing shall not be used for construction purposes until the seal appearing hereon is signed and dated by the Architect or Engineer.

Consultants  
 Civil: TEAM 16  
 Landscape: TEAM 16  
 Architectural: TEAM 16  
 Structural: TEAM 16

North Arrow	Detail Symbol
Symbol not to scale	

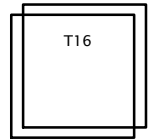

Approval Stamps

Drawn: FIONA ZHANG  
 Checked: FIONA ZHANG  
 Client: UBC SEEDS  
 Project: EAST MALL REDESIGN  
 Drawing Title: TYPICAL CROSS SECTION - 1  
 Scale: N.T.S.  
 Project No.: Project #2  
 Drawing No.: C-02

- TYPICAL ROAD STRUCTURE**
- ① CONCRETE SIDEWALK
  - ② TOP SOIL & SOD
  - ③ BARRIER CURB c/w GUTTER
  - ④ APPROVED SUPERPAVE
  - ⑤ SILVA CELL SYSTEM (SEE DRAWING 1.3)

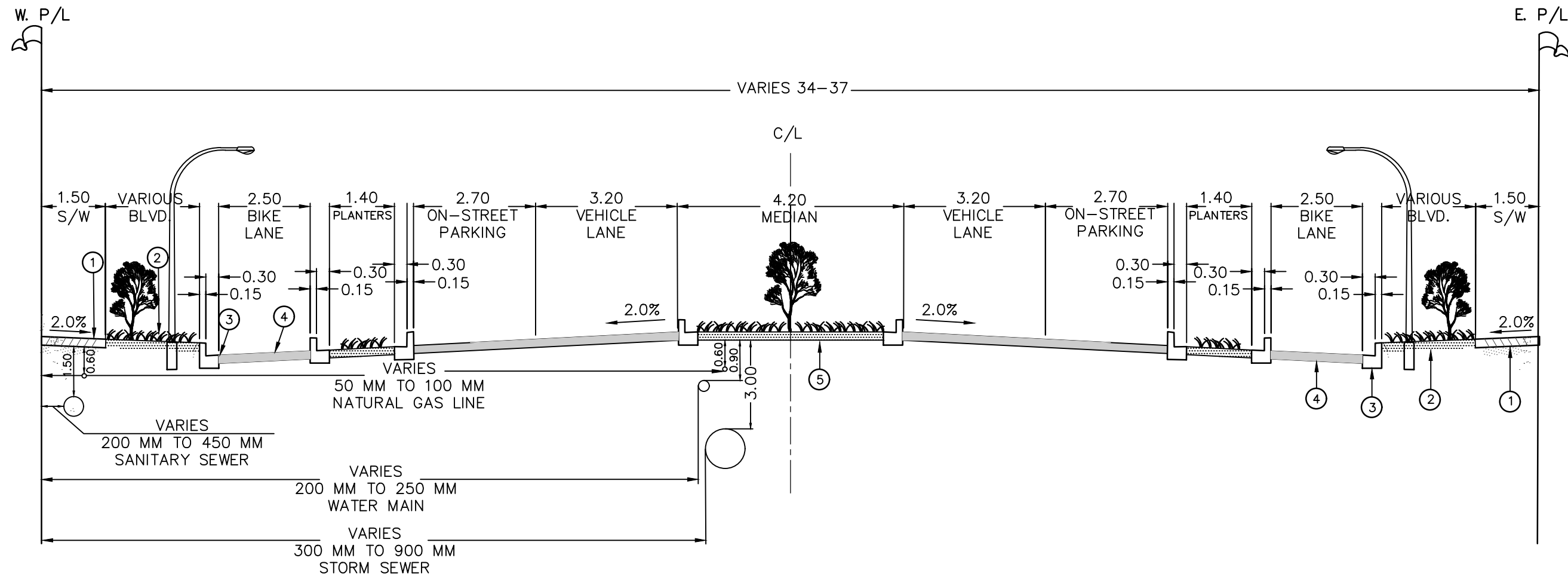

TYPICAL SECTION THUNDERBIRD BLVD., EAGLES DR.  
 N.T.S.

DATE	ISSUED FOR	REV
2020-12-03	50% PROGRESS	A
2021-03-05	90% PROGRESS	B
2021-04-12	ISSUED FOR CONSTRUCTION	C

This drawing has been prepared solely for the use of the CLIENT and there are no representations of any kind made by Team 16 Architects Engineers Planners to any party with who Team 16 Architects Engineers Planners has not entered into a contract. This drawing shall not be used for construction purposes until the seal appearing hereon is signed and dated by the Architect or Engineer.

Consultants  
 Civil: TEAM 16  
 Landscape: TEAM 16  
 Architectural: TEAM 16  
 Structural: TEAM 16

North Arrow

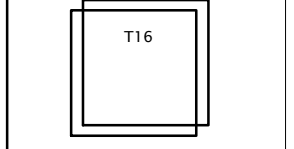

Approval Stamps

Drawn  
FIONA ZHANG  
 Checked  
FIONA ZHANG  
 Client  
UBC SEEDS  
 Project  
EAST MALL REDESIGN  
 Drawing Title  
TYPICAL CROSS SECTION - 2  
 Scale  
N.T.S  
 Project No. Project #2  
 Drawing No. C-03

TYPICAL ROAD STRUCTURE

- ① CONCRETE SIDEWALK
- ② TOP SOIL & SOD
- ③ BARRIER CURB c/w GUTTER
- ④ APPROVED SUPERPAVE

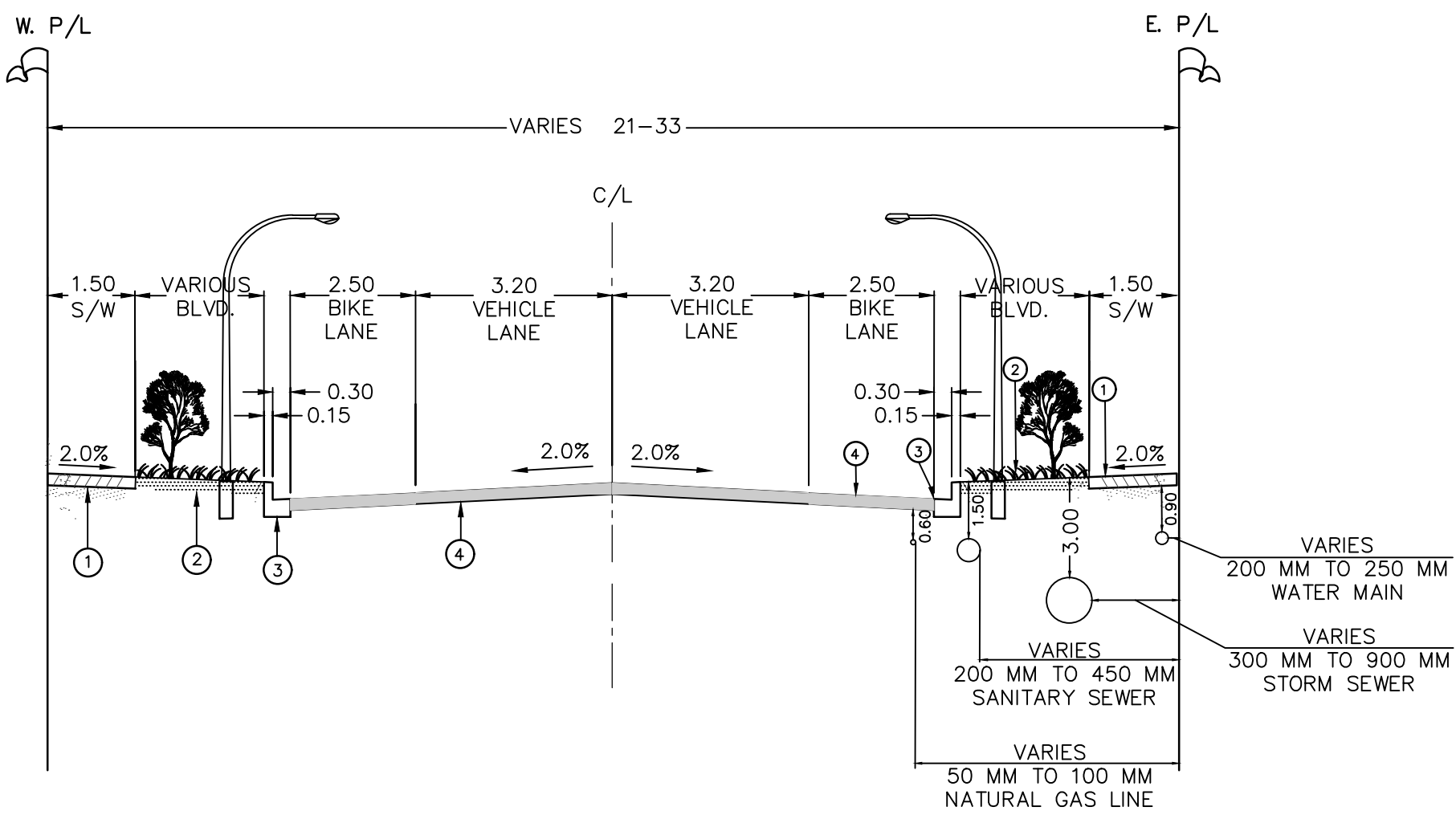

TYPICAL SECTION AGRONOMY RD., STADIUM RD.  
N.T.S.

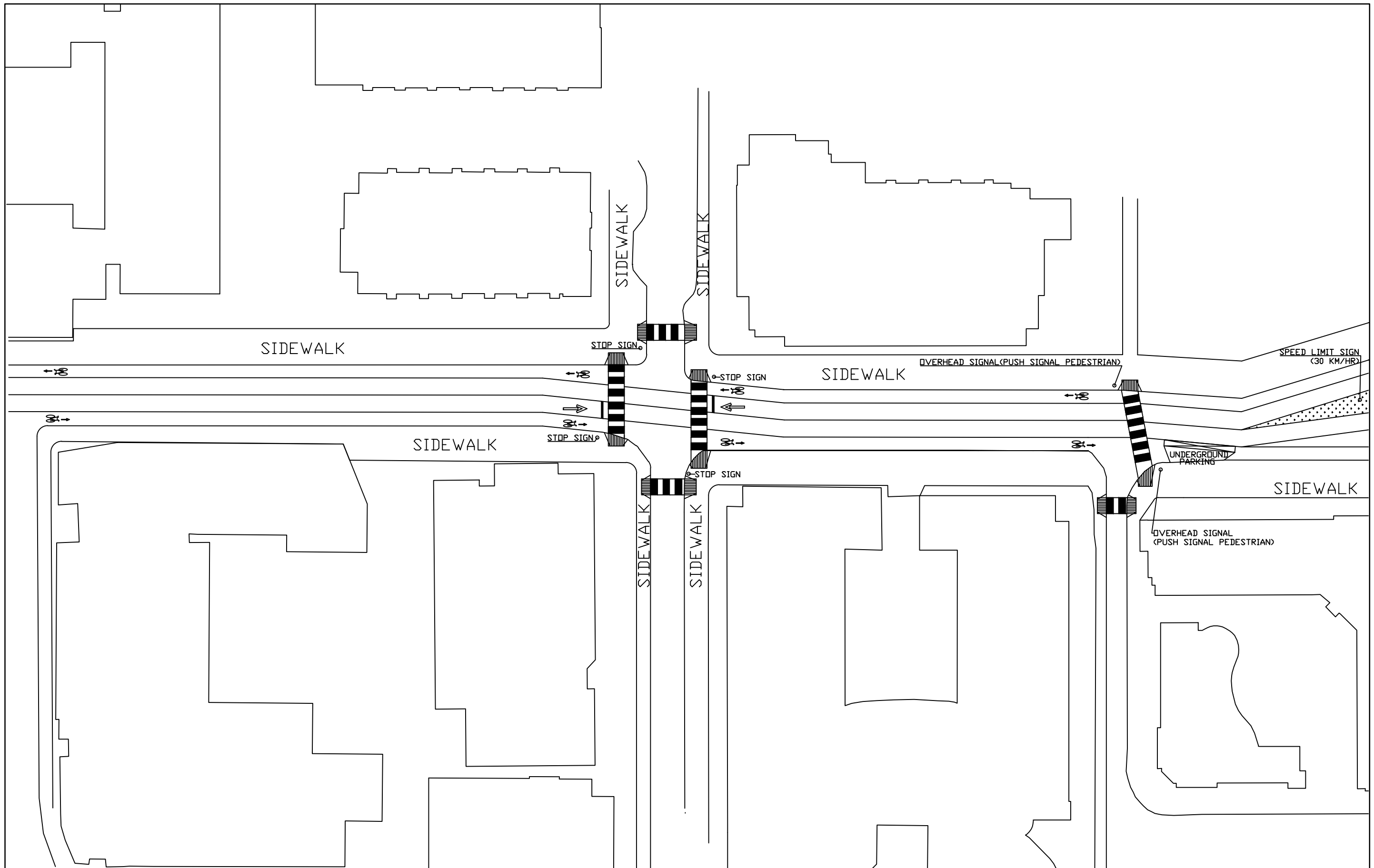

DATE	ISSUED FOR	REV
2021-02-07	50% PROGRESS	A
2021-02-28	90% PROGRESS	B
2021-04-12	CONSTRUCTION	C

This drawing has been prepared solely for the use of the CLIENT and there are no representations of any kind made by Team 16 Architects Engineers Planners to any party with who Team 16 Architects Engineers Planners has not entered into a contract.

This drawing shall not be used for construction purposes until the seal appearing hereon is signed and dated by the Architect or Engineer.

Consultants  
 Civil: TEAM 16  
 Landscape: TEAM 16  
 Architectural: TEAM 16  
 Structural: TEAM 16

North Arrow

Detail Symbol

Symbol not to scale

T16

Approval Stamps

Drawn  
GRACE WANG

Checked  
GRACE WANG

Client  
UBC SEEDS

Project  
EAST MALL REDESIGN

Drawing Title  
AGRONOMY RD  
BLOCK

Scale  
1:20

Project No. Project #2

Drawing No. C-04

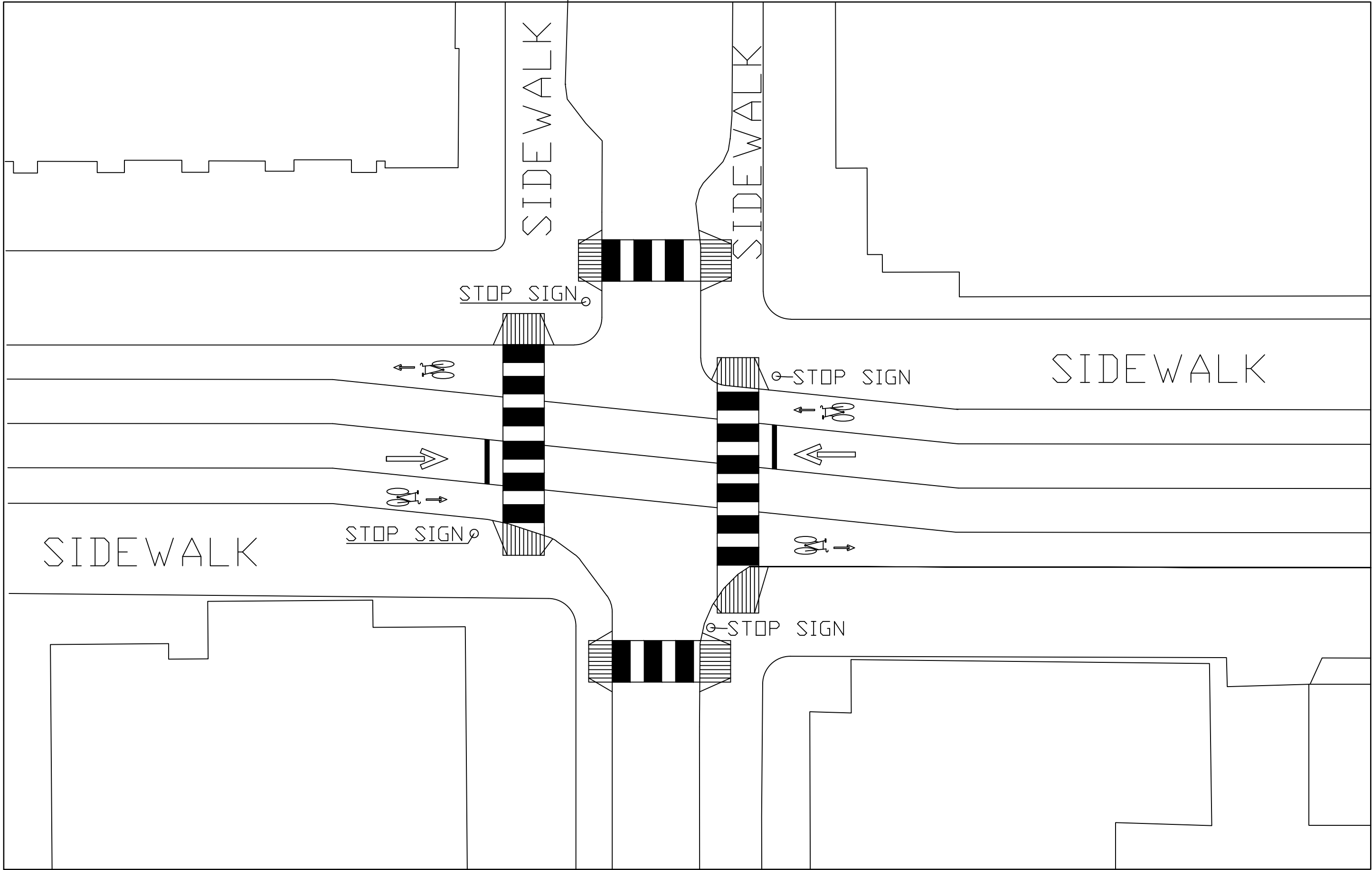

DATE	ISSUED FOR	REV
2021-02-07	50% PROGRESS	A
2021-02-28	90% PROGRESS	B
2021-04-12	CONSTRUCTION	C

This drawing has been prepared solely for the use of the CLIENT and there are no representations of any kind made by Team 16 Architects Engineers Planners to any party with who Team 16 Architects Engineers Planners has not entered into a contract. This drawing shall not be used for construction purposes until the seal appearing hereon is signed and dated by the Architect or Engineer.

Consultants  
 Civil: TEAM 16  
 Landscape: TEAM 16  
 Architectural: TEAM 16  
 Structural: TEAM 16

North Arrow

Detail Symbol

Symbol not to scale

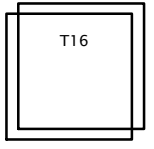

Approval Stamps

Drawn	GRACE WANG
Checked	GRACE WANG
Client	UBC SEEDS
Project	EAST MALL REDESIGN
Drawing Title	AGRONOMY RD BLOCK INTERSECTION
Scale	1:6.5
Project No.	Project #2
Drawing No.	C-05

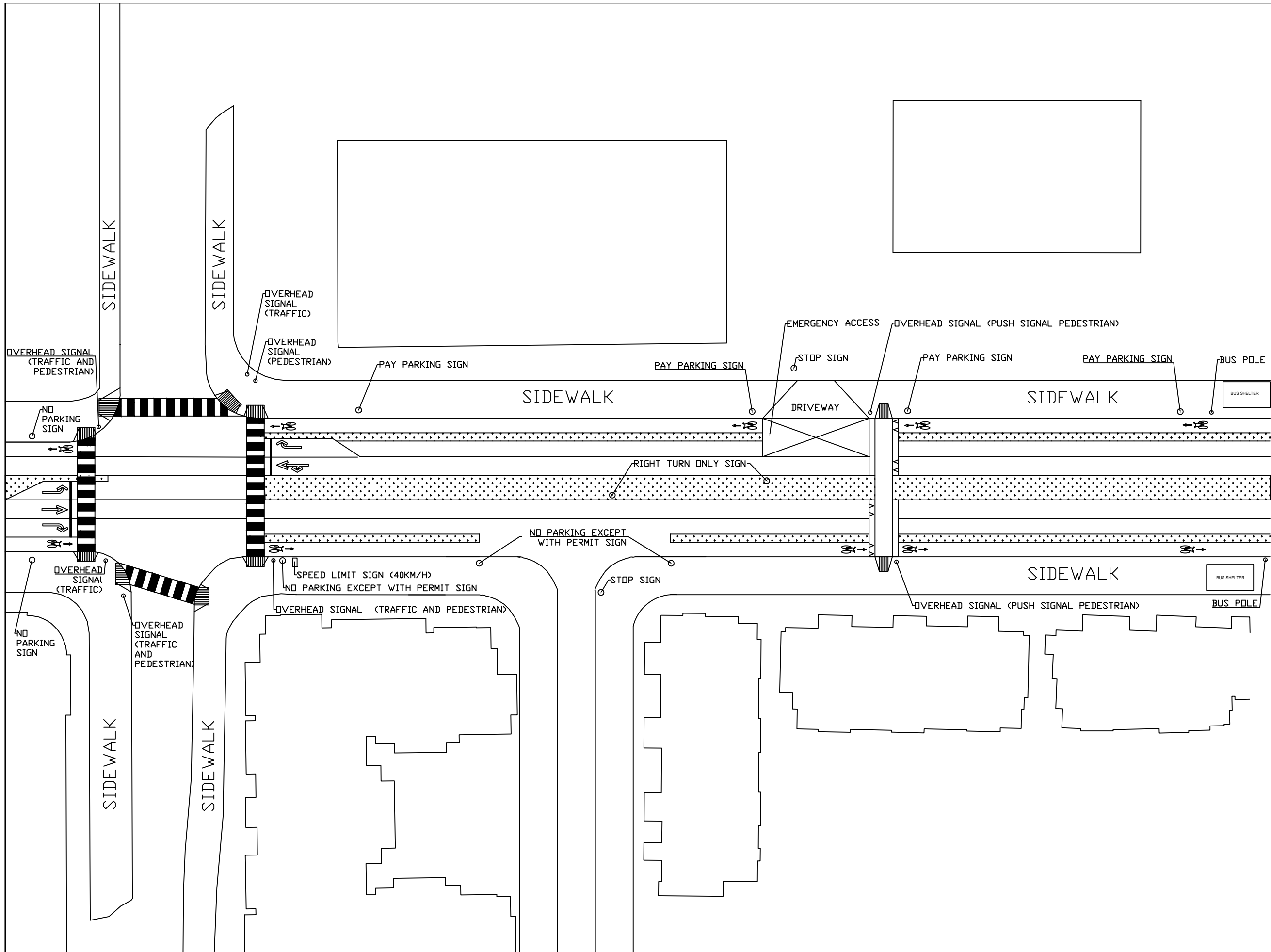

DATE	ISSUED FOR	REV
2021-02-18	50% PROGRESS	A
2021-03-04	90% PROGRESS	B
2021-04-12	FOR CONSTRUCTION	C

This drawing has been prepared solely for the use of the CLIENT and there are no representations of any kind made by Team 16 Architects Engineers Planners to any party with whom Team 16 Architects Engineers Planners has not entered into a contract. This drawing shall not be used for construction purposes until the seal appearing hereon is signed and dated by the Architect or Engineer.

Consultants  
 Civil: TEAM 16  
 Landscape: TEAM 16  
 Architectural: TEAM 16  
 Structural: TEAM 16

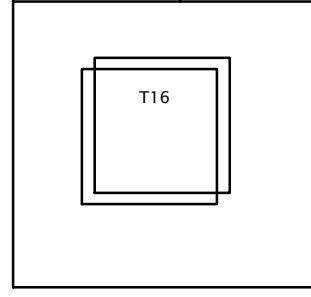
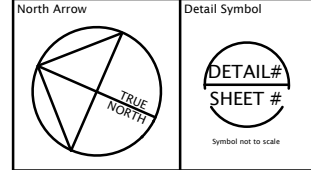

Approval Stamps

Drawn CECILIA YUEN
Checked CECILIA YUEN
Client <b>UBC SEEDS</b>
Project <b>EAST MALL REDESIGN</b>
Drawing Title <b>THUNDERBIRD BLVD BLOCK</b>
Scale <b>1:16</b>
Project No. <b>Project #2</b>
Drawing No. <b>C-06</b>

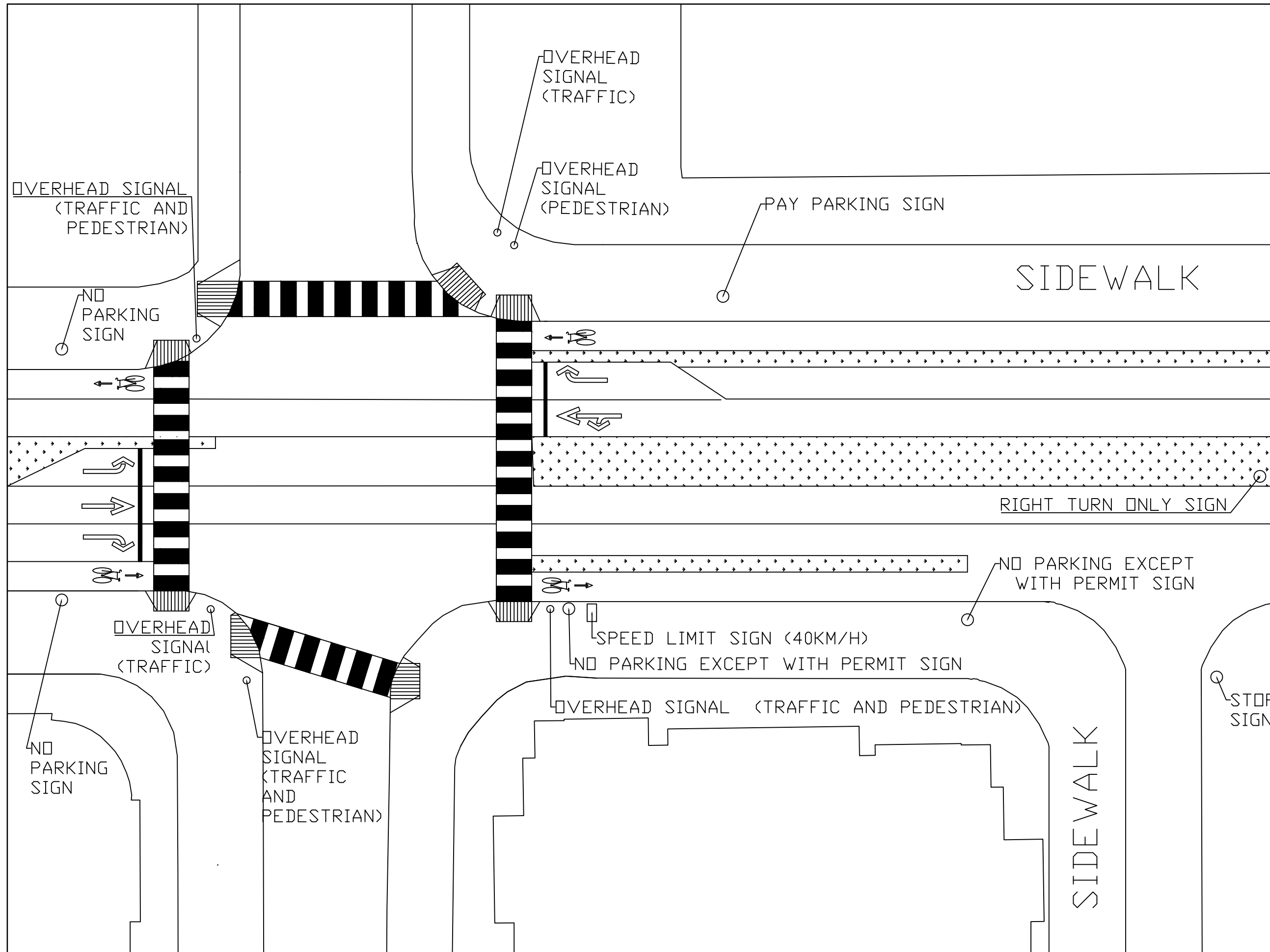

DATE	ISSUED FOR	REV
2021-02-18	50% PROGRESS	A
2021-03-04	90% PROGRESS	B
2021-04-12	FOR CONSTRUCTION	C

This drawing has been prepared solely for the use of the CLIENT and there are no representations of any kind made by Team 16 Architects Engineers Planners to any party with who Team 16 Architects Engineers Planners has not entered into a contract.

This drawing shall not be used for construction purposes until the seal appearing hereon is signed and dated by the Architect or Engineer.

Consultants	
Civil:	TEAM 16
Landscape:	TEAM 16
Architectural:	TEAM 16
Structural:	TEAM 16

North Arrow	Detail Symbol
<small>Symbol not to scale</small>	

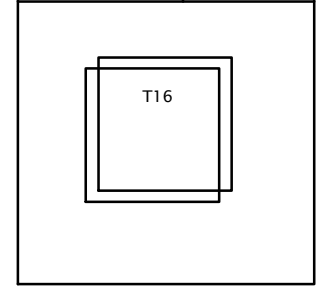

Approval Stamps

Drawn CECILIA YUEN
Checked CECILIA YUEN
Client <b>UBC SEEDS</b>
Project <b>EAST MALL REDESIGN</b>
Drawing Title <b>THUNDERBIRD BLVD INTERSECTION</b>
Scale <b>1:8</b>
Project No. <b>Project #2</b>
Drawing No. <b>C-07</b>

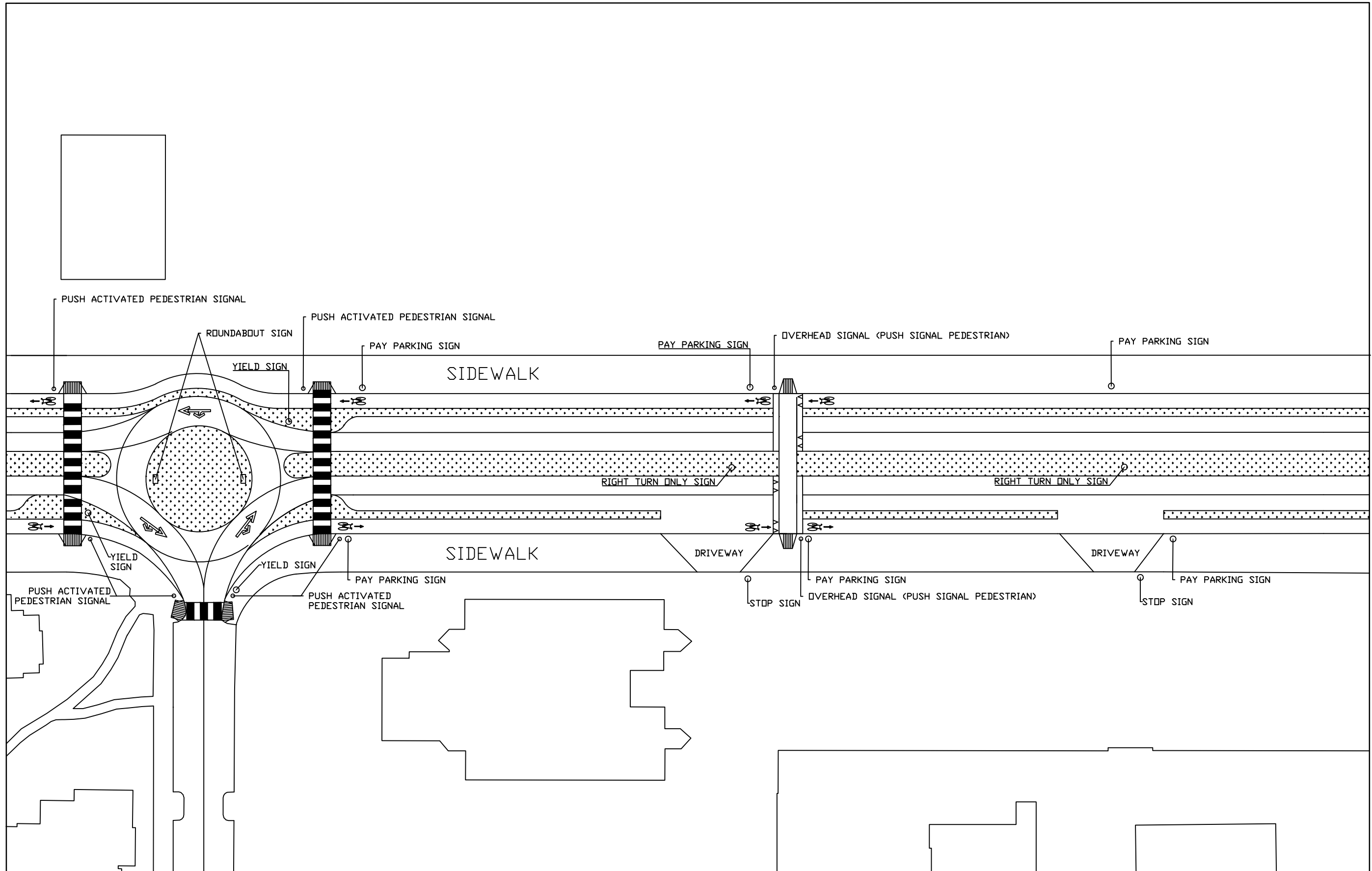

DATE	ISSUED FOR	REV
2021-02-23	50% PROGRESS	A
2021-03-03	90% PROGRESS	B
2021-03-25	FOR CONSTRUCTION	C

This drawing has been prepared solely for the use of the CLIENT and there are no representations of any kind made by Team 16 Architects Engineers Planners to any party with whom Team 16 Architects Engineers Planners has not entered into a contract.

This drawing shall not be used for construction purposes until the seal appearing hereon is signed and dated by the Architect or Engineer.

Consultants  
 Civil: TEAM 16  
 Landscape: TEAM 16  
 Architectural: TEAM 16  
 Structural: TEAM 16

North Arrow

Detail Symbol

Symbol not to scale

T16

Approval Stamps

Drawn  
LILIAN VUONG

Checked  
LILIAN VUONG

Client  
**UBC SEEDS**

Project  
**EAST MALL REDESIGN**

Drawing Title  
**EAGLES DR BLOCK**

Scale  
**1:16**

Project No. **Project #2**

Drawing No. **C-08**



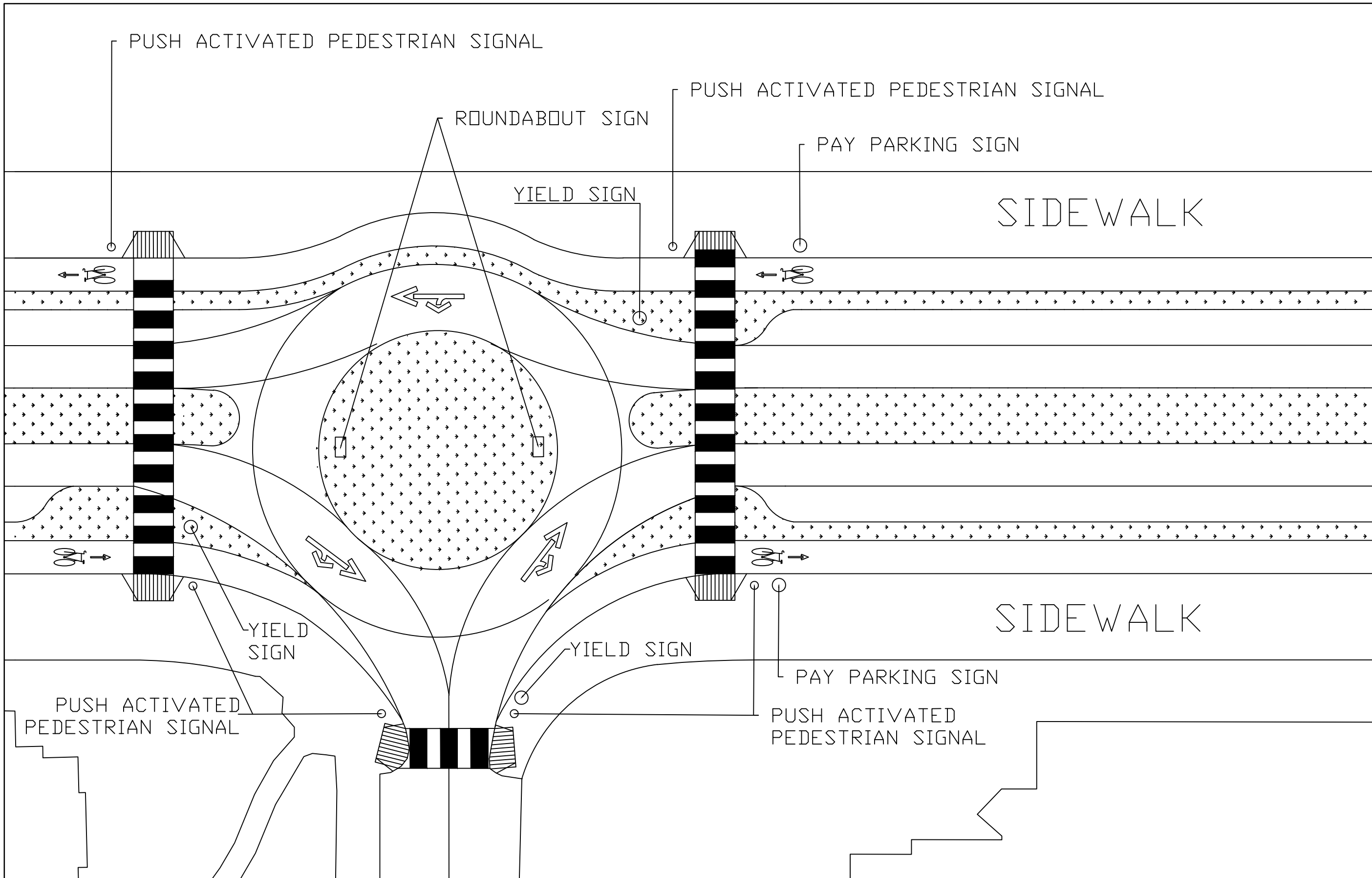

DATE	ISSUED FOR	REV
2021-02-23	50% PROGRESS	A
2021-03-03	90% PROGRESS	B
2021-03-25	FOR CONSTRUCTION	C

This drawing has been prepared solely for the use of the CLIENT and there are no representations of any kind made by Team 16 Architects Engineers Planners to any party with who Team 16 Architects Engineers Planners has not entered into a contract.

This drawing shall not be used for construction purposes until the seal appearing hereon is signed and dated by the Architect or Engineer.

Consultants  
 Civil: TEAM 16  
 Landscape: TEAM 16  
 Architectural: TEAM 16  
 Structural: TEAM 16

North Arrow

Detail Symbol

T16

Approval Stamps

Drawn  
LILIAN VUONG

Checked  
LILIAN VUONG

Client  
UBC SEEDS

Project  
EAST MALL REDESIGN

Drawing Title  
EAGLES DR BLOCK INTERSECTION

Scale  
1:7

Project No.  
Project #2

Drawing No.  
C-09

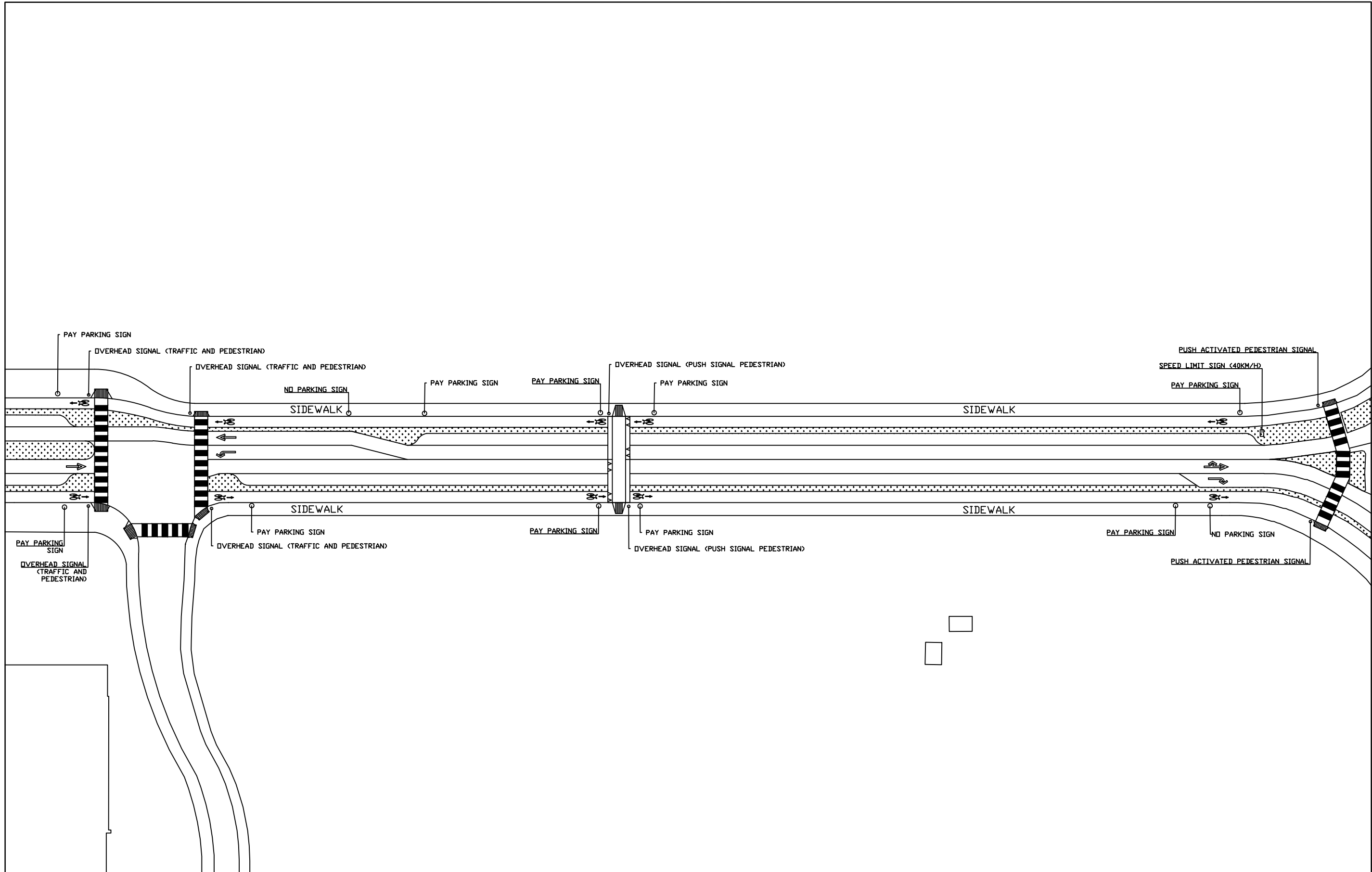

DATE	ISSUED FOR	REV
2021-02-19	50% PROGRESS	A
2021-03-03	90% PROGRESS	B
2021-03-25	FOR CONSTRUCTION	C

This drawing has been prepared solely for the use of the CLIENT and there are no representations of any kind made by Team 16 Architects Engineers Planners to any party with who Team 16 Architects Engineers Planners has not entered into a contract.

This drawing shall not be used for construction purposes until the seal appearing hereon is signed and dated by the Architect or Engineer.

Consultants  
 Civil: TEAM 16  
 Landscape: TEAM 16  
 Architectural: TEAM 16  
 Structural: TEAM 16

North Arrow

Detail Symbol

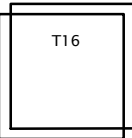

Approval Stamps

Drawn  
LILIAN VUONG

Checked  
LILIAN VUONG

Client  
**UBC SEEDS**

Project  
**EAST MALL REDESIGN**

Drawing Title  
**STADIUM RD BLOCK**

Scale  
1:21

Project No. Project #2

Drawing No. C-10

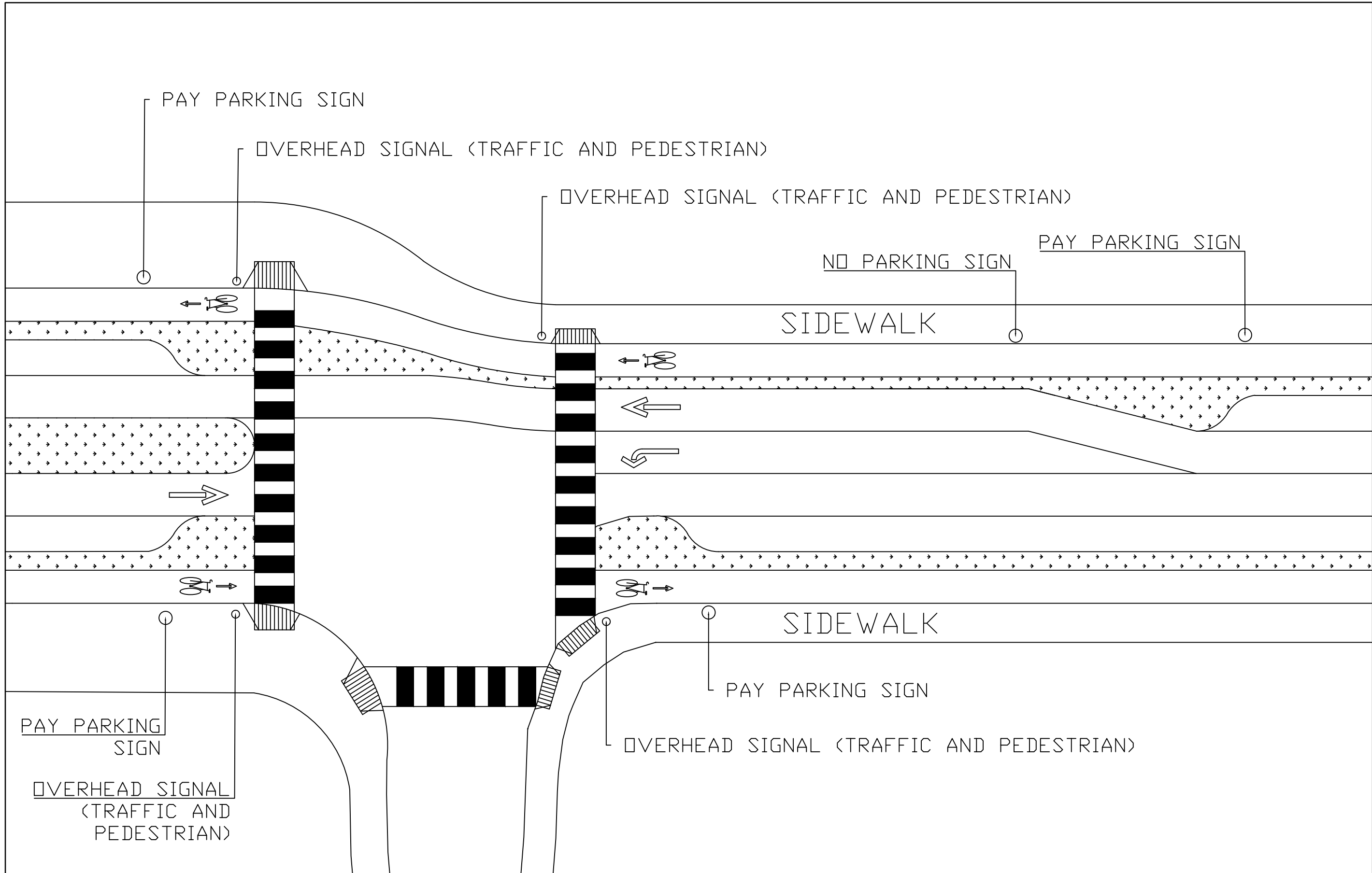

DATE	ISSUED FOR	REV
2021-02-19	50% PROGRESS	A
2021-03-03	90% PROGRESS	B
2021-03-25	FOR CONSTRUCTION	C

This drawing has been prepared solely for the use of the CLIENT and there are no representations of any kind made by Team 16 Architects Engineers Planners to any party with who Team 16 Architects Engineers Planners has not entered into a contract. This drawing shall not be used for construction purposes until the seal appearing hereon is signed and dated by the Architect or Engineer.

Consultants  
 Civil: TEAM 16  
 Landscape: TEAM 16  
 Architectural: TEAM 16  
 Structural: TEAM 16

North Arrow

Detail Symbol

Symbol not to scale

T16

Approval Stamps

Drawn: LILIAN VUONG  
 Checked: LILIAN VUONG  
 Client: UBC SEEDS  
 Project: EAST MALL REDESIGN  
 Drawing Title: STADIUM RD BLOCK INTERSECTION  
 Scale: 1:7  
 Project No.: Project #2  
 Drawing No.: C-11

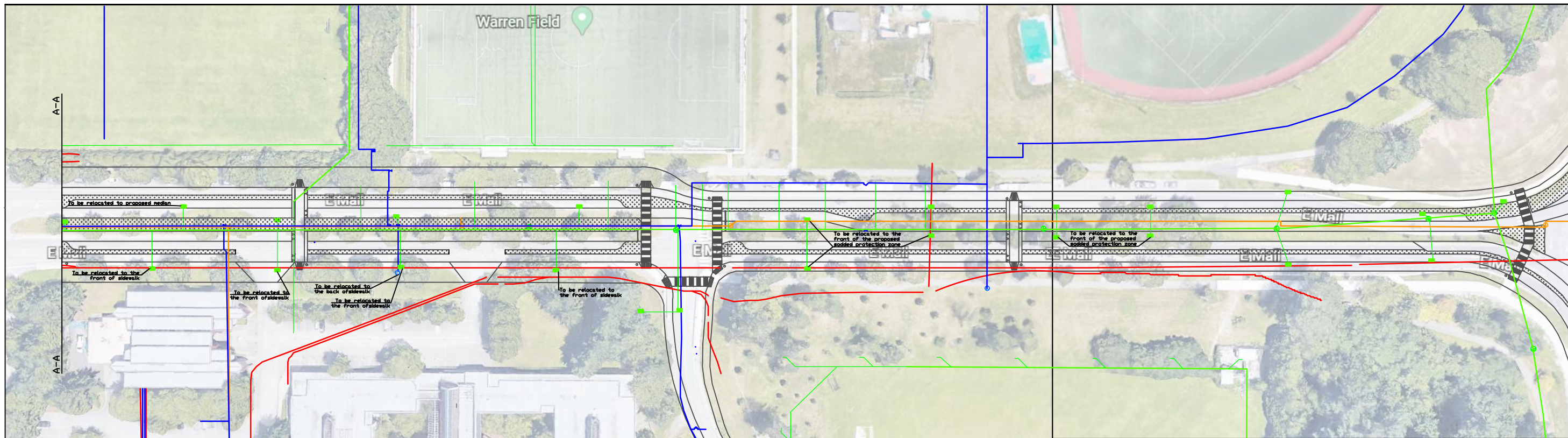
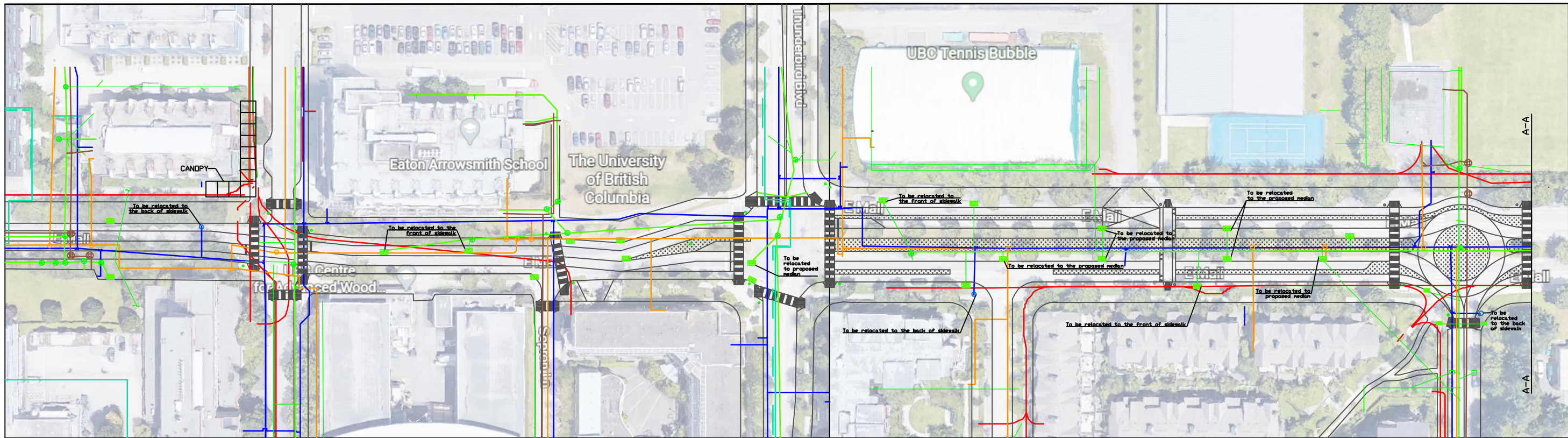

DATE	ISSUED FOR	REV
2021-02-19	30% PROGRESS	A
2021-03-03	30% PROGRESS	B
2021-03-31	FOR CONSTRUCTION	C

This drawing has been prepared solely for the use of the CLIENT and there are no representations of any kind made by Team 16 Architects Engineers Planners to any party with who Team 16 Architects Engineers Planners has not entered into a contract.

This drawing shall not be used for construction purposes until the seal appearing hereon is signed and dated by the Architect or Engineer.

Consultants:	TEAM 16
Civil:	TEAM 16
Landscaping:	TEAM 16
Architectural:	TEAM 16
Structural:	TEAM 16

North Arrow

Detail Symbol

Symbol not to scale

T16

Legend	
	UTIL Sanitary_Manholes
	UTIL Sanitary_Force_Mains
	UTIL Sanitary_Gravity_Mains
	UTIL STM_Manholes
	UTIL STM_Mains_Misc
	UTIL STM_Mains
	FIRE HYDRANT
	UTIL WAT_VALVES
	UTIL WAT_ACTIVE_MAINS
	UTIL gas_valves
	UTIL gas_mains
	UTIL des_pipe_return
	UTIL des_pipe_supply
	UTIL des_valves
	UTIL elec_line
	UTIL STM_Ditch
	UTIL STM_CatchBasin

Drawn:	FIONA ZHANG
Checked:	LILIAN VUONG

Client: UBC SEEDS

Project: EAST MALL REDESIGN

Drawing Title: EAST MALL UTILITIES

Scale: 1:33

Project No.: Project #2

Drawing No.: C-12

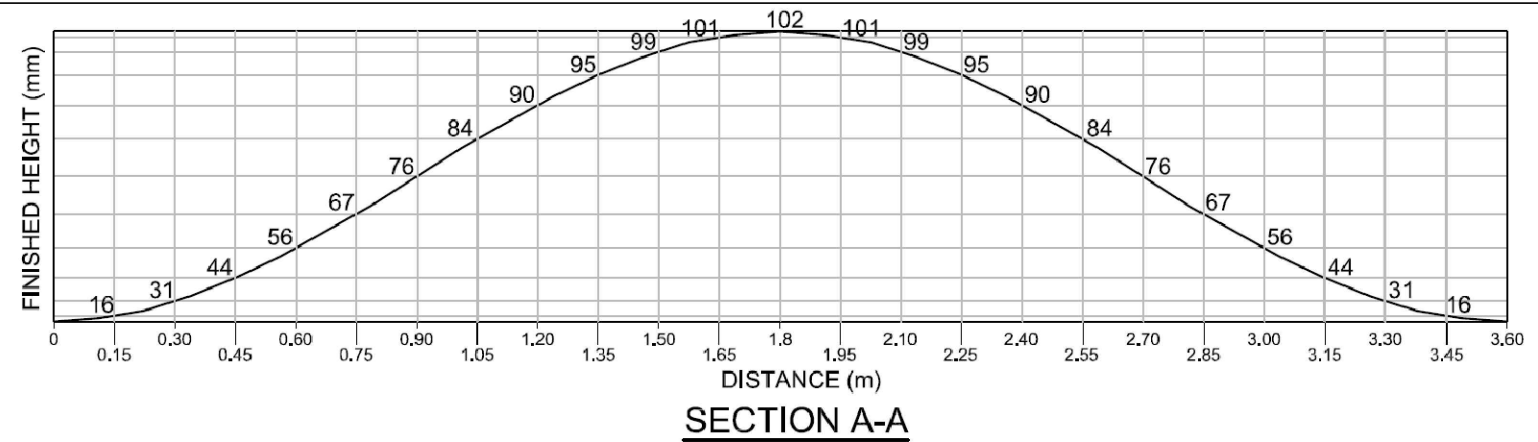
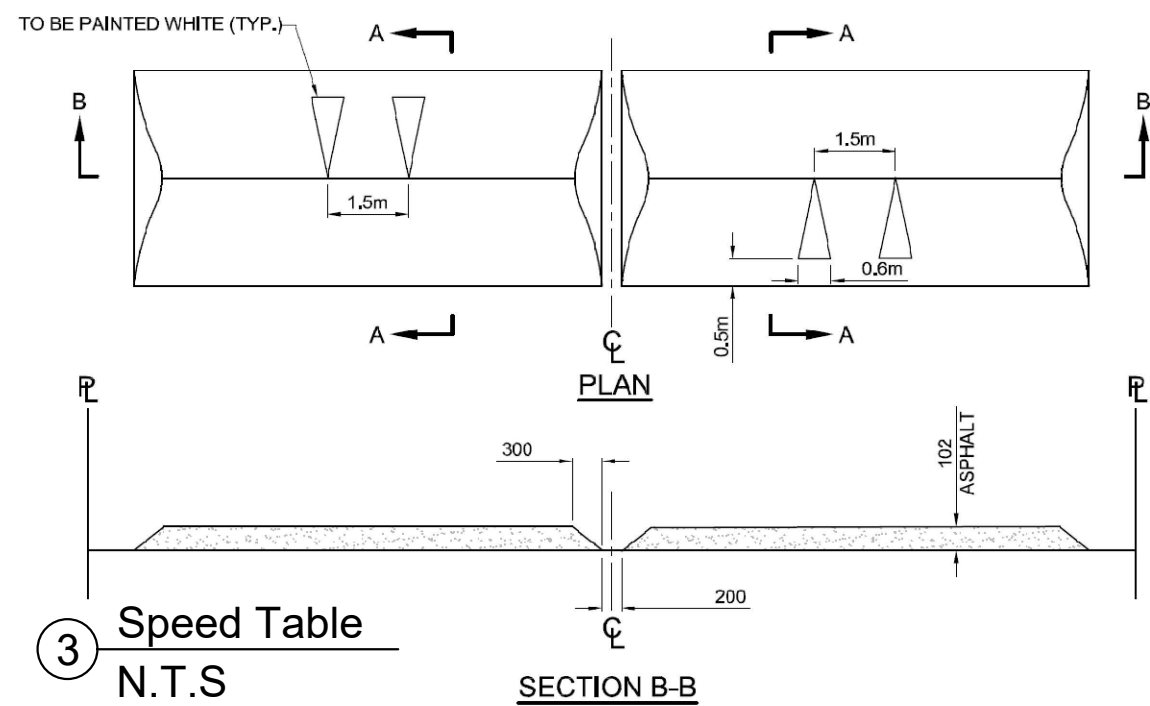

DISTANCE (m)	0	0.150	0.300	0.450	0.600	0.750	0.900	1.050	1.200	1.350	1.500	1.650	1.800
FINISHED HEIGHT (mm)	0	16	31	44	56	67	76	84	90	95	99	101	102

SINUSOIDAL SPEED HUMP DEVELOPMENT

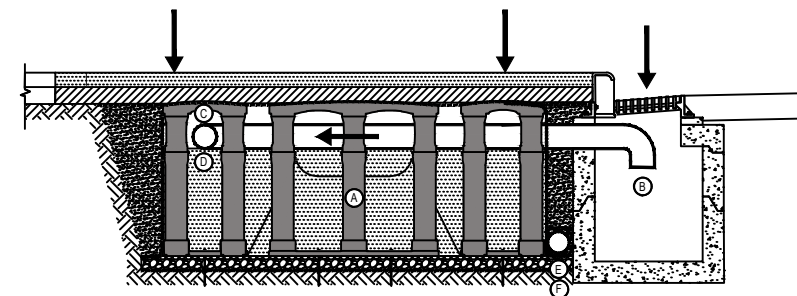
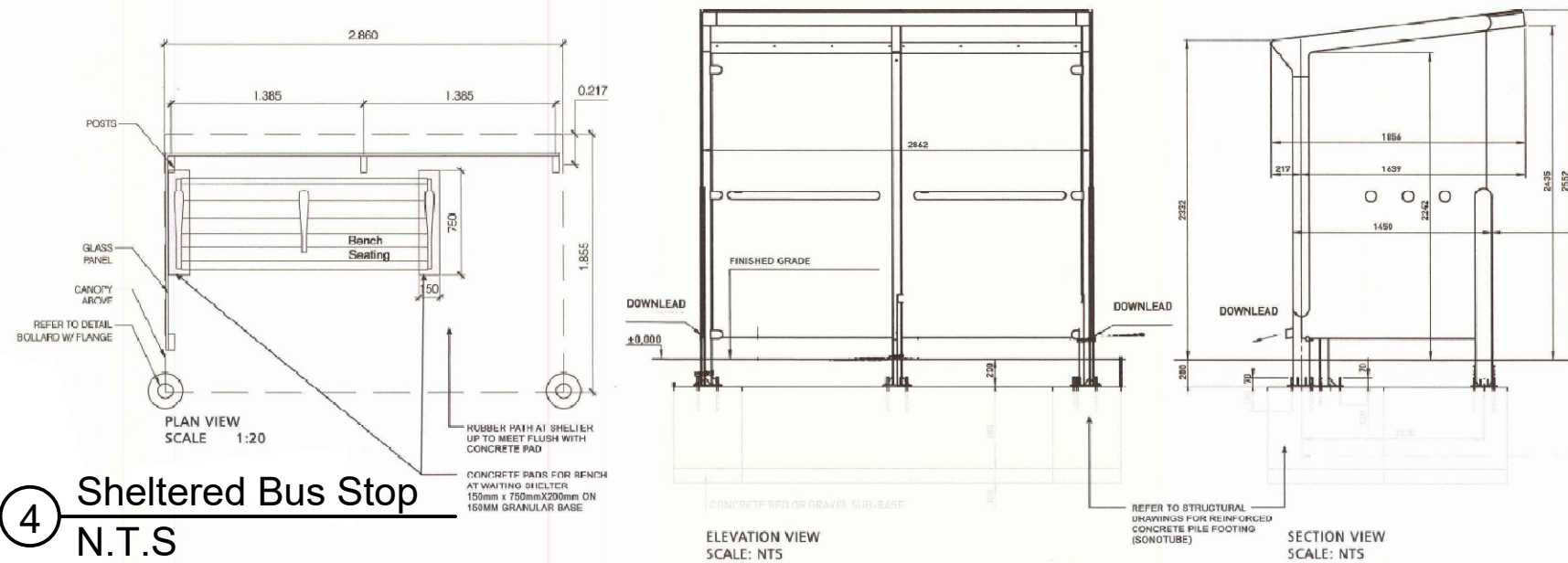

DATE	ISSUED FOR	REV
2020-12-03	50% PROGRESS	A
2021-03-05	90% PROGRESS	B
2021-04-12	ISSUED FOR CONSTRUCTION	C

This drawing has been prepared solely for the use of the CLIENT and there are no representations of any kind made by Team 16 Architects Engineers Planners to any party with who Team 16 Architects Engineers Planners has not entered into a contract.  
 This drawing shall not be used for construction purposes until the seal appearing hereon is signed and dated by the Architect or Engineer.

Note  
 Detail 3 and 4 are adopted from City of Vancouver Standard Detail Drawings. Detail 5 is adopted from Deeproot Silva Cell drawings.

Consultants	TEAM 16
Civil:	TEAM 16
Landscape:	TEAM 16
Architectural:	TEAM 16
Structural:	TEAM 16

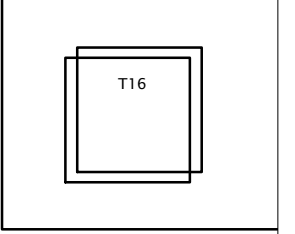
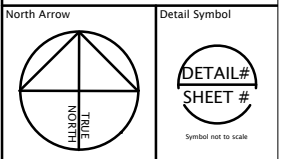

Drawn	FIONA ZHANG
Checked	FIONA ZHANG
Client	UBC SEEDS
Project	EAST MALL REDESIGN
Drawing Title	STANDARD DETAILS - 1
Scale	N.T.S
Project No.	Project #2
Drawing No.	C-13

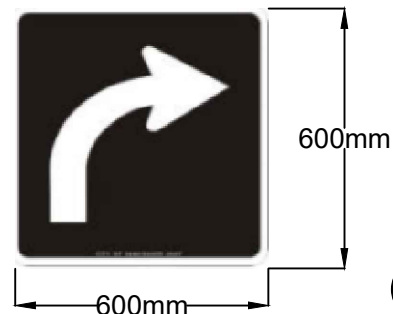
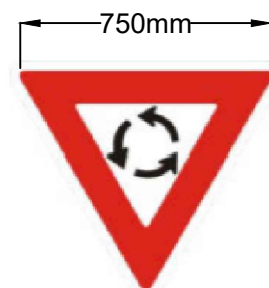
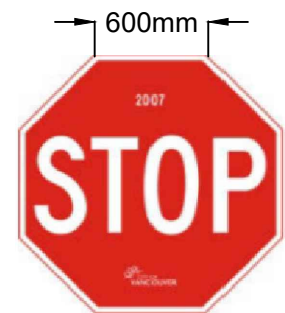
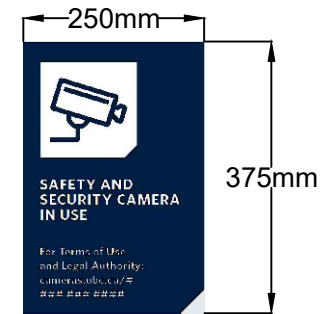
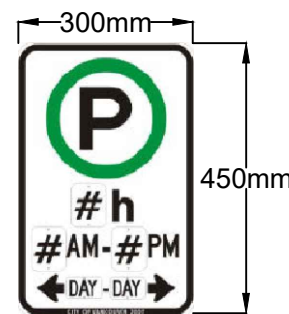
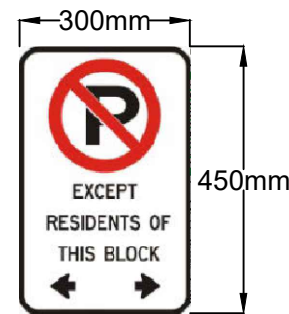
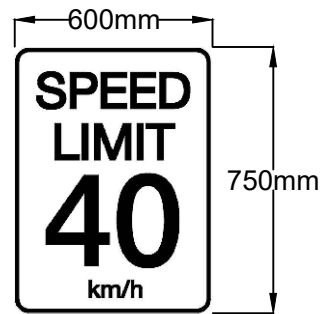
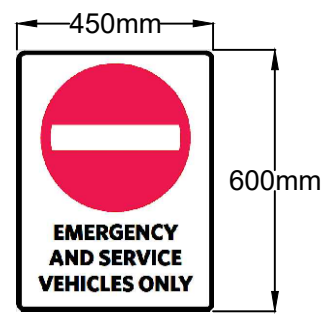
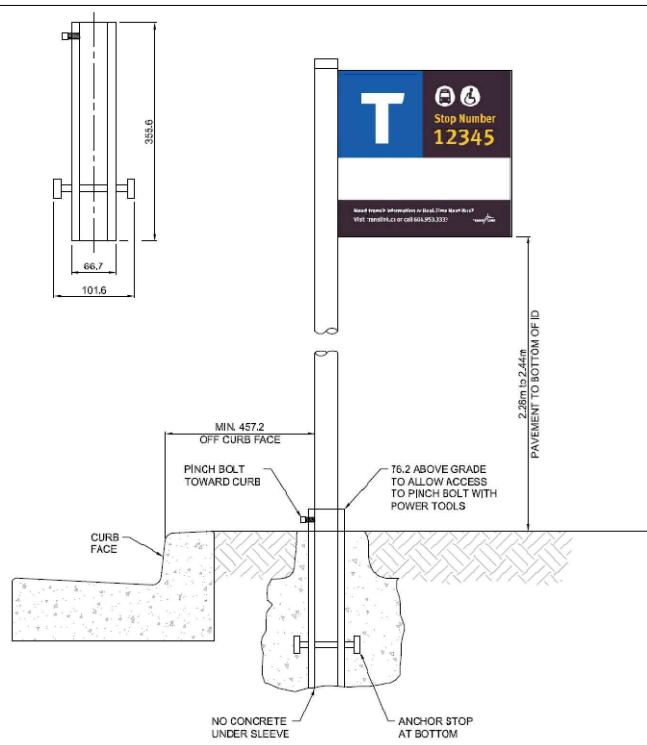

① **Traffic Signs and Sign Post**  
N.T.S

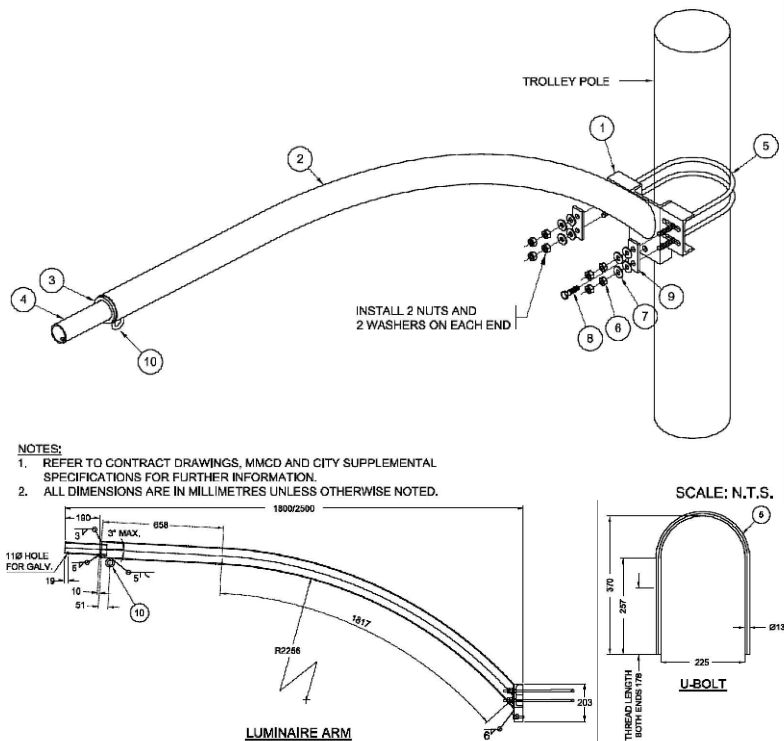
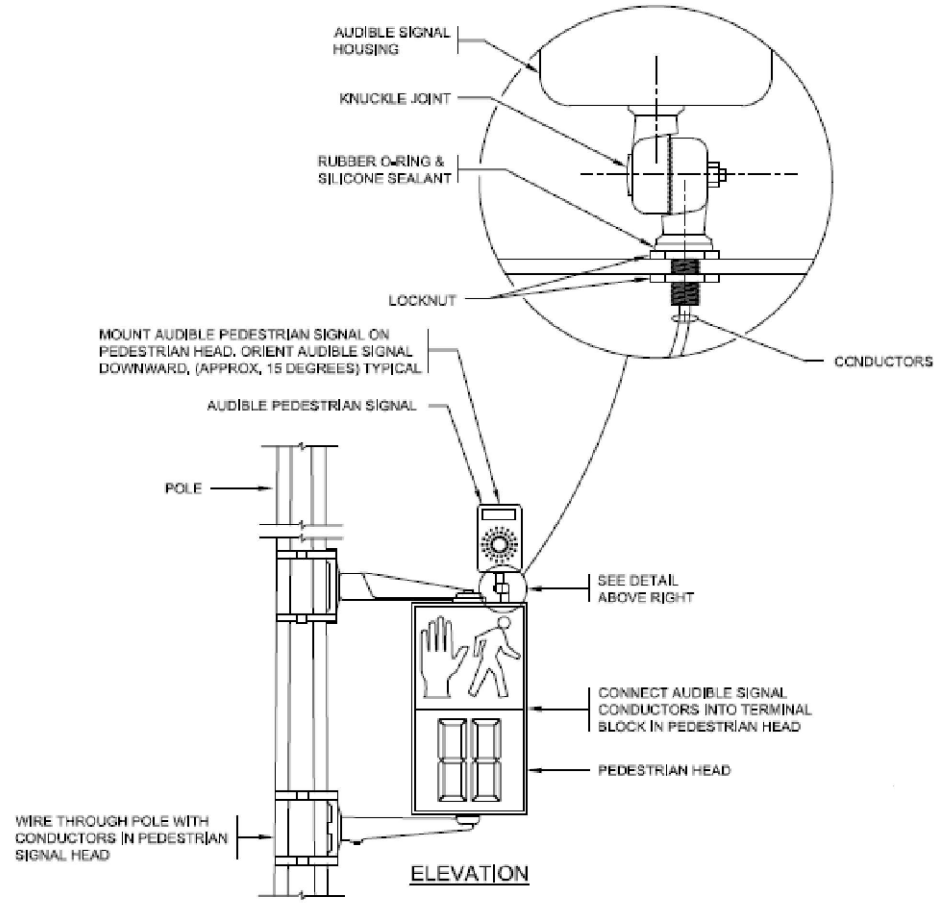
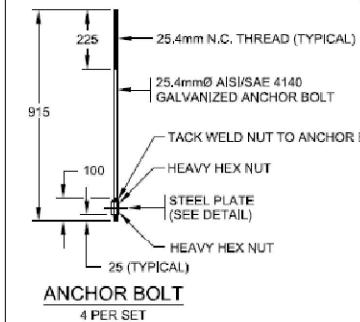
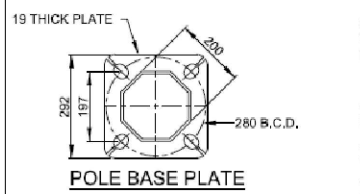
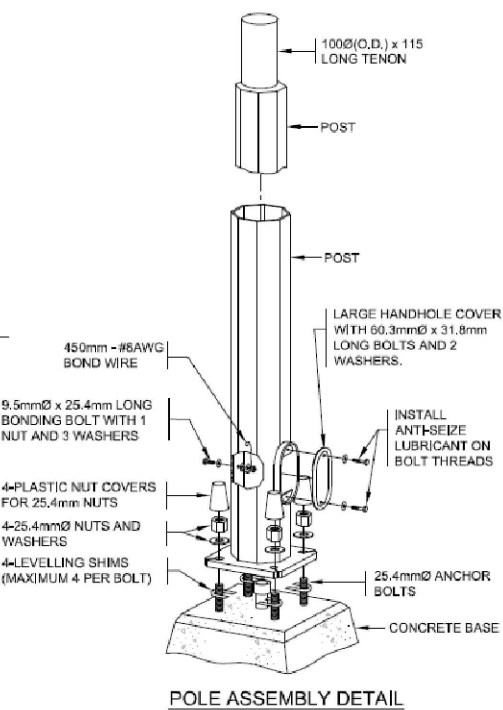
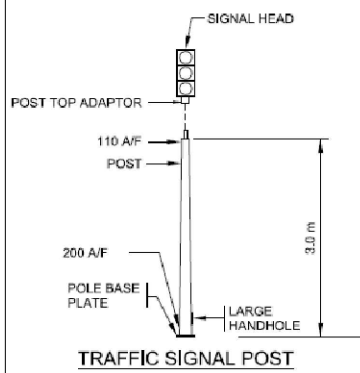

② **Traffic Signal Post**  
N.T.S

DATE	ISSUED FOR	REV
2020-12-03	50% PROGRESS	A
2021-03-05	90% PROGRESS	B
2021-04-12	ISSUED FOR CONSTRUCTION	C

This drawing has been prepared solely for the use of the CLIENT and there are no representations of any kind made by Team 16 Architects Engineers Planners to any party with who Team 16 Architects Engineers Planners has not entered into a contract. This drawing shall not be used for construction purposes until the seal appearing hereon is signed and dated by the Architect or Engineer.

Note  
Detail 1 and 2 are adopted from City of Vancouver Standard Detail Drawings.  
Sign drawings are adopted from City of Vancouver Standard Detail Drawings and UBC Wayfinding Exterior Signage Standards and Guidelines.

Consultants	TEAM 16
Civil:	TEAM 16
Landscape:	TEAM 16
Architectural:	TEAM 16
Structural:	TEAM 16

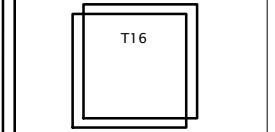
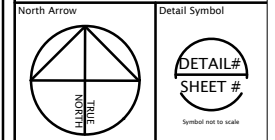

Drawn	FIONA ZHANG
Checked	FIONA ZHANG
Client	UBC SEEDS
Project	EAST MALL REDESIGN
Drawing Title	Standard Details - 2
Scale	N.T.S
Project No.	Project #2
Drawing No.	C-14

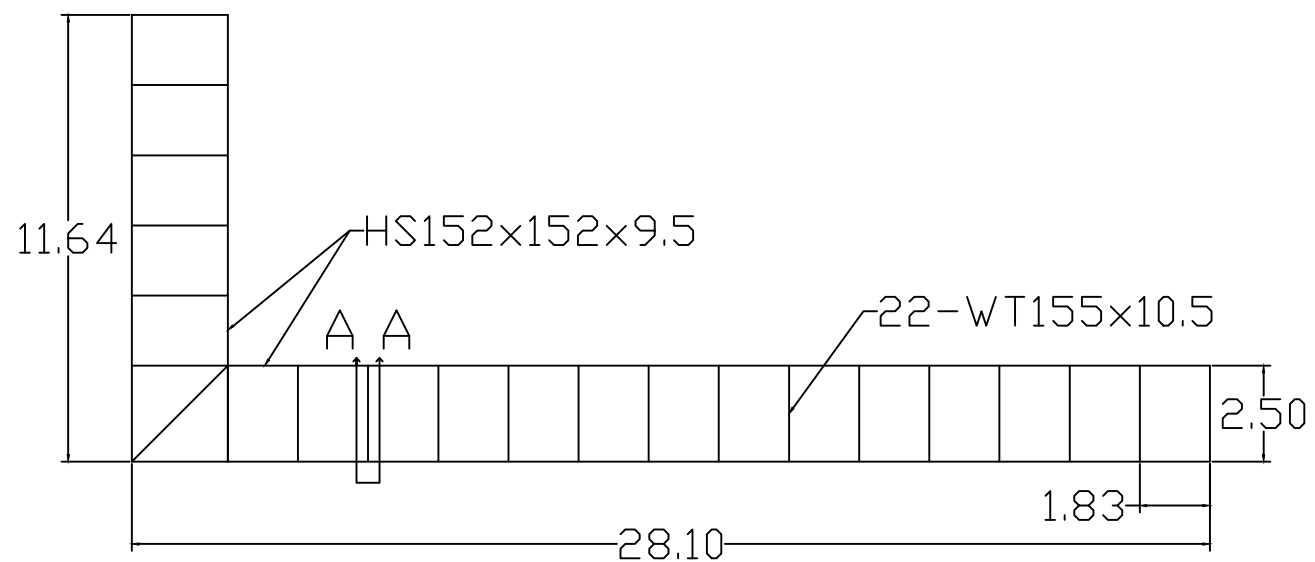

Plan View  
Scale 1:5

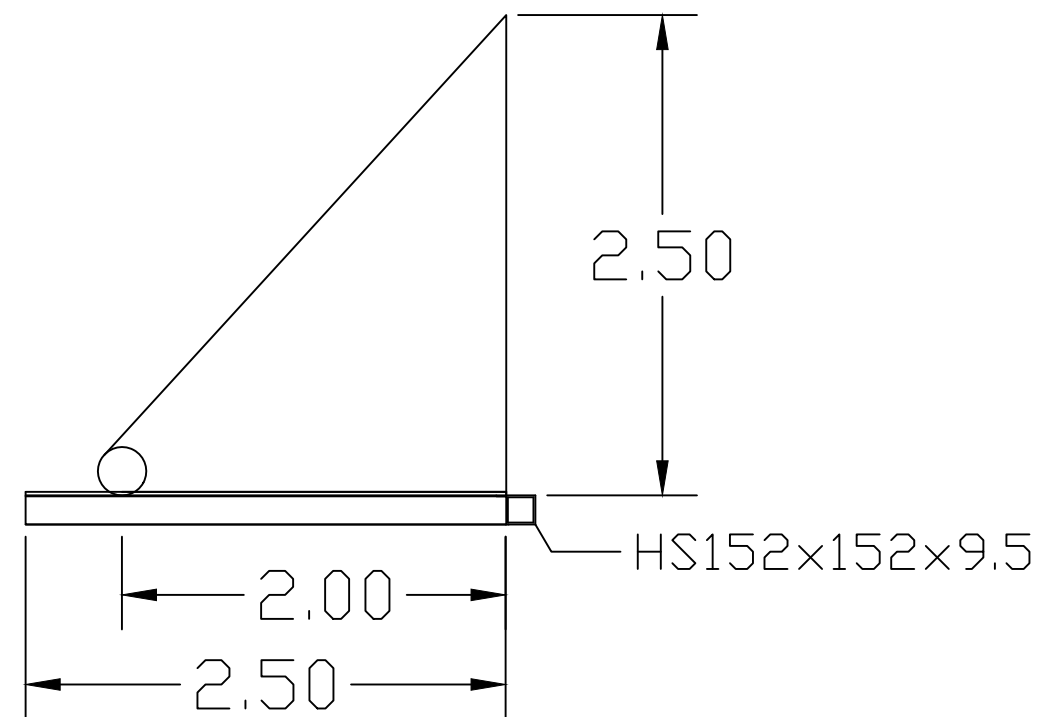

Side View  
Scale 1:1

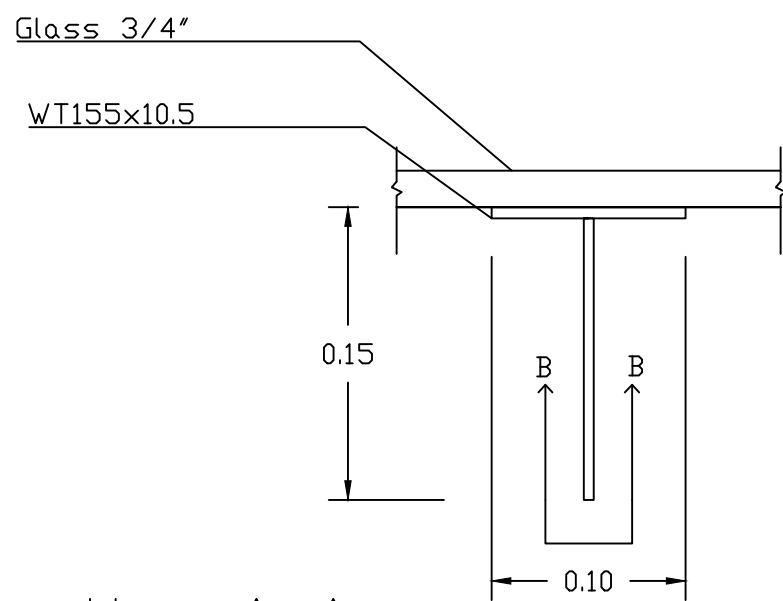

Section A-A  
Scale 10:1

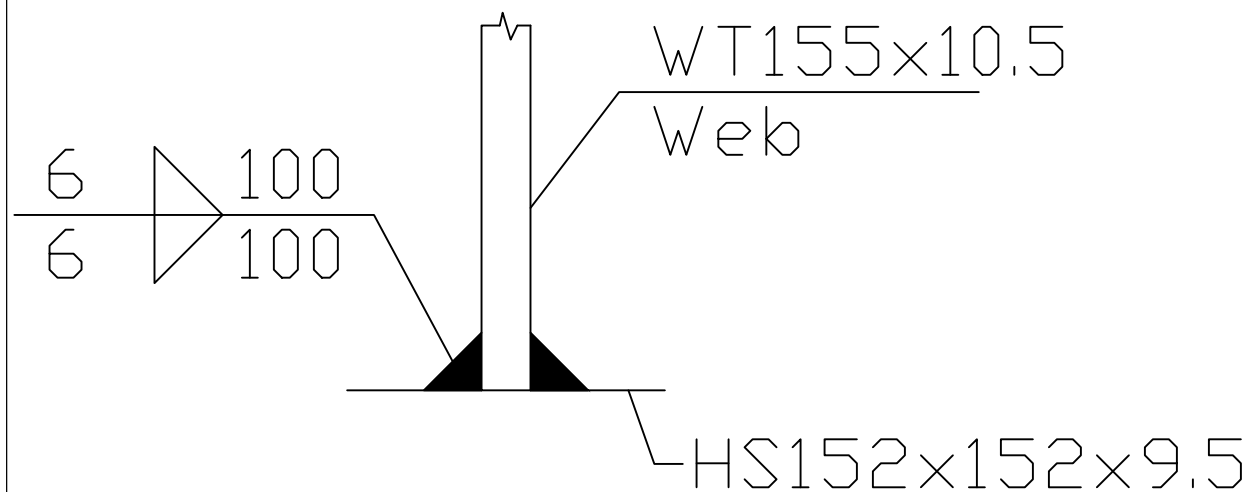

Section B-B  
Scale 50:1

DATE	ISSUED FOR	REV
2020-11-17	60% PROGRESS	A
2021-02-23	90% PROGRESS	B
2021-04-12	FOR CONSTRUCTION	C

This drawing has been prepared solely for the use of the CLIENT and there are no representations of any kind made by Team 16 Architects Engineers Planners to any party with who Team 16 Architects Engineers Planners has not entered into a contract.  
This drawing shall not be used for construction purposes until the seal appearing hereon is signed and dated by the Architect or Engineer.

Consultants  
Civil: TEAM 16  
Landscape: TEAM 16  
Architectural: TEAM 16  
Structural: TEAM 16

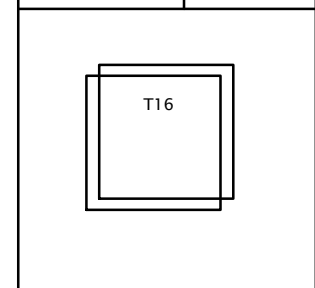
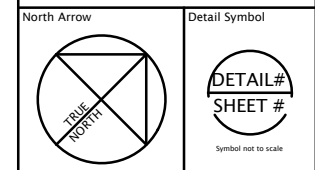

Approval Stamps

Drawn Rocky Chen
Checked Cecilia Yuen
Client UBC SEEDS
Project EAST MALL REDESIGN
Drawing Title Canopy
Scale Varies
Project No. Project #2
Drawing No. S-01

## **Appendix B: Synchro Results**



B1. Original Design Results

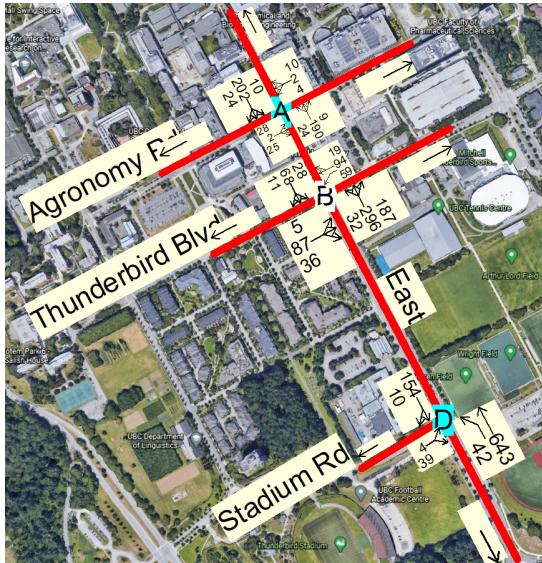

Figure B1.1: Original Design LOS Peak AM, Growth Factor 1.0

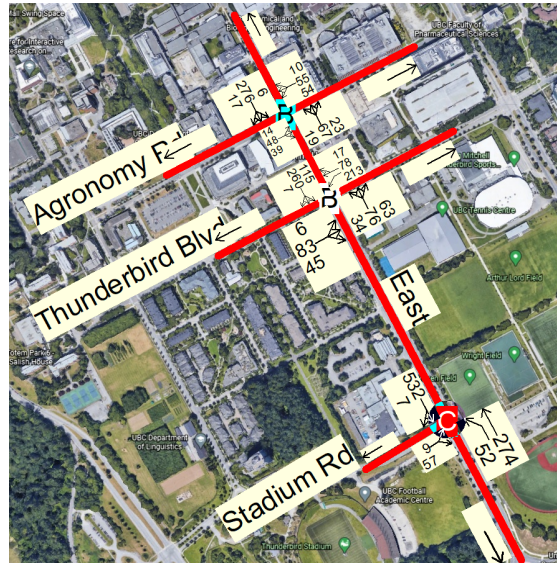

Figure B1.2: Original Design LOS Peak PM, Growth Factor 1.0

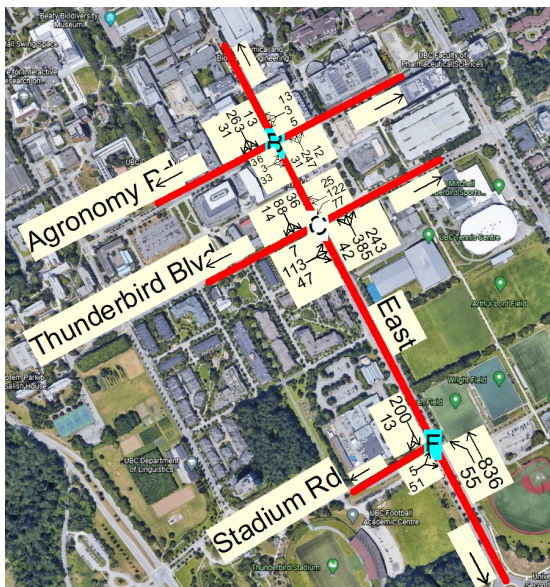

Figure B1.3: Original Design LOS Peak AM, Growth Factor 1.3

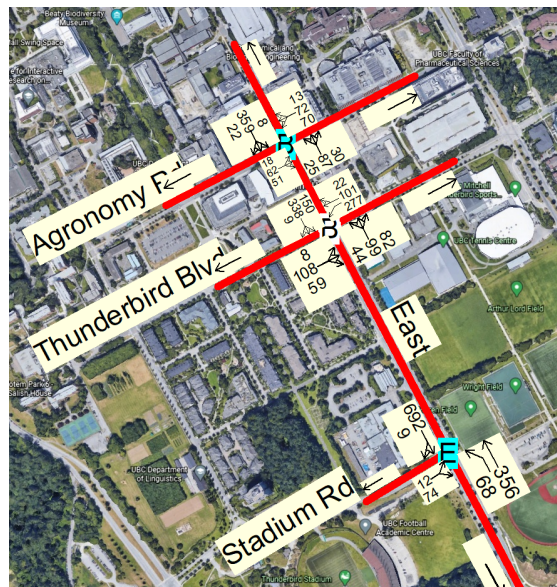

Figure B1.4: Original Design LOS Peak PM, Growth Factor 1.3

B2. Preliminary Design Results

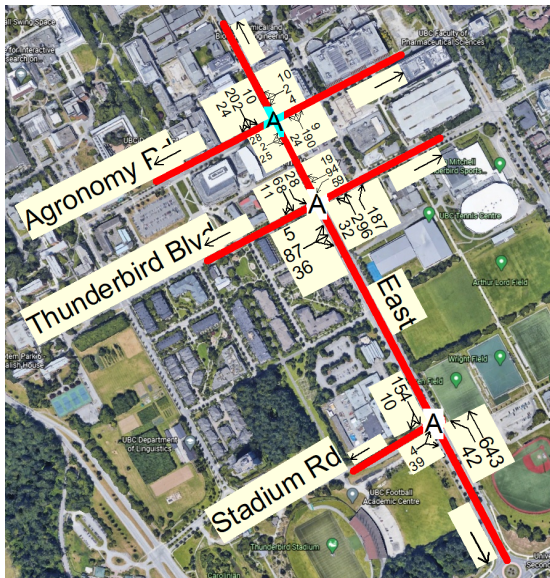

Figure B2.1: Preliminary Design LOS Peak AM, Growth Factor 1.0

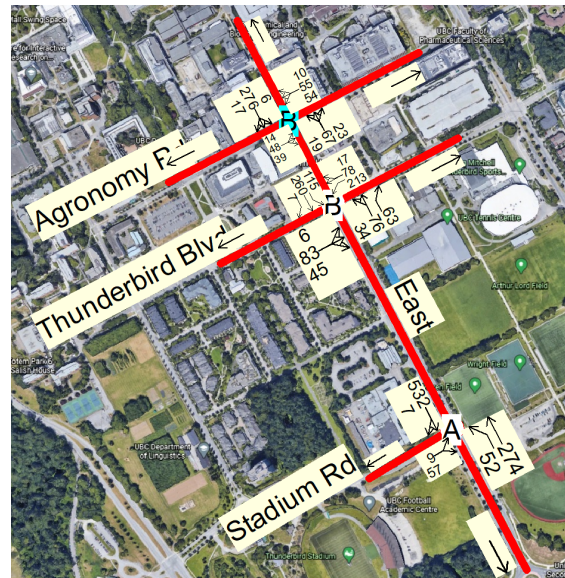

Figure B2.2: Preliminary Design LOS Peak PM, Growth Factor 1.0

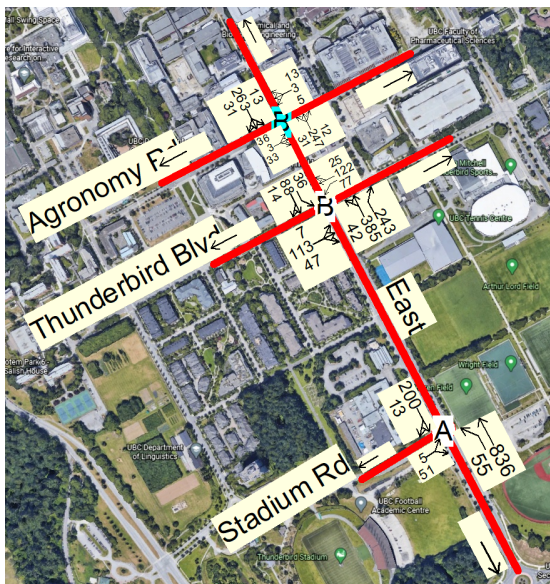

Figure B2.3: Preliminary Design LOS Peak AM, Growth Factor 1.3

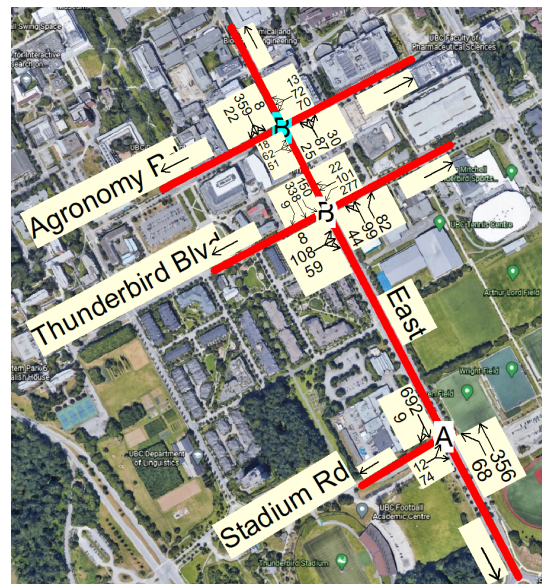

Figure B2.4: Preliminary Design LOS Peak PM, Growth Factor 1.3

## **Appendix C: Structural Analysis Results**

**STEEL TEE-BEAM**

From CISC Steel Catalogue

D	B	T	W	BT	HW	K	K1	Dnom	Mass	A	Ix	Sx	Rx	Y	Iy	Sy	Ry	J	Cw
mm	mm	mm	mm			mm	mm	mm	kg/m	mm <sup>2</sup>	10 <sup>6</sup> mm <sup>4</sup>	10 <sup>3</sup> mm <sup>3</sup>	mm	mm	10 <sup>6</sup> mm <sup>4</sup>	10 <sup>3</sup> mm <sup>3</sup>	mm	10 <sup>3</sup> mm <sup>4</sup>	10 <sup>9</sup> mm <sup>6</sup>
152	101	5.7	5.1	8.86	28.7	18	14	155	10.5	1350	3.25	30.3	49.1	45	0.491	9.73	19.1	14.6	0.0136

Steel Section	WT155x10.5	
Length of beam	2500	mm
Fy =	350	MPa
Fu =	450	MPa
Self-weight	103	N/m
Factored self-weight	129	N/m

**LAMINATED GLASS**

1. 3/4" glass		
Width (w) =	1830	mm
Thickness (t) =	19.1	mm
Depth (d) =	2500	mm
Density (imperial) =	9.53	lb/ft <sup>2</sup>
Density (metric) =	46.5	kg/m <sup>2</sup>
Unit weight =	456.2	N/m <sup>2</sup>
Unit volume =	23883	N/m <sup>3</sup>

Distributed load	835	N/m
------------------	-----	-----

**CABLE**

Diameter	26	mm
----------	----	----

**HSS**

From CISC Steel Catalogue

D	B	T	Tdes	RI	RO	BT	DT	Dnom	Mass	A	Ix	Sx	Rx	Zx	Iy	Sy	Ry	Zy	J
mm	mm	mm	mm	mm	mm	mm	mm	mm	kg/m	mm <sup>2</sup>	10 <sup>6</sup> mm <sup>4</sup>	10 <sup>3</sup> mm <sup>3</sup>	mm	10 <sup>3</sup> mm <sup>3</sup>	10 <sup>6</sup> mm <sup>4</sup>	10 <sup>3</sup> mm <sup>3</sup>	mm	10 <sup>3</sup> mm <sup>3</sup>	10 <sup>3</sup> mm <sup>4</sup>
152.4	152.4	9.53	9.53	9.53	19.06	12	12	152	40.9	5210	17.3	227	57.6	275	17.3	227	57.6	275	28500

Steel Section	152 x 152 x 9.5	
Length of HSS	39.7	m
Fy =	350	MPa
Fu =	450	MPa
Self-weight	401	N/m
Factored self-weight	502	N/m

## Load Combination

\*Using load combination from NBCC. Earthquake load will be neglected in the structural analysis

Case	Load Combination				
	Principal Loads				
	D	L	S	W	E
1	1.4	1.5			
2	1.25		1.5		
3	1.25			1.4	
4	1.25				1
5	1				1

Case 1	$1.4D + 1.5 L$	=	1.31	kN/m
Case 2	$1.25D + 1.5S$	=	6.39	kN/m
Case 3	$1.25D + 1.4 W$	=	2.40	kN/m
Case 4	$1.25D$	=	1.17	kN/m
Case 5	$1D$	=	0.94	kN/m

Governing Load Case Case 2  
 Corresponding loading wf = 6.39 kN/m

## Dead Load Calculation

Mass of steel frame	(from catalogue)	=	10.5	kg/m
UDL from steel frame self-weight		UDL <sub>s</sub> =	0.1	kN/m
Unit-weight of glass	(from catalogue)	=	0.5	kN/m <sup>2</sup>
UDL from glass self-weight		UDL <sub>g</sub> =	0.835	kN/m
Total dead load		DL =	0.938	kN/m

## Snow Load Calculation

Specified snow load	NBCC Cl.9.4.2.3.	=	1.9	kPa
Snow Load		S =	3.477	kN/m

## Wind Load Calculation

Probability of wind load	NBCC Part 4	=	0.02	
Specified wind load	NBCC Part 4	=	0.48	kPa
Wind load		W =	0.8784	kN/m

## Moment and shear demand

The structure has been modeled on SAP2000 to perform structural analysis under the load calculated above, see below for the force output from SAP2000.

From SAP2000:

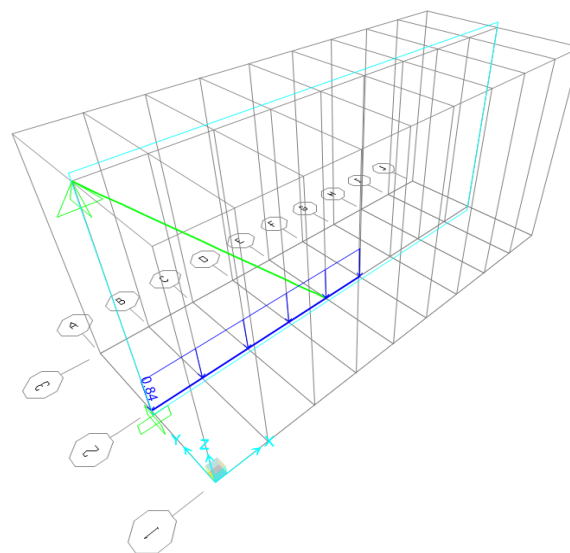
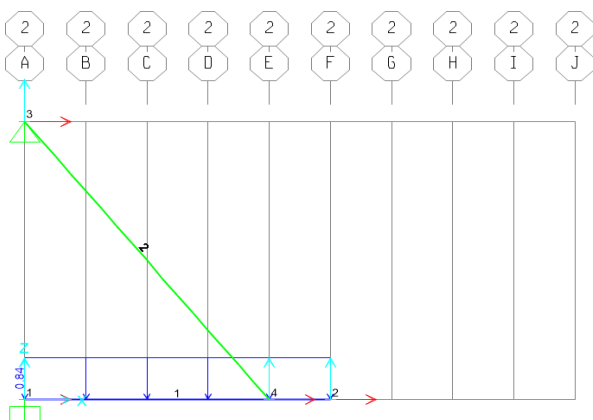

Element Forces - Frames

File View Edit Format-Filter-Sort Select Options

Units: As Noted

Filter:

Frame Text	Station m	OutputCase	CaseType Text	P KN	V2 KN	V3 KN	T KN-m	M2 KN-m	M3 KN-m	FrameElem Text	Elem
1	0	COMB1	Combination	-8.516	-5.937	0	0	0	0.399	1-1	
1	0.5	COMB1	Combination	-8.516	-2.664	0	0	0	2.5492	1-1	
1	1	COMB1	Combination	-8.516	0.609	0	0	0	3.063	1-1	
1	1.5	COMB1	Combination	-8.516	3.881	0	0	0	1.9406	1-1	
1	2	COMB1	Combination	-8.516	7.154	0	0	0	-0.8182	1-1	
1	2	COMB1	Combination	0	-3.273	0	0	0	-0.8182	1-2	
1	2.5	COMB1	Combination	0	-4.41E-14	0	0	0	5.697E-15	1-2	
2	0	COMB1	Combination	142.385	0	0	0	0	0	2	
2	1.60078	COMB1	Combination	142.214	0	0	0	0	0	2	
2	3.20156	COMB1	Combination	142.043	0	0	0	0	0	2	

Record: << < 1 > >> of 10

Add Tables... Done

Demand summary obtained from SAP2000:

Axial load in cable

Max moment in Tee beam @ 1m from support

Max shear in Tee beam @2m from support

$$P = 142.385 \text{ kN}$$

$$M_{\max} = 3.063 \text{ kNm}$$

$$V_{\max} = 7.154 \text{ kN}$$

## Cable

Bolted connection will be used in the structure

bolt size		d,bolt =	22	mm
Strength of bolt		Fub =	825	Mpa
Area of bolt		A,bolt =	380	mm <sup>2</sup>
Grade of steel		Fy =	350	Mpa
		Fu =	450	Mpa
Nominal cable dia		dia =	28.6	
Cross-section area		Ag =	477	mm <sup>2</sup>

### Gross section yielding

Resistance factor		phi =	0.9	
Tensile capacity	$Tr = \phi * Ag * Fy$	Tr =	150	kN
Compare tensile capacity to axial force	$Tr > P$			<b>OK!</b>

## T-Beam

### 1. Flexural check - Lateral Torsional Buckling

Check class	(b/2) / f	Flange =	8.86	<b>Class 2</b>
		Stem =	28.7	<b>Class 3</b>
Class of the section	170 / sqrt(fy)	Limit of class 2 flange and stem =	9.09	
		=	Class 3	

### Perform checks as a laterally unsupported beam.

Equivalent moment factor		w2 =	1	
Length of the beam		L =	2500	mm
Modulus of Elasticity		E =	200000	Mpa
Moment of Inertia in y-direction	from catalogue	Iy =	491000	mm <sup>4</sup>
Shear modulus		G =	77000	Mpa
Torsional St. Venant constant	from catalogue	J =	14600	mm <sup>3</sup>
Torsional warping constant	from catalogue	Cw =	13600000	mm <sup>6</sup>
LTB elastic capacity	$w2 * \sqrt{E * Iy * G * J + Iy * Cw * (\pi * E / L)^2}$	Mu =	13.2	kNm
Yield Moment	from catalogue	Sx =	30300	mm <sup>3</sup>
For doubly symmetric section	$Sx * fy$	My =	10.6	kNm
		0.67 * My =	7.11	kNm
Moment Resistance	$1.15 * \phi * My * (1 - 0.28 * My / Mu)$	phi =	0.9	
Check Mr is less than or equal to phi * My	$\phi * My$	Mr =	8.51	kNm
Compare moment resistance to moment demand	$Mr > Mmax$	phi * My =	9.54	kNm
				<b>OK!</b>

### 2. Shear Check

Check slenderness		h/w =	28.7	
Unstiffened webs		kv =	5.34	
Check $hw < 439 * \sqrt{kv / Fy}$	$439 * \sqrt{kv / Fy}$	Limit of stocky beam =	54.2	<b>Stocky</b>
Critical shear stress	$0.66 * Fy$	Fs =	231	Mpa
Shear Area		Aw =	775.2	mm <sup>2</sup>
Reduction factor		phi =	0.9	
Calculate shear capacity of the beam	$Vr = \phi * Aw * Fs$	Vr =	161.2	kN
Compare shear capacity to shear demand	$Vr > Vmax$			<b>OK!</b>

## Connections from T-beams to HSS

Choose electrodes			E4914	
Tensile strength		Xu =	490	Mpa
Angle between the line of action of force and weld		theta =	0	deg
fillet weld size		w =	6	mm
Length of Weld		L =	100	mm
Throat Length	$\sqrt{2 * w^2}$	Throat =	4.24	mm
Reduction factor		phi w =	0.67	
Area of the fusion face	$w * L * 2$	Am =	1200	mm <sup>2</sup>
Effective area of the throat	$Throat * L * 2$	Aw =	848.53	mm <sup>2</sup>
Strength reduction factor for multi-orientation welds		Mw =	1	
Capacity of Base Metal	$Vr = 0.67 * \phi * w * Am * Fu$	Vr,base =	242.4	kN
Capacity of Weld Metal	$Vr = 0.67 * \phi * w * Aw * Xu * (1 + 0.5 * \sin(\theta)^{1.5}) * Mw$	Vr,weld =	186.6	kN
Compare Base Metal capacity to axial demand	$Vr,base > Vr$			<b>OK!</b>
Compare Weld Metal capacity to axial demand	$Vr,weld > Vr$			<b>OK!</b>

## **Appendix D: Safety Analysis Risk Register**



**Appendix D: Safety Analysis Risk Register**

Risk ID	Description of Hazard	Current Configuration			Preliminary Design			Mitigation Strategy	Main Design Component Added
		Probability (1-5)	Impact (1-5)	Severity (1-25)	Probability (1-5)	Impact (1-5)	Severity (1-25)		
1	Bicyclist and vehicle conflict: Along the block	3	4	12	1	4	4	Risk Reduction	Bike protection buffer
2	Bicyclist and vehicle conflict: Crossing	3	4	12	2	4	8	Risk Reduction	Additional crosswalks, push activated crossing lights, speed tables, speed limit reduction
3	Bicyclist and vehicle conflict: "Dooring"	3	5	15	1	2	2	Risk Avoidance	Lane configuration change, parking lane now inside of bike lane
4	Bicyclist and vehicle conflict: Agronomy Intersection	3	4	12	2	4	8	Risk Reduction	Painted bike lanes
5	Bicyclist and vehicle conflict: Thunderbird Intersection	4	4	16	2	4	8	Risk Reduction	New right turn lanes in both directions reduces risk of right turn collisions with through cyclists
6	Vehicle and vehicle conflict: Eagle Intersection	2	3	6	1	3	3	Risk Reduction	3-way Roundabout
7	Vehicle and vehicle conflict: Stadium Intersection	2	3	6	1	3	3	Risk Reduction	Signalized Intersection
8	Pedestrian and vehicle conflict: Crossing	3	5	15	1	5	5	Risk Reduction	Additional crosswalks, push activated crossing lights, speed tables, speed limit reduction
9	After dark pedestrian safety	3	4	12	2	3	6	Risk Reduction	Increased lighting over sidewalks, additional blue phone

## **Appendix E: Cost Estimates**



C	2	1	4	Utilities pipes			3				1		4	\$745	\$60	\$805
C	2	1	5	Steel			3				1		4	\$745	\$60	\$805
C	2	2		Detailed design drawings	0	0	2	1	9	8	58	78	\$11,870	\$950	\$12,820	
C	2	2	1	Existing and proposed road grading, utilities drawings			1	1	1	1	8	12	\$1,820	\$146	\$1,966	
C	2	2	2	Standard traffic signage drawings			1			1	8	10	\$1,420	\$114	\$1,534	
C	2	2	3						4	3	21	28	\$4,315	\$345	\$4,660	
C	2	2	4	Proposed road alignment and on-street parking drawings					4	3	21	28	\$4,315	\$345	\$4,660	
C	2	3		Deliverables	8	8	12	12	5	4	0	49	\$8,700	\$696	\$9,396	
C	2	3	1	Summary report			8	8	4	2		22	\$4,280	\$342	\$4,622	
C	2	3	2	Design presentation PowerPoint	8	8			1	1		18	\$2,720	\$218	\$2,938	
C	2	3	3	Design presentation video			4	4		1		9	\$1,700	\$136	\$1,836	
C	2	4		IFC drawings	0	0	2	1	5	6	24	38	\$6,400	\$512	\$6,912	
C	2	4	1	Existing and proposed road grading, utilities drawings			1	1	1	1	4	8	\$1,360	\$109	\$1,469	
C	2	4	2	Standard traffic signage drawings			1			1	4	6	\$960	\$77	\$1,037	
C	2	4	3	Canopy structural drawings					2	2	8	12	\$2,040	\$163	\$2,203	
C	2	4	4	Proposed road alignment and on-street parking drawings					2	2	8	12	\$2,040	\$163	\$2,203	
C	2	5		Deliverables	8	8	8	8	8	12	0	52	\$10,720	\$858	\$11,578	
C	2	5	1	Final design report	8	8	8	8	8	12		52	\$10,720	\$858	\$11,578	
				Phase C Total Hours	442	457	122	80	207	45	82	1435	\$225,555	\$18,044	\$243,599	
				Phase A, B and C Total Hours	697	712	247	151	335	97	178	2417	\$384,065	\$30,725	\$414,790	

## Construction Tasks & Cost Estimate

	Types	Labour (per hour)	Equipment (per day)	Material (total)	Subtotal Fees	Contingency	Total Fees
	Rates	\$250	\$300	1		8.00%	
<b>Phase A: Pre-Construction</b>							
A 1	Permitting	0	0	\$2,500	\$2,500	\$200	\$2,700
A 1 1	Development Permit	0	0	\$250	\$250	\$20	\$270
A 1 2	Building Permit	0	0	\$250	\$250	\$20	\$270
A 1 3	Archeology Permit	0	0	\$250	\$250	\$20	\$270
A 1 4	Environmental Permit	0	0	\$250	\$250	\$20	\$270
A 1 5	Plumbing Permit	0	0	\$250	\$250	\$20	\$270
A 1 6	Sprinkler Permit	0	0	\$250	\$250	\$20	\$270
A 1 7	Gas Permit	0	0	\$250	\$250	\$20	\$270
A 1 8	Electrical Permit	0	0	\$250	\$250	\$20	\$270
A 1 9	WorkSafe BC Permit	0	0	\$250	\$250	\$20	\$270
A 1 10	Traffic Permit	0	0	\$250	\$250	\$20	\$270
A 2	Pre-work	56	7	\$0	\$16,100	\$1,288	\$17,388
A 2 1	Surveying	32	4	\$0	\$9,200	\$736	\$9,936
A 2 2	Mobilization	24	3	\$0	\$6,900	\$552	\$7,452
<b>Phase A Total Cost</b>		<b>\$14,000</b>	<b>\$2,100</b>	<b>\$2,500</b>	<b>\$18,600</b>	<b>\$1,488</b>	<b>\$20,088</b>
<b>Phase B: Construction</b>							
B 1	Silva Cells	272	34	\$1,078,560	\$1,156,760	\$92,541	\$1,249,301
B 1 1	Excavating median for Silva Cells	72	9	\$0	\$20,700	\$1,656	\$22,356
B 1 2	Install Silva Cells	160	20	\$918,060	\$964,060	\$77,125	\$1,041,185
B 1 3	Rebuild roadbase on top of Silva Cells	40	5	\$160,500	\$172,000	\$13,760	\$185,760
B 2	North Bound	136	17	\$916,000	\$955,100	\$76,408	\$1,031,508
B 2 1	Re-route utility lines for additional lighting	24	3	\$2,000	\$8,900	\$712	\$9,612
B 2 2	Construct and adjust sidewalk span and curb	56	7	\$752,000	\$768,100	\$61,448	\$829,548
B 2 3	Construct bike lane protection on north bound	56	7	\$162,000	\$178,100	\$14,248	\$192,348
B 3	South Bound	136	17	\$916,000	\$955,100	\$76,408	\$1,031,508
B 3 1	Re-route utility lines for additional lighting	24	3	\$2,000	\$8,900	\$712	\$9,612
B 3 2	Construct and adjust sidewalk span and curb	56	7	\$752,000	\$768,100	\$61,448	\$829,548
B 3 3	Construct bike lane protection on north bound	56	7	\$162,000	\$178,100	\$14,248	\$192,348
B 4	Median	120	15	\$36,700	\$71,200	\$5,696	\$76,896
B 4 1	Replant trees	80	10	\$19,200	\$42,200	\$3,376	\$45,576
B 4 2	Rebuild new curbs	40	5	\$17,500	\$29,000	\$2,320	\$31,320
B 5	Utilities	192	24	\$84,000	\$139,200	\$11,136	\$150,336
B 5 1	Streetlights	120	15	\$20,000	\$54,500	\$4,360	\$58,860
B 5 2	Pedestrian crosswalk Light	32	4	\$8,000	\$17,200	\$1,376	\$18,576
B 5 3	Construct covered bus stops	24	3	\$50,000	\$56,900	\$4,552	\$61,452
B 5 4	UBC Security poles	16	2	\$6,000	\$10,600	\$848	\$11,448
B 6	Lanscaping	256	29	\$26,326	\$99,026	\$7,922	\$106,948
B 6 1	Roundabouts and speed tables	40	5	\$16,851	\$28,351	\$2,268	\$30,619
B 6 2	Traffic singnage and parking meters	40	4	\$3,975	\$15,175	\$1,214	\$16,389
B 6 3	Paint all lanes, crosswalks, bike lanes	16	2	\$500	\$5,100	\$408	\$5,508
B 6 3	Vegetation on sidewalk, median and roundaouts	120	15	\$5,000	\$39,500	\$3,160	\$42,660
B 6 4	Site clean-up	24	3	\$0	\$6,900	\$552	\$7,452
B 6 5	Final inspection and comissioning	16	0	\$0	\$4,000	\$320	\$4,320
B 7	Canopy	56	9	\$80,200	\$96,900	\$7,752	\$104,652
B 7 1	Surveying	8	1	\$0	\$2,300	\$184	\$2,484
B 7 2	Mobilization	8	3	\$0	\$2,900	\$232	\$3,132
B 7 3	Pre-drill for cable anchors	8	1	\$200	\$2,500	\$200	\$2,700
B 7 4	Build canopy structure	16	2	\$80,000	\$84,600	\$6,768	\$91,368
B 7 5	Hang canopy structure on cable	16	2	\$0	\$4,600	\$368	\$4,968
B 7 6	Site clean-up	16	2	\$0	\$4,600	\$368	\$4,968
B 7 7	Inspection	16	0	\$0	\$4,000	\$320	\$4,320
<b>Phase B Total Cost</b>		<b>\$300,000</b>	<b>\$44,100</b>	<b>\$3,137,786</b>	<b>\$3,481,886</b>	<b>\$278,551</b>	<b>\$3,760,437</b>
<b>Phase C: Annual Maintenance</b>							
C 1	Asphalt Pavement	8	1	\$500	\$2,800	\$224	\$3,024
C 2	Drainage	8	0.5	\$0	\$2,150	\$172	\$2,322
C 3	Pavement Marking	8	1	\$200	\$2,500	\$200	\$2,700
C 4	Sidewalk	2	0	\$200	\$700	\$56	\$756
C 5	Signage	2	0	\$50	\$550	\$44	\$594
C 6	Silva Cells	12	1	\$200	\$3,500	\$280	\$3,780
C 7	Street Cleaning	8	1	\$0	\$2,300	\$184	\$2,484
C 8	Street light	2	1	\$100	\$900	\$72	\$972
C 9	Traffic Lights	8	2	\$0	\$2,600	\$208	\$2,808
C 10	Utilities	16	2	\$1,000	\$5,600	\$448	\$6,048
C 11	Vegetation	80	10	\$1,500	\$24,500	\$1,960	\$26,460
<b>Phase C Total Cost</b>		<b>\$38,500</b>	<b>\$5,850</b>	<b>\$3,750</b>	<b>\$48,100</b>	<b>\$3,848</b>	<b>\$51,948</b>
<b>TOTAL COST</b>		<b>\$352,500</b>	<b>\$52,050</b>	<b>\$3,144,036</b>	<b>\$3,548,586</b>	<b>\$283,887</b>	<b>\$3,832,473</b>

## **Appendix F: Construction Schedule**



# **Appendix G: Construction Specifications**



## SPECIFICATIONS FOR REINFORCED CAST-IN-PLACE CONCRETE

The Work shall consist of:

- Supplying of materials and the mixing and placing of reinforced cast-in-place concrete, including placing, vibrating, finishing, and curing
- Supplying, fabricating, constructing, maintaining, and removing temporary works, including formwork
- Heating and cooling concrete, if necessary
- Developing concrete mix design(s) that meets the performance requirements, including trial batches
- The quality control (QC) testing of all materials including: slump, material and air entrained tests for every day concrete is poured or every 75m<sup>3</sup> in accordance with CAN3-23.1 and CAN3-A23.2
  - Strength tests shall include three cylinders, one tested at 7 days, and two tested at 28 days in accordance with CAN3-A23.2

### TEST REFERENCES

All reference standards and related specifications shall be current issue or the latest revision at the date of tender advertisement.

Test References:

- CSA A23.1-1A, Sampling aggregates for use in concrete
- CSA A23.2-4C, Air content of plastic concrete by the pressure method
- CSA A23.2-5C, Slump of concrete
- CSA A23.2-9C, Compressive strength of cylindrical concrete specimens
- CSA A23.2-17C, Temperature of freshly mixed hydraulic cement concrete
- CSA A23.2-1D, Moulds for forming vertical concrete test cylinders

### MATERIALS

#### *Fine Aggregate*

Fine aggregate shall meet the grading requirements of CSA A23.9.1 Clause 4.2.3.3 and meet the grading limits of Table 10 in the same reference

#### *Coarse Aggregate*

The maximum nominal size of coarse aggregate shall be 20 mm and meet the grading requirements of CSA A23.1 Clause 4.2.3.4, and meet the grading limits for Table 11. Coarse aggregate shall be uniformly graded and not more than 1% shall pass a 75 µm sieve.

#### *Cementitious Materials*

Cementitious materials shall conform to the requirements of CSA A23.1 Clause 4.2.1 and shall be free from lumps. Normal portland cement, Type GU (Table 6 in the same reference)

#### *Water*

Water to be used for mixing and curing concrete or grout and saturating the substrate shall be potable, shall conform to the requirements of CSA A23.1 Clause 4.2.2 and shall be free of oil, alkali, acidic, organic materials, or deleterious substances.

#### *Formwork*

Forms for exposed surfaces shall be made of good quality plywood in "like-new" condition and uniform in thickness. Construction for formwork generally must conform to the requirements of CSA A23.1 Clause 6.5.3.

### CONSTRUCTION METHOD

#### *Mixing Concrete*

All concrete shall be mixed thoroughly until it is uniform in appearance, with all ingredients uniformly distributed. In no case shall the mixing time per batch be less than one minute for mixers of one cubic metre capacity or less. The "batch" is considered as the quantity of concrete inside the mixer. This figure shall be increased by 15 seconds for each additional half cubic metre capacity or part thereof. The mixing period shall be measured from the time all materials are in the mixer drum.

#### *Time of Hauling*

The maximum time allowed for all types of concrete to be delivered to the site of the Work, including the time required to discharge, shall not exceed 90 minutes after batching. Batching of all types of concrete is considered to occur when any of the mix ingredients are introduced into the mixer, regardless of whether or not the mixer is revolving. For concrete that includes silica fume, this requirement is reduced to 60 minutes.

#### *Falsework and Formwork*

The design, fabrication, erection, and use of concrete formwork shall conform to the requirements CSA A23.1 and CSA S269.1. All forms shall be oiled or otherwise treated to facilitate stripping.

### COLD WEATHER PRECAUTIONS

#### *General*

When the ambient temperature falls below 5°C or when there is a probability of it falling below 5°C within 24 hours of placing the concrete, the Contractor shall make provisions for heating the water, aggregates and freshly deposited concrete.

#### *Aggregates*

Aggregates shall be heated to a temperature of not more than 65°C. For concrete containing silica fume, the aggregate shall not be heated to more than 40°C. The heating apparatus and the housing for the aggregates shall be sufficient to heat the aggregates uniformly without the possibility of the occurrence of hot spots which may burn the materials.

#### *Water*

The water shall be heated to a temperature of not more than 65°C. For concrete containing silica fume, the water shall not be heated to more than 40°C.

### Concrete

The temperature of the mixed concrete shall not be less than 15°C and not more than 25°C at the time of placing in the forms. Temperature requirements for concrete containing silica fume shall be between 10°C and 18°C at the time of placing in the forms. Sufficient stand-by heating equipment must be available to allow for any sudden drop in outside temperatures and any breakdowns that may occur in the equipment.

### Curing Requirements

Water curing of concrete shall be terminated at least 12 hours before the end of the protection period during periods of freezing weather. The curing compound shall be water based membrane forming and of a type approved by the Engineer. It shall conform to the requirements of ASTM C171 and be applied as directed by the Manufacturer. The rate of each application shall not be less than the rate specified by the Manufacturer of the compound. If rain falls on the newly coated concrete before the film has dried sufficiently to resist damage, or if the film is damaged in any other manner during the curing period, a new coat of solution shall be applied to the affected portions equal in curing value to that specified above.

### Quality Control

Sampling of concrete shall be carried out in accordance with CSA A23.2-1C. Making and curing concrete test cylinders shall be carried out in accordance with CSA A23.2-3C, except that the time for cylinders to reach the testing laboratory shall be between 20 and 48 hours. The test cylinders shall be cast by the Contractor in standard CSA approved moulds.

### Open to Traffic

Sidewalks shall not be opened to traffic until the concrete has attained a minimum compression strength of 75% of the design strength. The Contractor shall be responsible for all costs associated with any additional testing that may be required to satisfy the strength requirement.

## SPECIFICATIONS FOR SUPPLYING AND PLACING BACKFILL

The Work shall consist of:

- Processing, loading, hauling, unloading, placing and compacting backfill material;
- Protecting backfill material from freezing;
- The quality control (QC) testing of all backfill material;

The quantity for supplying and placing backfill may be increased during construction to include the quantity of additional backfill material required because of additional excavation to remove poor soils as determined by the Engineer.

## SUBMITTALS

The Contractor shall provide evidence that scales have been calibrated and certified for the current calendar year by the Weights and Measures Services of the Government of Canada before the scales will be accepted for use. Where the scale has not been calibrated and

certified for the current calendar year, the Engineer may test the scale using procedures specified by Weights and Measures Inspection Services and approve the scale for use on the project.

## MATERIALS

### General

All material used for backfill, including non-granular material, shall meet the following specifications and shall be of a quality acceptable to the Engineer. All backfill material shall be in a thawed state when placing and compacting, and be free from rocks, large or frozen lumps, wood, or other unsuitable material. Backfill material shall not be placed on frozen substrate.

### Types of Backfill

Backfill material shall conform to one of the following types:

#### Type 1 – Granular Backfill (Gradation Requirements)

Sieve Size	% Passing Standard Sieve	
	Granular	Limestone
37.5 mm	100	100
25.0mm	85 – 100	85 – 100
4.75 mm	25 – 80	25 – 80
425 mm	15 – 40	15 – 35
75 µm	8 – 18	0 - 10
Min. Crush Count	15%	-
Max. Los Angeles Abrasion Loss	40%	32%
Max. Shale Content	20%	-

#### Type 2 – Non-Granular Cohesive Material

Non-granular cohesive material shall be highly plastic clay (exhibiting putty-like properties with considerable strength when dry) and non-organic. Material with very high swelling potential such as bentonite clays will not be permitted. When proposed material characteristics are in question, the Engineer may require the Contractor to classify the material using Test Method ASTM D2487 – Classification of Soils for Engineering Purposes. Non-granular cohesive material shall have a minimum Plasticity Index of 40. The non-granular cohesive material shall be free of rocks and stones. When approved by the Engineer, non-granular cohesive material can be substituted with granular material.

## CONSTRUCTION METHODS

### General

The Contractor shall backfill the excavated areas with the specified type of backfill material, unless otherwise directed by the Engineer, to the elevation of the ground surface existing immediately prior to the start of excavation. Backfill material shall be placed in accordance with the Drawings, this Specification and to the satisfaction of the Engineer. Backfill material shall be stockpiled within a suitable area approved by the Engineer. Examples of unsuitable areas include, but are not limited to, the following:

- in the flood plain,
- on the edge of an embankment creating slope stability issues, or
- locations impeding sight lines of the travelling public through or around the site.

During freezing weather, the Contractor shall protect all backfill material from freezing until it is placed to the satisfaction of the Engineer.

### Granular Backfill

The granular backfill shall be placed in layers not to exceed 150 mm in depth and each layer shall be thoroughly compacted by means of packers or mechanical tampers to a relative compaction of not less than 98% Standard Proctor Density for the backfill material at  $\pm 2\%$  optimum moisture content.

### Non-Granular Cohesive Backfill

Cohesive backfill shall be deposited in horizontal layers not exceeding 200 mm in thickness. Every layer shall be tamped in place and well compacted by means of mechanical tampers before the next layer is deposited. In the event that local non-granular cohesive material is deemed unsuitable by the Engineer, the Contractor shall supply non-granular cohesive material meeting the requirements of this specification

## QUALITY MANAGEMENT

### General

The Contractor shall submit a sample of the backfill material and test results fourteen (14) days prior to beginning backfilling operations.

### Quality Control

The Contractor shall be responsible for all quality control testing and shall complete the minimum testing requirements to the specified frequency and test procedures as described in Table 1.

### Quality Assurance

The Engineer, at his/her discretion, may complete random quality assurance testing on all materials incorporated into the Work. The Contractor shall allow the Engineer unhindered access to the materials and shall assist the Engineer in carrying out any sampling or testing, including the provision for necessary traffic control, suitable access and storage. There shall be no charge for materials taken by the Engineer for testing purposes.

## METHOD OF MEASUREMENT

### Type 1 – Granular Backfill

Supplying and placing of granular backfill and culvert gravel will be measured on a mass basis of hauled material. Weigh scale tickets for each truck shall be provided to then Engineer or his representative for verification and approval prior to unloading of backfill material.

### Type 2 – Non-Granular Cohesive Material

Supplying and placing non-granular cohesive material will be paid for on a lump sum basis and no measurement will be taken for this Work.

**TABLE 1  
AGGREGATE TESTING REQUIREMENTS**

TEST	STANDARD REFERENCE	MINIMUM FREQUENCY
Sampling	CSA A23.2-1A ASTM D 75	One test per hour of production or as directed by the Engineer.
Gradation Analysis	CSA A23.2-2A ASTM C 136, C 117	
Soundness of Aggregate	CSA A23.2-9A ASTM C 88	
Density of Aggregate	CSA A23.2-10A ASTM C 29	
Standard Proctor	ASTM D 698	
Sand Equivalent	ASTM D 2419 AASHTO T176	
<b>Coarse Aggregate Only:</b>		
Crush Count	ASTM D 5821	One test per hour of production or as directed by the Engineer.
Shale Content		
Flakiness Index		
Micro-Deval	CSA A23.2-29A ASTM D 6928	One test per material.
Dry-Rodded Unit Weight	ASTM C 29	
Los Angeles Abrasion – Large Size	CSA A23.2-17A	
Los Angeles Abrasion – Small Size	CSA A23.2-16A	
Relative Density and Absorption	CSA A23.2-12A ASTM C 127	At the request of the Contractor.
Base Course Mix Design		
<b>Fine Aggregate Only:</b>		
Organic Impurities	CSA A23.2-7A ASTM C 40	As directed by the Engineer.
Surface Moisture	CSA A23.2-11A ASTM C 70	
Relative Density and Absorption	CSA A23.2-6A ASTM C 128	One test per material.
Material Finer than 75 $\mu$ m	ASTM C 117	One test per sample.

SPECIFICATIONS FOR SUPPLYING AND PAVING ASPHALT ROAD SURFACE

The Work shall consist of:

- Processing, loading, hauling, unloading, placing and compacting asphalt material;
- The quality control (QC) testing of all asphalt material;

Refer to and follow “**City of Vancouver Construction Specifications, Supplementary Specifications Section 32 12 17 – Superpave Hot-Mix Asphalt Concrete Paving**”