

**CIRS Auditorium Ventilation System:  
Adequacy Assessment, Energy Consumption and  
Comfort of the Living Space Provided**

**Prepared by: Marc Tabet**

**University of British Columbia**

**CEEN 596**

**April 30, 2012**

*Disclaimer: "UBC SEEDS provides students with the opportunity to share the findings of their studies, as well as their opinions, conclusions and recommendations with the UBC community. The reader should bear in mind that this is a student project/report and is not an official document of UBC. Furthermore readers should bear in mind that these reports may not reflect the current status of activities at UBC. We urge you to contact the research persons mentioned in a report or the SEEDS Coordinator about the current status of the subject matter of a project/report".*

**CEEN 596 FINAL PROJECT REPORT**

**CIRS Auditorium Ventilation System:  
Adequacy Assessment, Energy Consumption and  
Comfort of the Living Space Provided**



Prepared by: Marc Tabet

April 30, 2012

# Table of Contents

Appendices List.....	4
Preface.....	7
Acknowledgments.....	7
Executive Summary.....	8
a) Project Structure.....	8
b) Important Findings.....	8
I- Introduction.....	11
a) Purpose and Objectives.....	11
b) Background.....	12
II- Systems Description and Control Strategy.....	13
a) The Ventilation System.....	13
General Description .....	13
Characteristic Components.....	14
Available Sensors.....	15
b) The Ventilated System.....	17
General Description .....	17
Space Occupancy/Usage.....	18
Available Sensors.....	20
c) The Control Strategy.....	22
III- Data and Methodology.....	24
a) Experimentation Planning.....	24
Table 09: Experimentation Protocol.....	25
Table 10: Experimentation Protocol Continued.....	26
b) Ventilation Rates and Air Change.....	27
Ventilation.....	27
Air Change Assessment Using The CO2 Concentration Equilibrium Point Methodology.....	28
Air Change Assessment Using a Tracer Gas Methodology .....	28
c) Energy Consumption.....	30
The Fans.....	30
Heating of the Air.....	30
Heat Recovery.....	31
d) Air Quality Assessment.....	32
Volatile Organic Compounds Concentration [VOCs]:.....	32
Carbon Dioxide Concentration [CO2]:.....	34
e) Thermal Comfort Assessment .....	35
IV- Data Interpretation and Analysis – Results.....	36
a) Experimentation Outcome: Actual Occurrence and Obstacles Encountered.....	36
b) Ventilation Rates Assessment Results.....	38
Ventilation.....	38
Air Change Assessment Using The CO2 Concentration Equilibrium Point Methodology.....	40
Air Change Assessment Using a Tracer Gas Decay Methodology .....	41
c) Energy Consumption.....	46

The Fans.....	53
Heating of the Air.....	53
Heat Recovery.....	53
d) Air Quality Assessment Results and Limitations.....	54
Volatile Organic Compounds Concentration [VOCs].....	54
Carbon Dioxide Concentration [CO2] .....	58
e) Thermal Comfort Assessment Results and Limitations.....	62
V- Results Integration, Energy Savings and Optimization Recommendations.....	65
VI- Conclusion.....	71
VII- Project Significance.....	71
VIII- References.....	72
IX- Appendices .....	73

## Index of Tables

Table 00: Acronyms and Abbreviations.....	6
.....	6
Table 01: List of the AHU2 Characteristic Components.....	14
Table 02: List of The AHU of the Auditorium Sensors Used to Extract Data For This Study.....	15
Table 03: List of The AHU of the Auditorium Sensors Not Used to Extract Data For This Study.....	16
Table 04: CIRS Auditorium Class Schedule and Expected Occupancy.....	19
Table 05: Auditorium Maximum Fresh Air Supply Requirements and Needs.....	20
Table 06: Auditorium Average Fresh Air Supply Requirements and Needs.....	20
Table 07: List of Auditorium Sensors Used to Extract Data For This Study.....	21
Table 08: List of Auditorium Sensors Not Used to Extract Data For This Study.....	21
Table 09: Experimentation Protocol.....	25
Table 10: Experimentation Protocol Continued.....	26
Table 11: Experimentation Placement, Protocol and Obstacles Encountered.....	37
Table 12: OA, EA, SA Manual Measurements Results.....	39
Table 13: Outside Air Flow Intake Assessment Using Two Different Techniques.....	39
Table 14: CO2 Concentration Equilibrium Methodology for OA Flow Assessment Results.....	40
Table 15: CO2 purchase for the Tracer Gas Decay Methodology Costs .....	41
Table 16: ACR Assessment Results through [CO2] Decay Monitoring Methodology.....	45
Table 17: Numerical Energy Absolute Value Analysis for Test Period 2.....	48
Table 18: Numerical Energy Deviation Percentage From Average Analysis for Test Period 2.....	49
Table 19: Numerical Absolute VOC Concentrations Level Analysis For Test Period 2.....	54
Table 20: Numerical Absolute CO2 Concentrations Level Analysis For Test Period 2.....	60
Table 21: Thermal Comfort Assessment Over Testing Period .....	62
Table 22: Thermal Comfort Uniformity Within The Auditorium Analysis.....	63
Table 23: Experiments Outcome Summary 1.....	68
Table 24: Experiments Outcome Summary 2.....	69

## List of Figures

Figure 01: Auditorium Ventilation System BMS Screen-shot - Sensors Layout.....	17
Figure 02: Auditorium BMS Screen-shot - Sensors Layout.....	22
Figure 03: Thermodynamic CV 1st Law Analysis on Supply Air .....	30
Figure 04: Thermodynamic Model of The Heat Recovery Unit.....	31
Figure 05a: Detectable VOCs.....	33
Figure 05b: Correlation of CO2 and VOCs Concentrations as Measured in a Typical conference Room.	34
Figure 06: ASHRAE Standard 55-2004 Comfort Psychometric Chart.....	35
Figure 07: CO2 Concentration Decay Experiment Explained.....	42
Figure 08: Overview of CO2 Concentration Decay Over Experimentation Period.....	43
Figure 09: Forced CO2 Concentration Decay Monitoring Over 10min and 30min Period.....	44
Figure 10: Natural CO2 Concentration Decay Monitoring Over a 45min Period.....	44
Figure 11: Stratification of the Air in the Auditorium Explanation .....	46
Figure 12: Typical AHU2's Energy Consumption Behavior – Reference Experiment March 5.....	47
Figure 13: Typical Auditorium Environment VOCs Concentration Behavior – Ref. Exp. March 5.....	54
Figure 14: Typical Auditorium Environment CO2 Concentration Behavior – Ref. Exp. March 5.....	59
Figure 15: CIRS Energy System Diagram.....	65
Figure 16: Ventilation System Energy Diagram.....	66

## Appendices List

- Appendix\_1\_Flow\_Meter\_User\_Manual\_ABB\_ACG550\_PCR.pdf
- Appendix\_2\_VOC\_Sensor\_Greystone\_Air\_300.pdf
- Appendix\_3\_Honeywell\_Temperature\_C70xx\_sensors.pdf
- Appendix\_4\_Honeywell\_CO2\_sensor\_C7632.pdf
- Appendix\_5\_Honeywell\_Humidity\_H763x.pdf
- Appendix\_6\_Honeywell\_Press\_P7640.pdf
- Appendix\_7\_UltraTech\_Air\_Flow\_Stations\_EDPTjr\_OM.pdf
- Appendix\_8\_AHU\_Specifications.pdf
- Appendix\_10-Honeywell\_TR21\_TR24\_temp\_sensor.pdf
- Appendix\_12-AHU2\_Sequence\_of\_Operation.pdf
- Appendix\_13\_Image\_Auditorium.jpg
- Appendix\_14\_Image\_Auditorium.jpg
- Appendix\_15\_Image\_Auditorium.jpg
- Appendix\_16\_Image\_Auditorium.jpg
- Appendix\_17\_Image\_Auditorium.jpg
- Appendix\_18\_Image\_Auditorium.jpg
- Appendix\_19\_Image\_Auditorium.jpg
- Appendix\_20\_Image\_Auditorium.jpg
- Appendix\_21\_Image\_Auditorium.jpg
- Appendix\_22\_Image\_Auditorium.jpg
- Appendix\_23\_Image\_Auditorium.jpg
- Appendix\_24\_A-101 - Floor Plan Level Ground.pdf

- Appendix\_25\_Understanding\_How\_to\_Calculate\_Enthalpy\_of\_Moist\_Air.pdf
- Appendix\_26\_Experiment\_1\_Test\_Period\_1\_9am\_to\_4pm\_Results.pdf
- Appendix\_27\_Experiment\_1\_Test\_Period\_1\_All\_Day\_Results.pdf
- Appendix\_28\_Experiment\_2\_Test\_Period\_1\_9am\_to\_4pm\_Results.pdf
- Appendix\_29\_Experiment\_2\_Test\_Period\_1\_All\_Day\_Results.pdf
- Appendix\_30\_Experiment\_3\_Test\_Period\_1\_9am\_to\_4pm\_Results.pdf
- Appendix\_31\_Experiment\_3\_Test\_Period\_1\_All\_Day\_Results.pdf
- Appendix\_32\_Experiment\_4\_Test\_Period\_1\_9am\_to\_4pm\_Results.pdf
- Appendix\_33\_Experiment\_4\_Test\_Period\_1\_All\_Day\_Results.pdf
- Appendix\_34\_Experiment\_5\_Test\_Period\_1\_9am\_to\_4pm\_Results.pdf
- Appendix\_35\_Experiment\_5\_Test\_Period\_1\_All\_Day\_Results.pdf
- Appendix\_36\_Experiment\_6\_Test\_Period\_1\_9am\_to\_4pm\_Results.pdf
- Appendix\_37\_Experiment\_6\_Test\_Period\_1\_All\_Day\_Results.pdf
- Appendix\_38\_Experiment\_7\_Test\_Period\_1\_9am\_to\_4pm\_Results.pdf
- Appendix\_39\_Experiment\_7\_Test\_Period\_1\_All\_Day\_Results.pdf
- Appendix\_40\_Experiments\_Comparison\_Absolute\_Trial\_1.pdf
- Appendix\_41\_Experiments\_Comparison\_Relative\_Trial\_1.pdf
- Appendix\_42\_Experiment\_1\_Test\_Period\_2\_Results\_9am\_to\_4pm.pdf
- Appendix\_43\_Experiment\_1\_Test\_Period\_2\_Results\_All\_Day.pdf
- Appendix\_44\_Experiment\_2\_Test\_Period\_2\_Results\_9am\_to\_4pm.pdf
- Appendix\_45\_Experiment\_2\_Test\_Period\_2\_Results\_All\_Day.pdf
- Appendix\_46\_Experiment\_3\_Test\_Period\_2\_Results\_9am\_to\_4pm.pdf
- Appendix\_47\_Experiment\_3\_Test\_Period\_2\_Results\_All\_Day.pdf
- Appendix\_48\_Experiment\_4\_Test\_Period\_2\_Results\_9am\_to\_4pm.pdf
- Appendix\_49\_Experiment\_4\_Test\_Period\_2\_Results\_All\_Day.pdf
- Appendix\_50\_Experiment\_5\_Test\_Period\_2\_Results\_9am\_to\_4pm.pdf
- Appendix\_51\_Experiment\_5\_Test\_Period\_2\_Results\_All\_Day.pdf
- Appendix\_52\_Experiment\_6\_Test\_Period\_2\_Results\_9am\_to\_4pm.pdf
- Appendix\_53\_Experiment\_6\_Test\_Period\_2\_Results\_All\_Day.pdf
- Appendix\_54\_Experiment\_7\_Test\_Period\_2\_Results\_9am\_to\_4pm.pdf
- Appendix\_55\_Experiment\_7\_Test\_Period\_2\_Results\_All\_Day.pdf
- Appendix\_56\_Experiments\_Comparison\_Absolute\_Trial\_2.pdf
- Appendix\_57\_Experiments\_Comparison\_Relative\_Trial\_2.pdf
- Appendix\_58\_Automatic\_Day\_1\_Results\_9am\_to\_4pm.pdf
- Appendix\_59\_Automatic\_Day\_1\_Results\_All\_Day.pdf
- Appendix\_60\_Automatic\_Day\_2\_Results\_9am\_to\_4pm.pdf
- Appendix\_61\_Automatic\_Day\_2\_Results\_All\_Day.pdf
- Appendix\_62\_Automatic\_Day\_3\_Results\_9am\_to\_4pm.pdf
- Appendix\_63\_Automatic\_Day\_3\_Results\_All\_Day.pdf
- Appendix\_64\_Automatic\_Day\_4\_Results\_9am\_to\_4pm.pdf
- Appendix\_65\_Automatic\_Day\_4\_Results\_All\_Day.pdf
- Appendix\_66\_Automatic\_Day\_5\_Results\_9am\_to\_4pm.pdf
- Appendix\_67\_Automatic\_Day\_5\_Results\_All\_Day.pdf
- Appendix\_68\_Auto\_Day\_Results\_2\_Comparison.pdf

Table of Abbreviations and Acronyms	
Abbreviation	Unabridged Expression
[CO <sub>2</sub> ]	Carbon Dioxide Concentration
[VOCs]	Volatile Organic Compounds Concentration
AHU	Air Handling Unit
ASHRAE	American Society of Heating, Refrigeration and Air Conditioning Engineers
BASE	Building Assessment Survey and Evaluation
C	Concentration
CIRS	Center for Interactive Research on Sustainability
CO <sub>2</sub>	Carbon Dioxide
D	Impeller Diameter
EA	Exhaust Air
EOS	Earth and Ocean Sciences
Gp	CO <sub>2</sub> Emission Volume Flow Rate Per Person
h	Enthalpy
HC	Heating Coil
HCP	Heating Coil Pump
HRU	Heat Recovery Unit
Hz	Hertz
I	Current
Kg	Kilograms
l	Slope of Linear Regression Line
L	Liter(s)
m	mass
m	Mass Flow Rate
MA	Mixed Air
NE	North-East
NW	North-West
OA	Outside Air
P	Supply Pressure
PF	Power Factor
ppm	parts per million
Q	Flow Rate
Q (in schematics)	Heat
RA	Return Air
RF	Return Fan
RH	Relative Humidity
s	seconds
SA	Supply Air
SBS	Sick Building Syndrome
SE	South-East
SF	Supply Fan
SW	South-West
T	Temperature
T	time
V	Voltage (Contextual)
V	Volume (Contextual)
VFD	Variable Frequency Drive
VOCs	Volatile Organic Compounds
ρ	Density
x (in certain equations)	Quality

Table 00: Acronyms and Abbreviations

## Preface

In the context of my Masters in Clean Energy Engineering Program at UBC I was assigned the final project of assessing the ventilation system of the auditorium of one of the buildings on campus. The assessment is concerned with the livability of the environment presented by this auditorium and how it relates to the energy consumption of the ventilation system supporting it. Energy conservation and demand side management are among our most important tasks and objectives as clean energy engineers. A ventilation system can consume around 1/3 of a building's total energy needs and seeking its optimization falls directly in the category of energy conservation.

The building concerned with the project is the Center for Interactive Research on Sustainability (CIRS), I am honored to be granted the opportunity to work on one of the most sustainable and innovative buildings ever created in North America.

The main problematic that arises is that, very often, changes implemented in a ventilation system leading to energy savings are made at the expense of the livability of the environment being served by this system. The reason for this is that energy is invested through the system into deviating the occupied space conditions away from the ambient ones (often unfavorable for comfortable living, occupation and activity) to make it more adequate for living. Investing less energy into the process often results in ambient conditions being counteracted with less intensity.

The project is very instructive on many levels and is representative of professional engineering work; it also covers many type of activities: data gathering, in site visits, coordination with other professionals, the use of a BMS, the gathering of knowledge to interpret the data, the development of tools (excel macros) to process the data. It gives a good insight on the behavior of a ventilation systems in terms of energy consumption and maintaining the comfort of the living space, it also gives good understanding of building living space management: what happens in the background of a building we use that we are most of the time not aware of.

The project is definitely relevant to the objectives of this masters in terms of learning since it is a direct exposure to energy management. It clearly highlights the advantages and the potential of having so many sensors on site among which monitoring and optimization.

## Acknowledgments

I am extremely grateful towards all the amazing people, academics, staff and supervisors that have provided me with invaluable support and guidance during this project: Scott Yonkmann, Jen Crothers, Carla Dasilva, Brenda Sawada, Alberto Cayuela, Eric Mazzi, Steven Rogak and all the others I might have unwillingly failed to mention.



## Executive Summary

The project has several purposes that will be further elaborated along the report, but mainly, providing an insight on an innovative ventilation system and the usefulness of the numerous sensors/controls it is equipped with; as well as to shed the light on how these can be used to reduce the system's energy consumption while not hindering its adequate function.

### a) Project Structure

The first part of the project consists of thoroughly understanding and describing the system (both ventilated and ventilating) through the different sections provided and supported by numerous appendices. The second part investigates the theory behind comfortable living conditions at two levels (thermal comfort and air quality) and how it can be measured through the available sensors. The third part aims at establishing a relevant testing protocol that will make use of the different controls available in the system to try to achieve some energy savings through behavior modification. The fourth part consists in executing the protocol and extracting the data from the relevant sensors. The fifth part consists of processing and analyzing the data in order to establish a relation between energy consumption and comfortable living conditions provided by the ventilation system using different tools and engineering knowledge. Finally, the different parts of the analysis are integrated in order to support suggestions about potential energy measures. Along the project a set of 6 experiments compared to a reference day were performed and their results analyzed.

### b) Important Findings

- In comparison to other commonly found building's ventilation system the availability and variety of the sensors can be deemed excellent.
- A relative humidity and temperature sensors should be installed at the exit of AHU1.
- A relative humidity sensor should be installed at the level of the 1<sup>st</sup> filter of the Heat Recovery Unit.
- To Date The OA and EA Flow Sensors are Uncalibrated, Insure the devices are properly calibrated in the future.
- The heating valve position sensor does not seem to be reliable an investigations is recommended to shed light on the matter.
- Following Ashrae 62 Standards, the outside air requirement for a maximum occupancy of the auditorium is calculated to be 3408 L/s.
- Three methodologies were relied upon to verify if this criterion is met (*Manual Measurements* in substitution for the OA sensor - *CO2 Equilibrium Methodology* - *CO2 Decay Monitoring Methodology*).

- The Manual Measurements were not reliable due to the lack of ability to perform measurements according to standardized protocols.
- The CO<sub>2</sub> decay monitoring methodology was not reliable due to the very short period of time of testing however both the methodology and the results were presented as reference for potential other studies.
- The CO<sub>2</sub> equilibrium despite inconsistencies for two experiments showed that the Fresh air intake requirement criterion is met.
- When it comes to comparing the experiments to a normal day of operation such as on March 19 it is noticed that in all experiments during which energy saving measures were implemented, the ventilation system's average power consumption is indeed lower.
- The energy recovered from the EA of AHU2 at the level of the HRU could not be calculated due to the absence of a proper real time monitoring of the EA flow (uncalibrated sensor).
- *No standards have been set for VOCs in non industrial settings.* In fact, a recent review concluded that no scientifically valid guidance could be given with respect to indoor TVOC levels. There are, however, possible benefits to be derived from keeping exposures to airborne contaminants “As Low As Reasonably Achievable.”
- The VOCs concentration seems unexpectedly independent of the auditorium occupation level during the testing period. An investigation should be made to explain the situation.
- Critical Levels of VOCs concentration are never reached when the auditorium is occupied.
- VOCs levels are pretty stable along the day, no significant fluctuations are recorded.
- A VOCs concentration surge is recorded everyday during the start-up of the ventilation system that last for one to two hours. Potential exposure of students to above the critical limit of VOC concentration can occur at this moment but is not necessarily dangerous/problematic.
- The critical CO<sub>2</sub> concentration for the auditorium is considered to be 1000 ppm. This arbitrary value comes from the wide belief in building management that this is a common practice supported by Ashrae. The CO<sub>2</sub> level of 1000 is a guideline for comfort acceptability, not a ceiling value for air quality, it is used as a surrogate for odor causing compounds from human activity that may not be acceptable for human comfort.

- A narrow definition of thermal comfort was adopted, an analysis based on this criterion shows that thermal comfort is achieved within the auditorium (despite slight deviations) but overall it would be recommended to increase the temperature set point by 1 degree Celsius.
- The integration of all the results obtained in this study show that, a lower energy consumption is achieved, when implementing measures through an override of the control system (such as OA intake reduction or circulation flow reduction), in comparison to a normal day of operation. Some of these measures do not affect significantly the livability of the environment which proves that there is still margin of optimizing the ventilation system operation.
- Tweaking the control algorithm of the ventilation system in a way to obtain 10% less circulation flow is recommended. This measure will not hinder the livability/comfort of the auditorium's environment.

## I- Introduction

### *a) Purpose and Objectives*

The purpose of this study is to monitor the state of several parameters characterizing the ventilation system of the CIRS Auditorium, process the data gathered, and analyze it in order to have a better understanding of its behavior and associated energy usage. This would be helpful in providing insights into ventilation needs for auditoriums which are a common application and help develop a protocol for future investigations of the ventilation throughout the CIRS building.

The characteristics of the ventilation includes flow rates of intake, outlet and return air and the achieved air renewal bounded by certain thermal comfort and air quality requirements. The implications of comfortable (thermal and air quality) living space can be infinite and the thorough analysis of each of its contributing factors could encompass a series of research and final projects. This is the reason why, in the scope of this study, a less thorough definition of what is implied by thermal comfort as well as air quality will be considered. The metrics involved and their interpretation will be significant while not absolute, they include: temperature, VOCs and CO<sub>2</sub> concentrations, relative humidity and air renewal rate. When it comes to assessing the ventilation system: air flow rates (intake, outlet and return) and motors fan power consumption will be monitored. Those will be obtained by data extraction from the already installed sensors.

The objectives of this CEEN 596 project will include:

- A description of the CIRS Auditorium System: size, layout, ventilation system, in-situ instruments, occupancy/usage.
- A monitoring of the parameters of interest for both the ventilation system and living space provided over a 5 days period during which the former is set on automatic mode.
- A series of experiments consisting of overriding the automatic control of the ventilation system parameters such as flow rate and fresh air intake in order to gain an understanding of the ventilation system behavior in the given operating conditions (occupancy and environment).
- An estimate of the ventilation energy usage.
- An hourly data collection during two distinctive 7 days period in the week of February 6 and March 5.
- An air change assessment using a tracer gas methodology (CO<sub>2</sub>).
- An evaluation of the thermal comfort (constrained definition) achieved .
- An evaluation of the indoor air quality (constrained definition) achieved.

## *b) Background*

The CIRS building in the UBC campus is one of the greenest building on earth. It encompasses a series of new technologies to efficiently provide a comfortable and functional living space for its occupant thus reducing its impact on the environment with which it interacts. The building was designed in accordance with the highest standards of sustainability. It is meant to be a living laboratory, in a way that, it will provide through the different sensors it presents an extensive amount of data that will enable those interested to understand what are the energy implications of providing a sustainable and functional living space in the buildings of tomorrow. In order to achieve its design purpose the building should perform well through all of its systems, among which the ventilation system, that contribute to creating this comfortable living space. “Actually, people spend over 80% of their time indoor. In most circumstances, poor ventilation is the dominant factor in causing poor indoor air quality” [1].

Rapidly increasing energy prices, concerns about resource depletion and climate change, and calls for national energy self-sufficiency have concentrated people’s minds on the role energy plays in life [2]. In the future, more buildings will have to be constructed to accommodate the world's growing population. This has to be done with the limited availability of resources in mind. However, since old buildings are only replaced with new ones at a very slow rate, it is important to consider how energy is used in the already existing buildings. It is estimated that buildings could save 10-15 percent on their energy bills if they witness energy efficiency improvements [2]. Baring in mind that buildings account for more than 40% of all the energy consumption in most countries [3], all what have been said reveals the importance of the efficient use of energy in buildings and the information the CIRS will provide with this regard.

The living space provided by a room is affected by its level of occupancy and its interaction with the environment. A ventilation system is aimed at replacing the progressively altered air in the room with fresh air (adequate in both temperature and composition). The higher the occupancy of the living space and its thermodynamic contrast with the environment the more artificially altered air has to be forced in. This requires more energy input into both the modification of the thermodynamic state of the air (cooling/heating, humidifying/dehumidifying) and the channeling of a greater quantity of it into the room. To which extent this replacement has to be done is dictated by the conditions of thermal comfort and air quality aimed to be achieved in the room. This represents the relationship between a ventilation system and the building energy usage. A mechanical ventilation system, in a conventional building, consumes 1/3 to 1/2 of all its energy requirements, and a significant portion of this energy is used for conditioning outdoor air [4,5] which justifies any interest that would be granted to it in the context of this Masters In Clean Energy Program; specially in the case of the CIRS where the ventilation is aimed to be in accordance with the highest sustainability standards. By sustainable living space it is partially implied comfort provided at the least energy cost. This is mostly what is aimed at being assessed through the completion of this project. Given the complexity of the building and the time restrictions imposed it was chosen that a “sample living space” provided by the building will be evaluated in the scope of this project.

The auditorium of the CIRS was chosen as the “sample living space” of interest for several reasons:

- It is a system of which boundaries are clearly and physically defined (isolated from the rest of the building).
- Its high occupancy can make the data obtained more relevant since the study is in big part concerned by how the created environment is perceived.
- It represents a significant chunk of the living space provided by the building.
- It has a significant amount of sensors monitoring its state.
- It has a mechanical ventilation (Air handling unit) system for itself.

The study can also be considered a precursor in the assessment of the other parts of the building with regards to ventilation.

## II- Systems Description and Control Strategy

### a) The Ventilation System

#### General Description

The ventilation system of the CIRS auditorium serves *one temperature control zone* through a *single duct* air distribution system; it is referred to as *central single zone system*. Although there might be some ambiguities with regards to this matter, because of the fact that the fans are regulated by VFDs, the system can be regarded as a *constant volume system*. The flow rates were noticed to be constant (SA flow rate is around 3000 L/s) except when VOCs concentration reached critical values, as can be seen on March 21 (Appendices 62 and 63). The speed variation of the fans is mostly required for their start up sequence and to maintain the static pressure within the duct to a desired one. The start up sequence reduces the load on the fan motors by progressively increasing their speed to the desired steady state one. In theory the VFD can be manually controlled in order for the fans to reach any desired RPM. This opportunity is exploited in the experimentation part of this study and can be the source of energy savings. The system comprises a return fan and a *heat recovery system* to preheat the outlet air drawn in with the room exhaust air. The *outdoor air intake control* is regulated through the positioning of the supply, return and outlet dampers which is regulated according to the VOCs and CO<sub>2</sub> concentration in the auditorium. Figure 1 can help the reader visualize the system.

## Characteristic Components

This section gives an overview of the main components that make up the ventilation system and some of their specifications. The purpose of it is to give an insight on the design intents as well as the size of the system which would potentially enable a comparison to other similar systems in other buildings if needed.

List of the AHU2 Characteristic Components (Appendix 8, Appendix 9)		
Components	Characteristics	Quantification
Supply Fan	Qty - Max Air-FLow, BHP, Diameter	3X - 4945, 12.64, 20"
Return Fan	Qty - Max Air-FLow, BHP, Diameter	3X – 10000,2.18, 16"
Supply Fan Motor	Qty - Voltage, Phases, Capacity	3X - 575V, 3phases, 5HP
Return Fan Motor	Qty - Voltage, Phases, Capacity	3X - 575V, 3phases, 5HP
Filter 1	Type, Quantity, Surface Area	Pleated, 8, 24" x 24"
Filter 2	Type, Quantity, Surface Area	Air-screen 2300 electronic, 8, 4 24"x24" & 4 24"x12"
OA Damper	Number of Blades, Surface Area, Parallel/Opposed	7 Blades, 1881 square inches, Parallel blade
MA Damper	Number of Blades, Surface Area, Parallel/Opposed	8 Blades,1677 square inces, Opposed blade
EA Damper	Number of Blades, Surface Area, Parallel/Opposed	8 Blades,1677 square inces, Opposed blade
Cooling Coil	Max Coolant Flow Rate, Surface Area, Coolant Fluid Temperature...	90.5GPM, 30sqft, 50F...
Heating Coil	Max Heating Fluid Flow Rate, Surface Area, Fluid Temperature...	116.5GPM, 30sqft, 110F...
Duct-work	Section Area 1, Length 1, Section Area 2, Length 2...	Appendix 9
Air Outlets	Numbers, Types, Surface Area	Appendix 9
Air Inlets	Numbers, Types, Surface Area	Appendix 9

**Table 01: List of the AHU2 Characteristic Components**

## Available Sensors

The ventilation system of the CIRS auditorium is equipped with a variety of sensors monitoring the state of its variables of which some are directly measurable (such as temperature) and some are derived (such as flow rate or energy consumption). In comparison to other commonly found building's ventilation system the availability and variety of the sensors can be deemed excellent. This greatly facilitates any study aimed at understanding the behavior of the system, the process of troubleshooting any defect in the context of a maintenance procedure or simply insuring a proper functioning of the system. The information provided by those sensors is , with a few exceptions, enough (if no obstacles are encountered, such as misconfiguration or defects) to support the completion of the objectives of this project without requiring additional monitoring through manual measurements. However this information is not “ultimate”in a way that, in the context of other studies, other measurements might be needed. For example such as in the context of an air-balance study, a noise adequacy study or a vibration study etc...

List of The Auditorium AHU Sensors Used For Data Extraction			
Sensor	Brand	Model Reference	Additional Info
OA Flow Rate	UltraTech	EDPTjr	Appendix 7
MA Temperature	Honeywell	C7041R2018	Appendix 3
SF Speed	ABB	ACH550-VDR-017A-6+F267	Appendix 1
SF Current Consumption	ABB	ACH550-VDR-017A-6+F267	Appendix 1
SA Temperature	Honeywell	C7041R2003	Appendix 3
SA Relative Humidity	Honeywell	H7635B2018	Appendix 5
SA Flow Rate	UltraTech	EDPTjr	Contact Manufacturer
SA Static Pressure	Honeywell	P7640B1032	Appendix 6
SA Pressure	Honeywell	P7640B1032	Appendix 6
RF Speed	ABB	ACH550-VDR-017A-6+F267	Appendix 1
RF Current Consumption	ABB	ACH550-VDR-017A-6+F267	Appendix 1
RA CO2 Concentration	Honeywell	C7632B	Appendix 4
RA VOC Concentration*	Greystone	Air	Appendix 2
RA Relative Humidity	Honeywell	H7635B2018	Appendix 5
RA Temperature	Honeywell	C7041R2003	Appendix 3
EA Flow Rate	UltraTech	EDPTjr	Appendix 7
EA Temperature	Honeywell	C7041R2003	Appendix 3

**Table 02: List of The AHU of the Auditorium Sensors Used to Extract Data For This Study**

\* More information with regards to the sensor's operating principle, resolution and detectable compounds is given in the VOCs Concentration related sections



List of The Auditorium AHU Sensors Not Used For Data Extraction		
Sensor	Sensor	Sensor
Heating Valve Opening	SF (Supply Fan) Speed	OA Damper Opening
Heating Pump Control	SA Static Pressure	RA Damper Opening
Heating Pump Current Consumption	RF (Return Fan) Speed	EA Damper Opening
Cooling Valve Control	RF Current Consumption	SA Pressure

**Table 03: List of The AHU of the Auditorium Sensors Not Used to Extract Data For This Study**

Note: An example on the limitations of this selection of sensors was encountered while performing this study. One can deem useful the knowledge of energy (from each of the two air handling units ) being exhausted prior to recovery which is of interest. To do so, an as can be seen in the heat recovery section of this report, a knowledge of the flow rate, temperature and relative humidity is needed for each of the relevant air streams. While there is a sensor in the system to quantify the amount of energy extracted from the combined streams of the two air handling units of the building some sensors are lacking thus preventing the derivation of the amount of energy escaping from the air handler one or the amount of energy extracted from each stream individually. To counter this problem, two relative humidity and temperature sensors were installed one at the level the the air handler one exhaust stream and the other at the level of the mixing of the two streams.

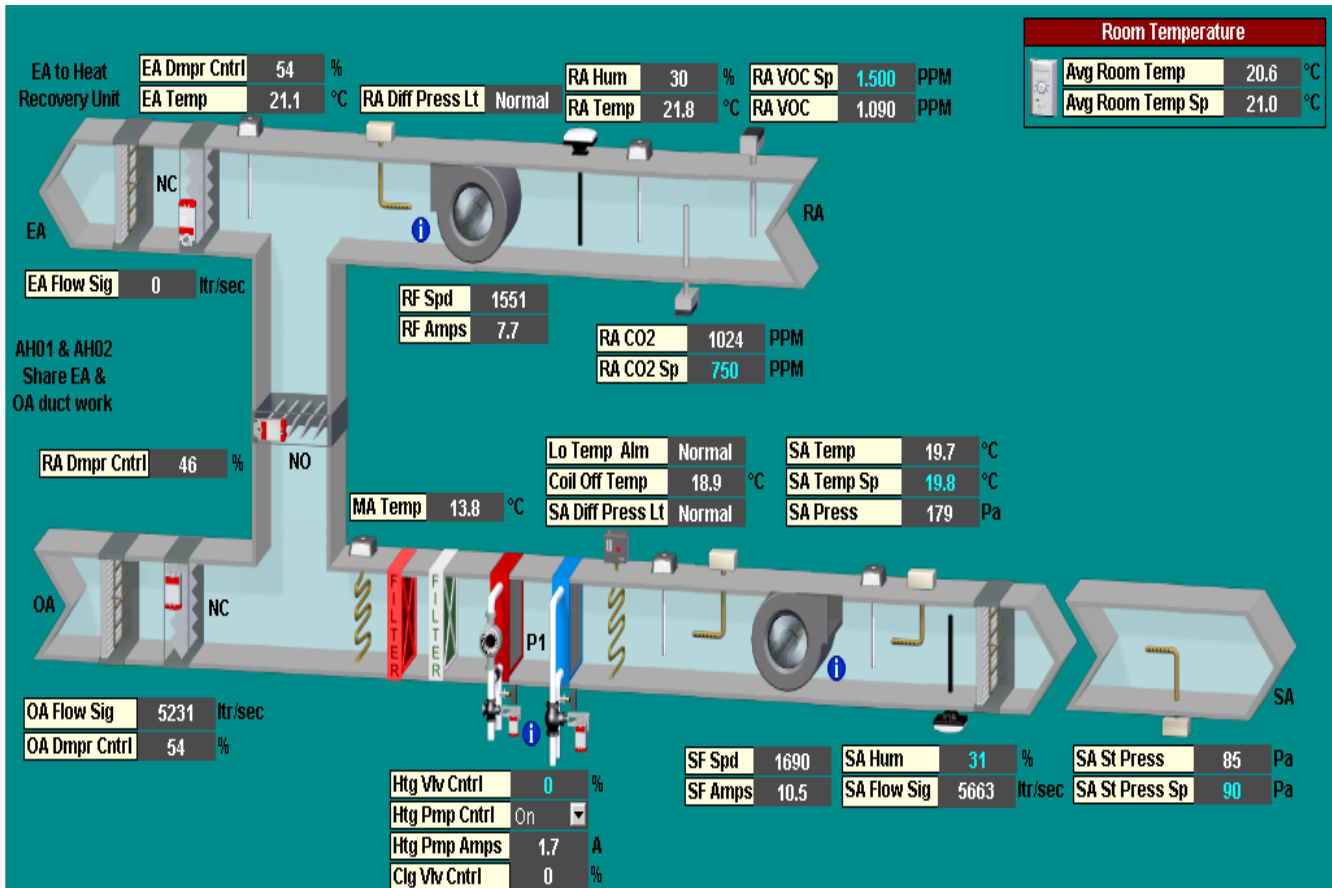

Figure 01: Auditorium Ventilation System BMS Screen-shot - Sensors Layout

**b) The Ventilated System**

**General Description**

The ventilated system is an approximately 465m<sup>2</sup> space with 426 seats arranged in successive arc-circles. With an average height roughly measured, the volume is estimated to be around 3240m<sup>3</sup>. Sensors are mounted on the side walls at all corners of the auditorium. The supply of air is mainly directed from East to West: most of the air is supplied by the vents under the seats and at the top back of the auditorium. Most of the return air is channeled from the front through big elevated squared vents. The auditorium present four windows on its roof that open parallel to the ground and prevent rain from leaking in when opened thanks to an ingenious design. Appendices 13 to 24 describe in images and drawings what could hardly be described in words.

## Space Occupancy/Usage

The adequacy of the living space provided by the auditorium through its ventilation system is intricately related to its occupation level. The occupants alter the living space by emitting CO<sub>2</sub>, VOCs and Heat which the ventilation systems permanently tries to keep within reasonable ranges as defined by the relevant standards. How the environment is perceived by the occupants will be dependent on how many occupants there is; and therefore the adequacy of the ventilation system should be assessed for different occupation levels and should be deemed reasonable for all of them. There are more than 4 classes during each working day and usually attended by more than 150 Students. The UBC Classroom Services was contacted to obtain a detailed schedule describing the expected occupancy level of the auditorium during the hours of interest (9am to 4pm during working days). The schedule is presented in Table 04.

CIRS Auditorium Class Schedule/Occupancy						
From	To	Monday	Tuesday	Wednesday	Thursday	Friday
09:00	09:30	PSYC 102 Section 002 Christie, Stella <b>Occupancy:</b> 133		PSYC 102 Section 002 Christie, Stella <b>Occupancy:</b> 133		PSYC 102 Section 002 Christie, Stella <b>Occupancy:</b> 133
09:30	10:00		PSYC 101 Section 007 Rankin, Catherine <b>Occupancy:</b> 255		PSYC 101 Section 007 Rankin, Catherine <b>Occupancy:</b> 255	
10:00	10:30	PSYC 102 Section 003 Christie, Stella <b>Occupancy:</b> 257		PSYC 102 Section 003 Christie, Stella <b>Occupancy:</b> 257		PSYC 102 Section 003 Christie, Stella <b>Occupancy:</b> 257
10:30	11:00					
11:00	11:30	PSYC 208 Section 003 Wehr, Paul <b>Occupancy:</b> 202	PSYC 209A Section 002 Handy, Todd <b>Occupancy:</b> 227	PSYC 208 Section 003 Wehr, Paul <b>Occupancy:</b> 202	PSYC 209A Section 002 Handy, Todd <b>Occupancy:</b> 227	PSYC 208 Section 003 Wehr, Paul <b>Occupancy:</b> 202
11:30	12:00					
12:00	12:30	PSYC 102 Section 004 Paulhus, Delroy <b>Occupancy:</b> 336		PSYC 102 Section 004 Paulhus, Delroy <b>Occupancy:</b> 336		PSYC 102 Section 004 Paulhus, Delroy <b>Occupancy:</b> 336
12:30	13:00		ENDS 231 Section 001 Van Duzer, Leslie <b>Occupancy:</b> 149			
13:00	13:30	PSYC 100 Section 002 Rawn, Catherine <b>Occupancy:</b> 371		PSYC 100 Section 002 Rawn, Catherine <b>Occupancy:</b> 371		PSYC 100 Section 002 Rawn, Catherine <b>Occupancy:</b> 371
13:30	14:00					
14:00	14:30	PSYC 102 Section 005 Paulhus, Delroy <b>Occupancy:</b> 135	PSYC 102 Section 006 Klonsky, David <b>Occupancy:</b> 316	PSYC 102 Section 005 Paulhus, Delroy <b>Occupancy:</b> 135	PSYC 102 Section 006 Klonsky, David <b>Occupancy:</b> 316	PSYC 102 Section 005 Paulhus, Delroy <b>Occupancy:</b> 135
14:30	15:00					
15:00	15:30					CIVIL 21 Section T2A Laval, Bernard <b>Occupancy:</b> 103
15:30	16:00					
16:00	16:30					
16:30	17:00					

Table 04: CIRS Auditorium Class Schedule and Expected Occupancy

Auditorium Maximum Fresh Air Supply Requirements and Needs							
Activity Type	Surface Area	Maximum Occupancy	Maximum Outdoor Air Requirement				
	[m <sup>2</sup> ]	[people]	[people/100 m <sup>2</sup> ]	[L/s-person]	L/s- m <sup>2</sup>	For the CIRS Auditorium at Max Occupancy [L/s]- People Criterion	For the CIRS Auditorium Independently of Occupancy [L/s] – Area Criterion
Auditorium	465	426	92	8	12	3408	5580

Table 05: Auditorium Maximum Fresh Air Supply Requirements and Needs

Auditorium Average Fresh Air Supply Requirements and Needs							
Activity Type	Surface Area	Average Occupancy	Average Outdoor Air Requirement				
	[m <sup>2</sup> ]	[people]	[people/100 m <sup>2</sup> ]	[L/s-person]	L/s- m <sup>2</sup>	For the CIRS Auditorium at Average Occupancy [L/s]- People Criterion	For the CIRS Auditorium Independently of Occupancy – Area Criterion
Auditorium	465	192	41	8	12	1536	5580

Table 06: Auditorium Average Fresh Air Supply Requirements and Needs

## Available Sensors

The sensors in the auditorium serve a clear purpose: help in the assessment of the thermal comfort and air quality provided by the system. Three parameters (CO2 concentration, relative humidity and temperature) are monitored. As can be seen several sensors distributed all over the auditorium are used to measure one environmental variable (Four for temperature, 3 for CO2 concentration, 3 for relative humidity). This is way more than commonly encountered in most buildings. The majority of the buildings will have at most one thermostat per zone to control the heating or cooling ventilation. From a comparative and purely subjective perspective the selection of sensors to monitor the environment offered by the auditorium is more than adequate. However scientifically, how relevant is the information provided by the sensor and what are the limitation of this selection is another story. Comments will be made with regards to this limitation is the relevant section of this report. But for the sake of argument and to support the idea currently stated a quick overview will be given as to the implications of those limitations. According to Ashrae standard 55 there are six important parameters that are involved in the assessment and definition of the thermal comfort (metabolic rate, clothing insulation, air temperature, radiant temperature, air speed and humidity) three of which, as can be readily noticed, are not measure by those sensors .

This constitute a limitation on top of the fact that the relevancy of the info is dependent on how well the air mixes and how fast is the uniformity achieved. Discomfort can be provoked by other factors too, such as the vertical temperature gradient that cannot be measured through these sensors. Other limitations can be found when it comes to assessing thermal comfort or air quality using those sensors.

List of The Auditorium Sensors			
Sensor	Brand	Model Reference	Additional Information
Temperature Sensor #1	Honeywell	TR21	Appendix 10
Temperature Sensor #2	Honeywell	TR21	Appendix 10
Temperature Sensor #3	Honeywell	TR21	Appendix 10
Temperature Sensor #4	Honeywell	TR21	Appendix 10
CO2 Sensor #1	Honeywell	C76C32A	Appendix 11
CO2 Sensor #2	Honeywell	C76C32A	Appendix 11
CO2 Sensor #3	Honeywell	C76C32A	Appendix 11
CO2 Sensor #4	Honeywell	C76C32A	Appendix 11
Relative Humidity #1	Honeywell	H7635A1006	Appendix 5
Relative Humidity #2	Honeywell	H7635A1006	Appendix 5
Relative Humidity #3	Honeywell	H7635A1006	Appendix 5

Table 07: List of Auditorium Sensors Used to Extract Data For This Study

List of The Auditorium Sensors			
Sensor	Sensor	Sensor	Sensor
Window Opening #1	Window Opening #2	Window Opening #3	Window Opening #4

Table 08: List of Auditorium Sensors Not Used to Extract Data For This Study

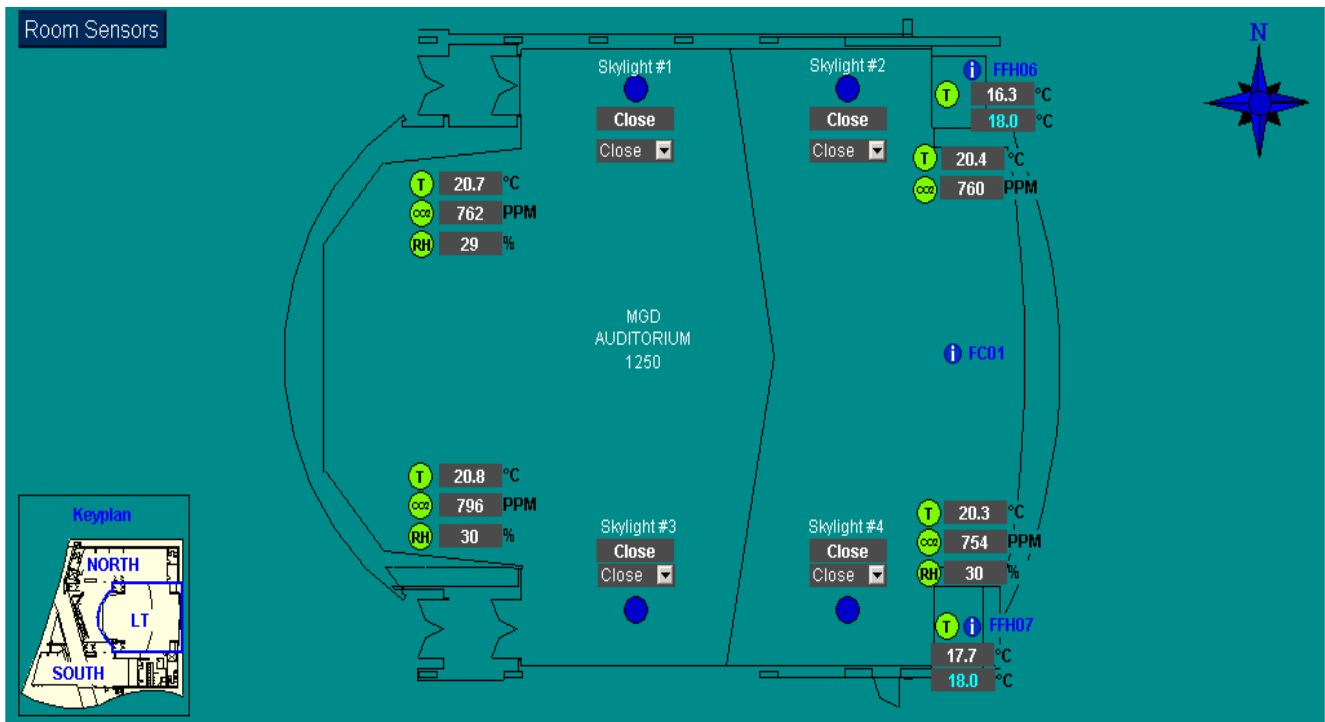

Figure 02: Auditorium BMS Screen-shot - Sensors Layout

### c) The Control Strategy

The control strategy was revised in the *sequence of operation for the HVAC controls manual provided by STANTEC*. The temperature of the supply air is regulated according to the temperature set point in the auditorium. This regulation occurs through several mechanisms. The activation of the heating coil pump, the regulation of how much outlet air is drawn and therefore how much air is recirculated. This regulation is controlled by damper positioning. The heating coil valve position is controlled. The amount of output air drawn is restricted by the CO2 and VOCs concentrations levels in the room. The volume of the supply air being delivered by the AHU is adjusted to maintain a duct static pressure in the duct-work required to maintain control on a normal operating cooling load design day.

During the project the control strategy was revised and modified. The revision occurred in between the two testing periods, around the end of February. The revision was motivated by an excess noise coming from the suction of the air into the return duct work. Some outlet vents have been plugged. The new *Control Strategy/Sequence of Operations* can be found in the Appendix 12; some of the main control strategies are presented:

- Warming Period: 2 hours prior to class start schedule
- The mixing dampers will modulate to maintain the supply air temperature at its set point.

- When heating is required:

Mixing Dampers=> Min OA

HC and HCP ON If Fan ON and OA <13 degrees.

The heating valve will be modulated to maintain the supply air temperature at set point.

The heating coil pump will remain on until the outside air temperature rises to 15°C

The supply fan speed will be modulated to maintain the supply air flow at its scheduled set point value.

OA Flow = % SA Flow

If (RA [CO2]) – (Ambient [CO2])>750 ppm = OA Damper Max Open Position

The SA Flow: Between 3000 l/s and 6000 l/s (Adjustable) [CO2] and [VOCs] dependent.

*This element of the control strategy can be observed on March 21 (Appendices 62 and 63)*

Data was extracted from the different relevant sensors for 5 days on automatic mode. If the trends of March 19 (Monday, Automatic Mode) are compared to those of March 5 (Monday, Override Mode, experiment 1 of trial 2) lots of similitude are noticed which supports the claim that experiment 1 is pretty representative of a normal day of operation (Compare Appendix 42 to Appendix 58). However the average system's power consumption on that day is 37 Kw while on March 5 it was 48.64 Kw (Appendices 56 and 68). March 5 was in average 1 degree Celsius colder which partially explains the difference and the real time adaptation of some of the parameters enable additional savings with respect to the reference experiment day.

On March 19 the average SA Flow is 3000 L/s and the OA Damper averages 52% opening while on March 5 it is set to be 4000 L/s for a OA Damper position fixed at 50% opening.



### III- Data and Methodology

Evaluating the ventilation system's performance usually requires measurement of the parameters describing its state and functioning. A considerable opportunity here, as has been seen in the previous section of this report, is the availability of numerous sensors sending data to a centralized system. The measurements obtained are compared to the design values and the standards for such building and space usage.

The system's behavior and some of the parameters making up the living space of the auditorium are monitored over two seven days periods during which the system's controls are overridden and one 5 days period during which they are left on automatic; all this in different operating and environmental conditions. The change in environmental conditions is imposed by the daily weather and tracked through the monitoring of the outside temperature and relative humidity. The narrowness of the testing period makes it as such that no significant changes are expected. The operating conditions are changed by overriding the automatic control of the ventilation system. The changes follow a certain protocol that dictates the monitoring of a reference day of operation where certain parameters are manually fixed and than the monitoring of others days of operations; each of which is characterized by a change in one of these fixed parameters. As will be seen in the "*Experimentation Planning*" section of this report, the protocol is devised prior to the period of interest and is distributed to the relevant CIRS staff and project mentors. To assess the air change rate when the auditorium presents a high occupation density the Equilibrium Carbon Dioxide Analysis is used, the method is described in the "*Ventilation Rate and Air Change*". The feasibility and limitations of using such a technique for an auditorium is described. To consolidate the results, the analysis is repeated several times over the two 7 days period. To further consolidate the results a Tracer Gas Decay Method is relied upon. In terms of energy consumption 3 factors are considered and explanations given in the relevant section: the fans motor energy consumption deduced by the monitoring of the amperage, the energy inputted through the heating coil deduced by thermodynamically analyzing the air before and after the coil and finally the energy recovered in the heat recovery unit common to air handler 1 and 2. The air quality is assessed by comparing the concentration level of CO<sub>2</sub> and VOCs in the auditorium with accepted values. The limitations of such assessment is deduced from literature review and an proper understanding of the sensors positioning and specifications.

#### a) *Experimentation Planning*

A set of experiments is devised in such a way to provide a better understanding of the effect the different parameters of the ventilation system have on the living environment provided by the auditorium and the effect on the energy consumption of the system. One experiment is conducted per day and the living environments parameters as well as the ventilation system parameters are monitored from 9am to 4pm during the testing period. There are 4 controllable parameters of the ventilation system that can affect the living space: the ventilation rates, the room temperature set point, the windows opening, the ratio of fresh air to recirculating air.

The series of experimentation is to be conducted over two periods of the year one in February one in March with the intention to test the behavior of the system in significantly different ambient/atmospheric conditions dictated by seasonal changes (assuming that a month separating the two periods is enough to observe an significant change in ambient conditions). Precisely the experiments are set for February 6 for the first set of experiments and March 5 for the second.

The system is also monitored in it's normal state during a period succeeding the second experimentation trial period for 5 days (March 19 to March 23).

Experimentation Protocol Table 1				
	Experiment 1	Experiment 2	Experiment 3	Experiment 4
<b>Experience Title</b>	Reference	Windows Opened	Minimal Flow Rate	Medium Flow Rate
<b>Description</b>	The ventilation system is left on automatic mode – No intervention. The energy consumed and recovered is evaluated. The thermal comfort and air quality are assessed based on normal operating conditions.	The ventilation System is left on automatic mode – Two of the 4 windows are left opened. The other parameters are fixed to the reference values assigned in experiment 1. The energy consumed and recovered is evaluated. The thermal comfort and air quality are assessed based on modified operating conditions.	The ventilation automatic control is over-ridden. The VFDs frequency of the fan motors are set to obtain 33% of the max flow rate capacity. The other parameters are fixed to the reference values assigned in experiment 1. The energy consumed and recovered is evaluated. The thermal comfort and air quality are assessed based on modified operating conditions.	The ventilation automatic control is over-ridden. The VFDs frequency of the fan motors are set to obtain 66% of the max flow rate capacity. The other parameters are fixed to the reference values assigned in experiment 1. The energy consumed and recovered is evaluated. The thermal comfort and air quality are assessed based on modified operating conditions
<b>Controlled or Fixed Parameter and Value Assigned</b>	Fixed Windows: Closed Fixed Auditorium Temperature Set point Fixed Supp and Return Fans RPM Fixed Dampers Positions	<b>Controlled Windows: 2X Opened</b> Fixed Auditorium Temperature Set point Fixed Supp and Return Fans RPM Fixed Dampers Positions	Fixed Windows: Closed Fixed Auditorium Temperature Set point <b>Controlled Supp and Return Fans RPM</b> Fixed Dampers Positions	Fixed Windows: Closed Fixed Auditorium Temperature Set point <b>Controlled Supp and Return Fans RPM</b> Fixed Dampers Positions

Table 09: Experimentation Protocol

Experimentation Protocol Table 2			
	Experiment 5	Experiment 6	Experiment 7
<b>Experience Title</b>	Decreased Temperature Set Point	Fresh Air Intake Control	Fresh Air Intake Control
<b>Description</b>	The Auditorium temperature set point is decreased with respect to reference by 2 degrees. The other parameters are fixed to the reference values assigned in experiment 1. The energy consumed and recovered is evaluated. The thermal comfort and air quality are assessed based on modified operating conditions.	The outside, return and exhaust damper positions are changed with respect to reference in order to decrease the amount of fresh air intake. The other parameters are fixed to the reference values assigned in experiment 1. The energy consumed and recovered is evaluated. The thermal comfort and air quality are assessed based on modified operating conditions.	The outside, return and exhaust damper positions are changed with respect to reference in order to decrease the amount of fresh air intake. The other parameters are fixed to the reference values assigned in experiment 1. The energy consumed and recovered is evaluated. The thermal comfort and air quality are assessed based on modified operating conditions.
<b>Controlled or Fixed Parameter and Value Assigned</b>	Fixed Windows: Closed  <b>Controlled Auditorium Temperature Set Point</b>  Fixed Supp and Return Fans RPM  Fixed Dampers Positions	Fixed Windows: 2X Closed  Fixed Auditorium Temperature Set Point  Fixed Supp and Return Fans RPM  <b>Controlled Dampers Positions</b>	Fixed Windows: Closed  Fixed Auditorium Temperature Set Point  Controlled Supp and Return Fans RPM  <b>Controlled Dampers Positions (S, M, R)</b>

Table 10: Experimentation Protocol Continued

## b) Ventilation Rates and Air Change

### Ventilation

As seen in the *Systems Description and Control Strategy* part of the report there are 3 sensors of interest that measure: the outside air flow rate, the exhaust air flow rate and the supplied air flow rate. The supplied ventilation rate can in theory be readily obtained and the ratios of flow rate per occupant or flow rate per square meter can be compared with the standards requirements for similar buildings. During the first experimentation period, the results for these flow rates were deemed inconsistent and appeared to be caused by erroneously calibrated sensors. The sensors were sent back to a relevant 3<sup>rd</sup> party for recalibration. The knowledge of the flows are crucial to this study so a backup plan is elaborated and followed. The VFDs installed on the fan motors are set as they were during the experiments.

With a hot-wire anemometer the flow rates are measured using a standardized protocol. Adjustments are made based on the density of air which is dependent on the relative humidity and temperature at the time of the measurement.

The adjustments are made according to the following line of thoughts: Considering a derivative of the fans affinity laws:

$$(Q_1/Q_2) = (D_1/D_2)^2 (P_1/P_2)^{1/2} (\rho_1/\rho_2)^{-1/2}$$

Q = Mass Flow Rate

D = Impeller Diameter

P = Supply Pressure

$\rho$  = Density

Where the sub-index 1 represents the conditions at the time of the experiment and the sub-index 2 the simulated conditions. We set  $P_1 = P_2$  by controlling the supply pressure set point.

$$Q_1 = (\rho_1/\rho_2)^{-1/2} * Q_2$$

Where the densities are obtained based on the relative humidity and temperature of air measured by the available sensors and the flow  $Q_2$  by manual measurement.

If the supplied air temperature is below 40 degrees, the change in densities can be neglected.

## Air Change Assessment Using The CO2 Concentration Equilibrium Point Methodology

The equilibrium technique for the assessment of the air change rate can be used when the outside CO2 concentration and the CO2 generation within the system analyzed is constant. In this case an equilibrium concentration will be reached at a certain point in time within the system. During a class, even if the CO2 generation rate is constant, due to the maintained occupancy level of the auditorium, equilibrium might not be reached due to insufficient time. The only way to determine this is to observe the data extracted from the CO2 sensors and determine if at some point in time during a class the CO2 concentration level stabilizes itself. If the outdoor CO2 concentration  $C_{out}$  is constant and the average CO2 generation rate per person out  $G_p$  is known, then the outdoor airflow rate  $Q$  into the building is given by the following equation:

$$Q = \frac{\text{Number of occupants} * G_p}{C_{eq} - C_{out}}$$

The value of  $G_p$  depends on a person's age and activity level. A typical value of  $G_p$  for office buildings is  $5.3 \times 10^{-6} \text{ m}^3 / \text{s}$  (0.011 cfm) per person. The value of  $Q$  is divided by the building volume  $V$  to determine the air change rate.

## Air Change Assessment Using a Tracer Gas Methodology

The technique consist in turning off the ventilation system and than releasing a certain amount of pressurized *tracer-gas* from a cylinder. This amount is determined in a way that, when released in the auditorium, it results in a detectable change of the *tracer-gas* concentration that lasts despite the system's leaks prior to the start of the experiment. The gas is allowed to mix with the internal air while the fan in the air-handling unit is switched off. The fan is then switched on and the decay of the concentration of the tracer gas is monitored over a given time interval:

$$C_{(t)} = C_{(0)}e^{-\lambda t}$$

The logarithm of the tracer-gas concentration is plotted against the elapsed time and the slope of the line is equal to  $\lambda$ . This technique can be accurate when it is used in buildings and rooms because the change rate is low and by using a portable fan a good mixing of the gas and the air can be achieved.

The Volume of the auditorium in liters is determined by looking at the relevant drawings.

There are no limitations as of the choice of the tracer-gas that can be chosen as long as it can be detected by the tools in the experimenter's possession and as long as it is in conformity with the safety standards set for this technique which are pretty obvious and will not be stated (orderless gas, non flammable, non toxic etc...)

There are usually two possible protocols/methodologies that can be followed when proceeding with this technique:

The first one consist in turning the system into a living laboratory equipped with sensors by having the analysis equipment on site (which is, in some way, what the auditorium is with all the sensors it presents; provided an adequate choice of tracer gas). This first method can be very cumbersome and costly.

The other way would be to extract (by pumping into sealed sample bags) an air mixture sample at different point in time and send it to an external lab for analysis of the changing of the tracer-gas concentration within the mixture.

The test is usually performed in a closed system, emptied from all occupants. It was chosen that the experiment should take advantage of the existing ability to accurately measure CO<sub>2</sub> on site; as a result CO<sub>2</sub> was chosen as a tracer gas. One would need to significantly increase the auditorium's CO<sub>2</sub> level above the ambient concentration for the measurements to be relevant and for the measurements not to beaffected by the "noise" created by the environment. It was planned that CO<sub>2</sub> cylinders would be bought and the gas released in the auditorium at the time of the testing to significantly increase the CO<sub>2</sub> concentration levels.

The initial concentration of CO<sub>2</sub> in the auditorium environment is equal to :

$$C_i = \frac{m_i}{V_{auditorium}} \text{ Which is around 400ppm}$$

A pressurized CO<sub>2</sub> cylinder of Volume  $V_{cylinder}$  in liters containing a mass  $m_{cylinder}$  milligrams of CO<sub>2</sub> is obtained.

The new CO<sub>2</sub> concentration level to be expected and detected after the release is:

$$C_n = \frac{m_i + m_{cylinder}}{V_{auditorium}} \text{ PF}$$

An arbitrary value is chosen such as  $C_n > 2 \times C_i$  the amount of cylinders or size of the cylinder needed can be readily derived from these results.

As it will be shown in the results section of this report associated with this topic the plan was modified.

### c) Energy Consumption

In this part of the study, the energy consumption of the fans, the energy input into the supplied air and the energy recovered are of interest. The methodology followed to obtain each of these parameters is described.

#### The Fans

The power drawn by the motor of each fan is either directly measured (trial 2) or can be calculated (trial 1) since the current is independently measured:

$$P = \sqrt{3} * V * I * PF$$

Where the value of the current  $I$  is obtained from the sensors available on site and logged in the system. The voltage is readily obtained and the power factor assumed.

#### Heating of the Air

When needed heat is added to the air mixture (outlet air and return air) prior to being supplied to the auditorium. The energy added by the coils is nothing but the difference in enthalpy of the air mixture and the supply air. The enthalpy of air is dependent on both the relative humidity and the temperature of the air which are both measured in the system. Many literature elaborate the derivation of the following formulas, for simplicity the engineering toolbox site was consulted and some part are directly quoted from the site.

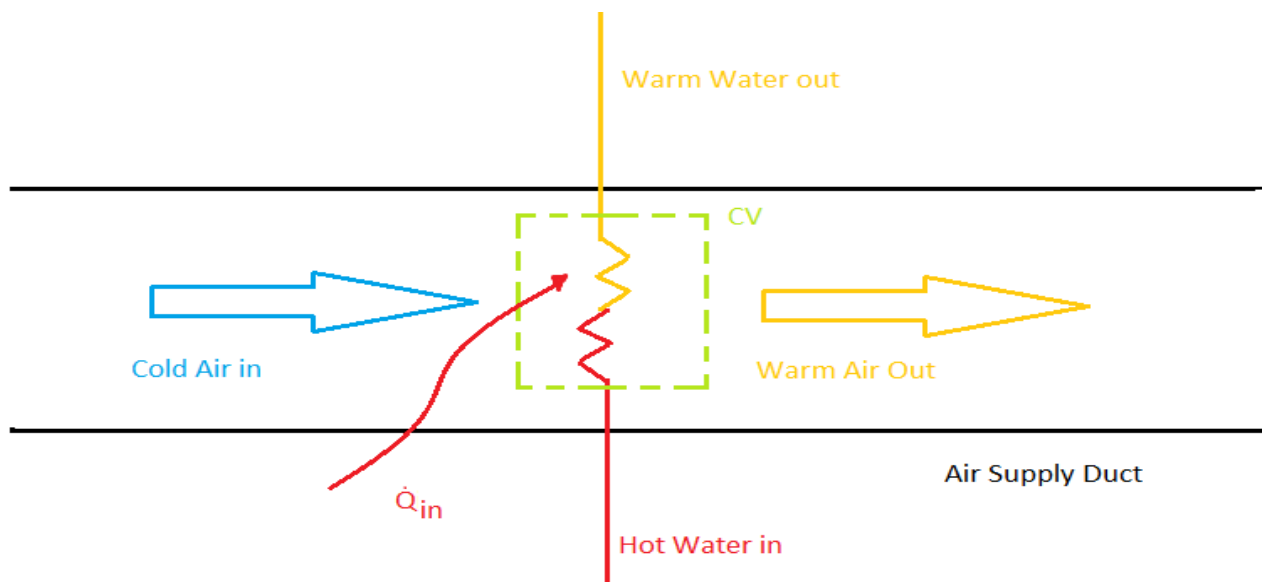

Figure 03: Thermodynamic CV 1<sup>st</sup> Law Analysis on Supply Air

The 1<sup>st</sup> Law of Thermodynamic is applied on a control volume within the air supply duct that encompasses the air passing through the coil only. This is what figure 03 attempts to illustrate.

The simplified equation, assuming steady state and neglecting, kinetic and potential energy is:

$$\dot{Q}_i = \dot{m}(h_o - h_i) \quad \text{Where} \quad \dot{m} = \rho Q$$

- The supply flow Q is measured by a sensor.
- The density requires the knowledge of the relative humidity of the moist air at any point in time, parameter which is measured by a sensor.
- As for the enthalpy, two parameters are to be known, the relative humidity and the temperature of the moist air; these parameters are measured by sensors.

Two equations, taken from the engineering toolbox site are used the density of the air stream can be deduced as well as its enthalpy prior and after the potential heating:

$$[1] \quad h = (1.006 \text{ kJ/kg}^\circ\text{C}) t + x [(1.84 \text{ kJ/kg}^\circ\text{C}) t + (2501 \text{ kJ/kg})]$$

$$[2] \quad \rho = \rho_{da} (1 + x) / (1 + 1.609 x)$$

A sample calculation will be shown in the results section.

## Heat Recovery

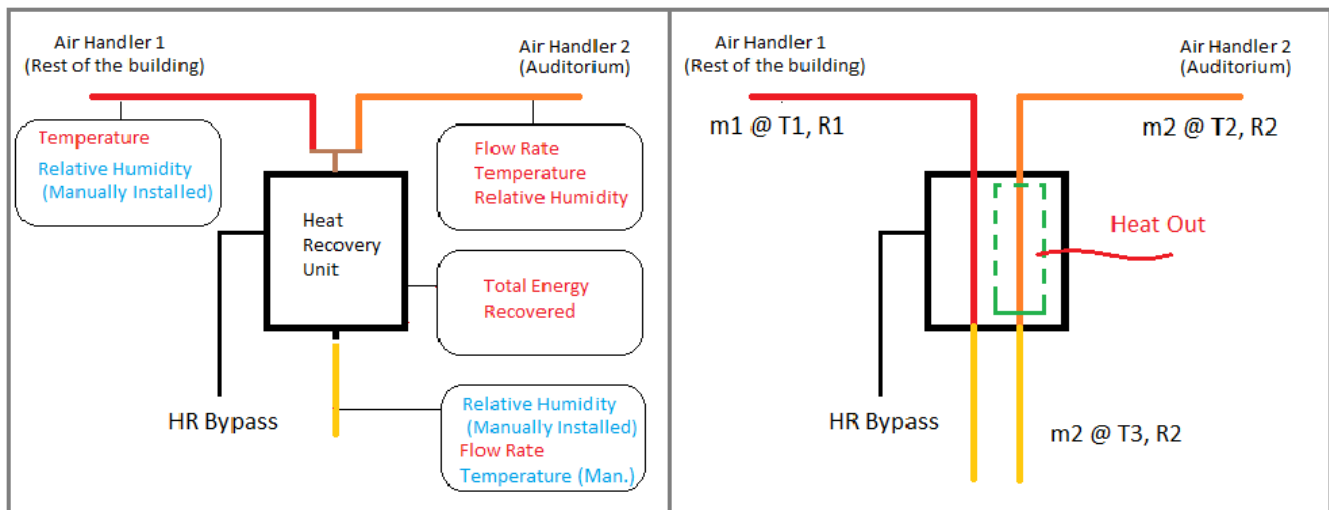

Figure 04: Thermodynamic Model of The Heat Recovery Unit

Note: In this figure m=mass flow rate, T=Temperature, R=Relative Humidity



The outlet ducts of both AHU1 and AHU2 channel the air exhausted from the auditorium and the rest of the building through a heat recovery unit prior to releasing it to the atmosphere. The total energy recovered is provided by a sensor installed at the level of the heat recovery system. However the energy recovered from the outlet air of the auditorium is of greater interest in the context of this study.

Most of the concepts elaborated in the previous section still apply here. To answer the question of how much energy is extracted from the AHU2 however an adequate modeling and choice of the control volume is needed when applying the 1<sup>st</sup> law of thermodynamic. It is imagined that the flows never mix before entering the heat recovery unit. The stream of air from AHU2 is also assumed to leave at the same temperature as that of the mixed outlet air in the actual system

$$\dot{Q}_r = \dot{m}(h_3 - h_2)$$

#### d) Air Quality Assessment

##### Volatile Organic Compounds Concentration [VOCs]:

With regards to air quality, the VOCs concentration is monitored in the auditorium, the results interpreted and compared to accepted standards for such metric and conditions. The limitations of relying on the existing VOC sensors is identified and attention is drawn to what should be further taken into account when it comes to air quality.

VOCs are organic compounds characterized by their tendency to evaporate easily at room temperature. They are quite detectable, but usually only by means of broad-range sensors. Broad-range sensors provide *an overall reading for a general class or group of chemically related contaminants. They cannot distinguish between the different contaminants they are able to detect. They provide a single aggregate reading [TVOC] for all of the detectable substances present at any moment.* The limitation of this is that different VOCs have different permissible exposure limits and a lack of an unacceptable aggregate reading is not necessarily proof of the absence of hazard.

In order to understand the implications of the VOCs concentration measurements, their significance and their limitations in assessing air quality, information is mainly extracted from the related sensor user's manual and presented in this section; other sources are consulted to support the results interpretation.

The Air Quality Monitor being dealt with is a broad-range sensor, it uses a tin dioxide semiconductor based on the Taguchi principle to detect oxidizable gases and is specifically designed to have high sensitivity to gaseous organic materials which are components of indoor air pollutants. The sensor is essentially a heated element inside a porous semi-conductive tube. The tube has a large surface area and is able to freely absorb gas molecules such that electron transfer occurs between the gas and oxygen molecules. This causes a relatively large increase in conductivity for a small change in gas concentration. The change occurs within a few seconds and is completely reversible.

The sensor responds with a varying degrees of sensitivity to a wide variety of gases which include hydrogen, hydrocarbons, alcohols, carbon monoxide, benzene, etc... Some of the detectable pollutants are presented in decreasing order of detection sensitivity in the following table.

Hydrocarbons and body odors which constitute a significant chunk of the VOCs present in a human environment are emitted by breathing and perspiration. The level of these contaminants change at roughly the same rate as CO<sub>2</sub> and the sensor will track these contaminants at the same rate as the CO<sub>2</sub> in occupied spaces. Er words it is expected that over a given test period the trends of VOCs and CO<sub>2</sub> concentrations behave the same (to some extend CO<sub>2</sub> concentration could be predicted from the VOCs concentration). Figure 05b illustrate what can be expected in terms of CO<sub>2</sub> and VOCs concentrations in an occupied space such as the auditorium and the correlation between them.

<b>Chemical</b>	<b>Symbol</b>	<b>Common Source</b>
Methyl Ethyl Ketone	C <sub>4</sub> H <sub>8</sub> O	Solvents and cleaning products
Acetone	C <sub>3</sub> H <sub>6</sub> O	Solvents and organic synthesis
Ethyl Alcohol	C <sub>2</sub> H <sub>6</sub> O	Solvents and liquor fermentation
Formaldehyde	CH <sub>2</sub> O	Disinfectants and preservatives
Hydrogen	H <sub>2</sub>	Used in synthetics
Methyl Alcohol	CH <sub>4</sub> O	Solvents, antifreeze and synthetics
Vinyl Chloride	C <sub>2</sub> HCl	Textiles and polymers
Hydrogen Sulfide	H <sub>2</sub> S	Water and putrefying matter
Methyl Chloride	CH <sub>3</sub> Cl	Solvents, paints and refrigerant
Benzene, Toluene, Xylene	C <sub>6</sub> H <sub>6</sub> , C <sub>7</sub> H <sub>8</sub> , C <sub>8</sub> H <sub>10</sub>	Solvents and motor fuels
Trichloroethylene	C <sub>2</sub> HCl <sub>3</sub>	Solvents and cleaning agents
Propane	C <sub>3</sub> H <sub>8</sub>	Fuels and chemical synthesis
Carbon Monoxide	CO	Combustion of carbon
Freon-22	CHClF <sub>2</sub>	Refrigerants and aerosols
Ammonia	NH <sub>3</sub>	Solvents and refrigerants
Methane	CH <sub>4</sub>	Decomposition and synthesis

Figure 05a: Detectable VOCs

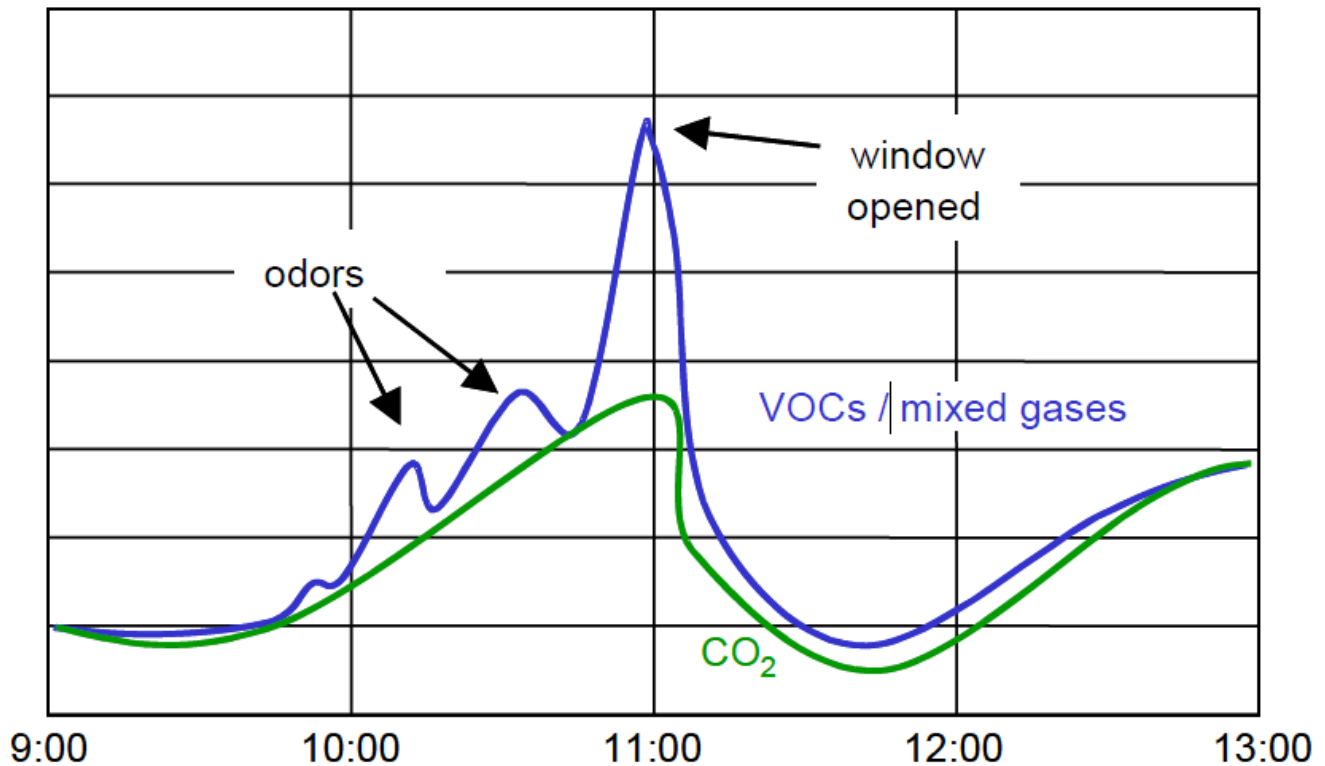

Figure 05b: Correlation of CO<sub>2</sub> and VOCs Concentrations as Measured in a Typical conference Room

### Carbon Dioxide Concentration [CO<sub>2</sub>]:

The carbon dioxide, at levels such as usually encountered in living spaces, does not represent a health hazard but can be a major source of discomfort and dizziness for occupants if present in a considerable level within an occupied space, such as the auditorium being studied.

The acceptable range for both VOCs and CO<sub>2</sub> concentrations vary according to the type of activity occurring within the living space. Most (older) ventilation systems are not equipped with VOCs and CO<sub>2</sub> sensors and guarantee that the living environment has an adequate range of VOCs and CO<sub>2</sub> concentration through sufficient air renewal rates (i.e. fresh air intake) which are set by the standards, based on room occupation and activity type (this has been covered in previous sections of this report).

The advantage of having those sensors available is that energy savings can be obtained through some modifications (such as a fan speed decrease) at the expense of air quality until critical levels are reached and the energy saving changes can be attenuated/reverted in order for the monitored parameters to remain in tolerable ranges.

The procedure is quite straight forward, verify that at all time, whatever the control changes implemented, the CO<sub>2</sub> concentration in the auditorium stays within the limits: under 1000ppm.

### e) Thermal Comfort Assessment

ASHRAE has developed a standard (known as ASHRAE Standard 55-2004 Thermal Environmental Conditions for Human Occupancy ) to describe comfort requirements in buildings. This standard specifies the combinations of indoor thermal environmental factors and personal factors that will produce thermodynamic environmental conditions acceptable to most occupants within the space.

A comfort psychrometric chart is derived from this set of guidelines and can applied to spaces where the occupants have activity levels associated to metabolic rates between 1.0 met and 1.3 met and where clothing is worn that provides between 0.5 clo and 1.0 clo of thermal insulation. The comfort zone is based on the PMV values between -0.5 and +0.5.

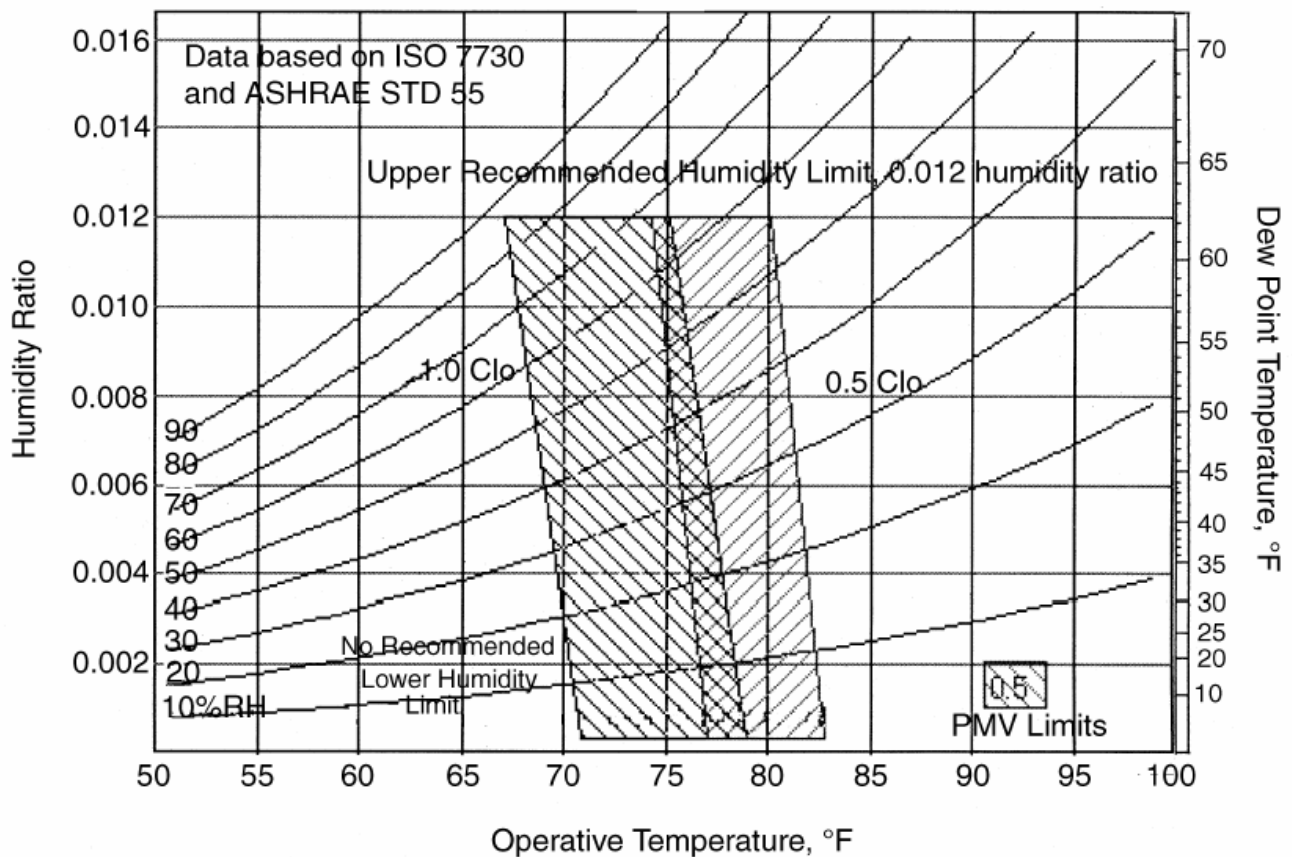

Figure 06: ASHRAE Standard 55-2004 Comfort Psychrometric Chart

A survey was to be conducted at the end of each class given in the auditorium where each student would have chosen a score among a predefined set of scores to evaluate his perception of the thermal comfort. However due to some difficulties encountered and advice provided by the supervisor the survey aspect of the study was dropped.

For each class the average temperature as well as the average relative humidity is placed on the graph to assess whether thermal comfort is achieved according to this definition and for the given experiments, the results are posted in a table.

## IV- Data Interpretation and Analysis – Results

**Note: Appendices 26 to 68 are crucial to the understanding of this part of the report!**

### *a) Experimentation Outcome: Actual Occurrence and Obstacles Encountered*

The experiments were intended to be performed as planned but a series of obstacles, encountered during the 1<sup>st</sup> testing period, delayed their execution and others affected the rigorousness of the methodology or lead to a partially inconsistent/unreliable data collection. This defeated the intention of having two comparable sets of experiments, however it presented the opportunity to be used as a learning element to refine the methodology and avoid mistakes in the next trial. Obtaining inconsistent results usually motivates a repetition of the trial (as in replacing the 1<sup>st</sup> set of experiments) but this was not done for several reasons:

- 1<sup>st</sup> of all the experimentation process requires a considerable involvement and attention from behalf of the building operator who cannot be asked full dedication to this project.
- 2<sup>nd</sup> of all the inconsistent results are valuable in a sense that they pinpoint weaknesses in the system and potential defects and are also representative of the kind of obstacles that can be encountered in any potential future analysis of the system.
- Finally keeping the situation as such is very consistent with engineering work where projects executions seldom occur without obstacles.

During the month of February, the system was still being commissioned, tested and altered by third parties; its whole control strategy was revised, making the comparison between the two sets of experimentation unfeasible.

As can be noticed from the following table no obstacle were encountered during the second round of experiments. In this trial, resembling experiments were placed during days of similar class schedule to reduce the occupancy effect and focus on the changes implemented outcome.

It was noticed in the 1<sup>st</sup> run that heat recovery was sometimes bypassed by automatic control so this was avoided by overriding the damper positions for exhaust air streams to be channeled through the heat recovery units.

No incidents were recorded during the 5 days of automatic operation monitoring however odd results were noted on March 22 and 23 (Appendices 64 to 67) such as an unusually low energy consumption on March 23 as if there was no heating at all of the air and an unjustified interruption of the heating from 11am to 1pm on March 22 (despite the fact that the OA was 5 degrees).

**Experiments Schedule and Protocol Followed**

Experiments and Schedule	Wednesday Feb 8	Thursday Feb 9	Friday Feb 10		
	Windows: Closed	Windows: 2 open	Windows: Closed		
	Room Temp: 21C	Room Temp: 21C	Room Temp: 19C		
	Supply fan: 60Hz	Supply fan: 60Hz	Supply fan: 60Hz		
	Return fan: 54Hz	Return fan: 54Hz	Return fan: 54Hz		
	Supply air damper: 50%	Supply air damper: 50%	Supply air damper: 50%		
Obstacles Encountered	System override remotely overridden by contractors. Dampers Position drifted away from 50% from 10:50 to 11:15 and system went back on automatic from 2:20 to 2:30	Faulty window opening indicator	System override overridden by contractors. Return fans were set to 70Hz instead of 54Hz for a brief period of time from 8:19 to 8:24		
Experiments and Schedule	Monday Feb 13	Tuesday Feb 14	Wednesday Feb 15	Thursday Feb 16	
	Windows: Closed	Windows: Closed	Windows: Closed	Windows: Closed	
	Room Temp: 21C	Room Temp: 21C	Room Temp: 21C	Room Temp: 21C	
	Supply fan: 20Hz	Supply fan: 40Hz	Supply fan: 60Hz	Supply fan: 60Hz	
	Return fan: 18Hz	Return fan: 36Hz	Return fan: 54Hz	Return fan: 54Hz	
Supply air damper: 50%	Supply air damper: 50%	Supply air damper: 30%	Supply air damper: 70%		
Obstacles Encountered	Override interrupted because critical level of CO2 were reached in the auditorium	System crash, data collection interrupted	Heating valve forced at 100% opening by contractors from 10am to 3pm	Heating valve forced at 100% opening by contractors from 8:55am to the end of the day	
Experiments and Schedule	Monday March 5	Tuesday March 6	Wednesday March 7	Thursday March 8	Friday March 9
	Windows: Closed	Windows: Closed	Windows: Closed	Windows: Closed	Windows: Closed
	Room Temp: 21C	Room Temp: 21C	Room Temp: 21C	Room Temp: 21C	Room Temp: 21C
	Supply fan: 60Hz	Supply fan: 24Hz	Supply fan: 60Hz	Supply fan: 42Hz	Supply fan: 60Hz
	Return fan: 54Hz	Return fan: 21.6Hz	Return fan: 54Hz	Return fan: 37.8Hz	Return fan: 54Hz
	Supply air damper: 50%	Supply air damper: 50%	Supply air damper: 30%	Supply air damper: 50%	Supply air damper: 70%
	HRC - full coil	HRC - full coil	HRC - full coil	HRC - full coil	HRC - full coil
Match with March 12	Match with March 8, 13	Match with March 9	Match with March 6, 13	Match with March 7	
Experiments and Schedule	Monday March 12	Tuesday March 13	Wednesday March 14	Thursday March 15	Friday March 16
	Windows: Open	Windows: Closed			
	Room Temp: 21C	Room Temp: 19C			
	Supply fan: 60Hz	Supply fan: 60Hz			
	Return fan: 54Hz	Return fan: 54Hz			
	Supply air damper: 20%	Supply air damper: 50%			
HRC - full coil	HRC - full coil				

**Table 11: Experimentation Placement, Protocol and Obstacles Encountered**

## *b) Ventilation Rates Assessment Results*

### **Ventilation**

In the middle of the semester it was noted that two (EA, OA) out of the three flow sensors of the Air Handling Unit of the auditorium were uncalibrated. Unfortunately in this case, the knowledge of the flows are crucial in a ventilation system assessment study. A “plan B” was needed which consisted of manual measurements. This “plan B” presented numerous limitations that are going to be commented. The ventilation flows are a result of several factors such as the fan speeds, the dampers positions, the ambient conditions (relative humidity of air and thus density). If the system is left on automatic the dampers positions will keep on changing and one has no control over ambient conditions which makes it impossible to recreate a situation for every condition where the measured flow would be representative of what was actually happening at a certain point in time of interest. During the experimentation process, the automatic control was overridden; while many parameters differ from one experiment to another they all present a common set of parameters: mainly the fan speeds and damper positions. It was decided that the measurement would be taken at normal operating conditions fan speeds and the two fan speeds that were tested during two experiments along an average damper position of 50%. It was deemed, that if accurate, the results would be representative enough of the overall system's behavior but wouldn't allow elaborate derivations of energy involvement which require accurate measurements. The measurement were performed by a trained technician due to the restricted access of the ventilation system's room to students. As can be noted from the table to follow, two techniques were relied upon which are air velocity and pressure measurements; flows were subsequently derived and compared to the flow-meter readings. Due to the difficulty in accessing the system, the air velocity measurement couldn't follow standardized protocols described in the reviewed sources and thus resulted in inaccurate and unreliable results. The results derived from pressure measurements were deemed more reliable. It is worthy to note that outside air intake flow can be derived from CO<sub>2</sub> concentration monitoring techniques such as will be covered in the next sections of this report. The results obtained will be compared to the outside air requirement criterion previously cover for both average and maximum occupancy. Please refer to the auditorium space occupancy usage section for further details.

Air Flow Measurements Results										
		Using Measured Pressure				Using Measured Velocity				* Flow Station
Location	Time	Pressure		Calc	Calc	Meas.	Flow		Meas.	
		Meas.	Calc				Calc	Calc		
		inch wc	Pa	Velocity (m/sec)	Velocity (m\sec)	Velocity (m\sec)	m3/sec	liter/sec	liter/sec	
Test 1	HRC	10:59	0.00	0.00	0.00	0	0.2	0.204	204	
	AH2 SA	11:08	0.08	19.92	5.70	6181	1.1	1.192	1192	4281
	AH2 OA	11:12	0.03	7.47	3.49	5522	0.5	0.791	791	2665
	AH2 EA	11:14	0.01	2.49	2.02	3024	0.12	0.180	180	3321
Test 2	HRC	13:15	0.02	4.98	2.85	2914	0.3	0.307	307	2368
	AH2 SA	13:20	0.04	9.96	4.03	4371	1.32	1.431	1431	200
	AH2 OA	13:24	0.00	0.00	0.00	0	0.15	0.237	237	3784
	AH2 EA	13:27	0.00	0.00	0.00	0	0.09	0.135	135	
Test 3	HRC	14:29	0.00	0.00	0.00	0	0.13	0.133	133	
	AH2 SA	14:32	0.01	2.49	2.02	2185	0.22	0.238	238	493
	AH2 OA	14:41	0.00	0.00	0.00	0	0	0	0	-61
	AH2 EA	14:43	0.00	0.00	0.00	0	0	0	0	2447
Test conditions				Duct Dimensions		Duct area	Air Density			
				Meas.	Meas.	Calc	1.225 kg/cubic meter			
	SF (Hz)	RF (Hz)	Dampers	Width (")	Height (")	Area (sq inch)				
Test 1	59.5	53.9	50%	44	36	1584				
Test 2	41.7	32.7	50%	60	28	1680				
Test 3	23.8	21.7	50%	57	43	2451				
				93	25	2325				

Table 12: OA, EA, SA Manual Measurements Results

Outside Air Flow Assessment Using Two Different Techniques – Comparative Table					
	OA Flow @ 50% Damper Position and avg. fans speeds	OA Flow @ 50% Damper Position and medium fans speeds (2/3 avg)	OA Flow @ 50% Damper Position and minimum fans speeds (1/3 avg)	Occupancy based Outside Air Requirement Criterion	Area based Outside Air Requirement Criterion
Average Occupancy	5522 or NA	NA or NA	NA or 2296	1536	5580
Maximum Occupancy	5522 or NA	NA or NA	NA or 2296	3408	5580

Table 13: Outside Air Flow Intake Assessment Using Two Different Techniques

Note: In each cell the left result is based on manual measurements and the right one on [CO2] equilibrium. The color coding is green for two criterion met per evaluation, yellow for one and red for none.



The accuracy of the results obtained is questionable but are revealing of the scale of magnitudes being dealt with and a rough estimate of the ventilation adequacy can be made. The occupancy based criterion is the most relevant one and it is highly met, except at minimal flow. However the inadequacy at minimal flow was also confirmed in later testings where it was noticed that it results in unacceptable CO2 levels concentration being reached. In any case the system automatic control can increase the outside air intake to up to 100% (No recirculating air) if critical CO2 levels are reached.

### Air Change Assessment Using The CO2 Concentration Equilibrium Point Methodology

Reviewing some sources dealing with this matter, it is expected that if equilibrium is not truly reached, the technique would lead to unreliable and overestimated results. The problem in the situation being dealt with is that the auditorium occupancy is permanently fluctuating over brief periods of time making any equilibrium hard to be reached.

However attempts were made to apply the technique while considering time laps where equilibrium is arguably reached. Some results seemed satisfactory and in accordance with the presumably uncalibrated sensors others were deemed irrelevant and inaccurate such as highlighted in the table. The common ground between those two inaccurate results is that they are derived through the assessment of very small changes of concentration levels of the auditorium from ambient conditions. It is suggested that for auditoriums, air change rate should range between 8 and 15 ach. It is not feasible that the outside air is higher than the supply air, which is basically the case in all experiments.

The inaccuracy is mainly due to the occupancy that was not evaluated in real time , the expected amount of CO2 generated per person and finally the shortness of the periods where equilibrium is reached.

[CO2] Equilibrium Methodology Results											
Exp.	Test Period	Time at which [CO2] Equilibrium achieved	Number of Occupants when Eq. Reached	Ambient [CO2] – C(out)	Equilibrium [CO2] – C(eq)	Q[L/s] – Outside Air – Calculated	Outside Air – Measured	Supply Air	Auditorium Volume	Air Change Rate – Based On CO2 Eq	Air Change Rate – Based On Measurement
1	1	No Equilibrium									
2	1	10:15 to 11:00	227	420	720	4010	3680	5663	3240	4.46	4.09
3	1	11:00 to 11:30	202	470	786	3388	3418		3240	3.76	3.80
4	1	11:00 to 11:30	202	411	1201	1355	3369	3607	3240	1.51	3.74
5	1	No Equilibrium									
6	1	11:00 to 11:30	202	513	835	3325	3342	5663	3240	3.69	3.71
7	1	10:00 to 10:30	255	441	529	15358	4669	5663	3240	17.06	5.19
1	2	10:30 to 11:30	202	412	578	6449		3976	3240	7.17	0.00
2	2	12:00 to 13:30	227	427	951	2296		975	3240	2.55	0.00
3	2	10:30 to 11:30	202	486	732	4352		4096	3240	4.84	0.00
4	2	No Equilibrium						3691	3240		0.00
5	2	14:00 to 16:00	103	471	486	36393		3802	3240	40.44	0.00
6	2	10:30 to 11:00	257	406	710	4481		3991			
7	2	10:00 to 11:30	255	406	716	4360		2921	3240	4.84	0.00

Table 14: CO2 Concentration Equilibrium Methodology for OA Flow Assessment Results

## Air Change Assessment Using a Tracer Gas Decay Methodology

When time came to proceed with the air change assessment using the tracer gas decay technique, as originally planned, a specialized company (PIXAIR) was consulted for the purchase of the CO<sub>2</sub>. It appeared that to raise the CO<sub>2</sub> concentration level of the auditorium to the required level of 800ppm (about 400ppm above the ambient CO<sub>2</sub> concentration; this is equivalent to 1295 Kg of CO<sub>2</sub> to be release given the size of the auditorium) a significant and costly amount of CO<sub>2</sub> was to be purchased.

It is worthy to note that if another gas had been chosen such as SF<sub>6</sub>, because of the absence of it in ambient air only a small amount of it would be needed thus reducing the cost of the procedure. However other costs would have been incurred mainly related to the purchase of the air sample extraction equipment (manual pumps and sample bags) and the lab analysis.

CO <sub>2</sub> purchase for the Tracer Gas Decay Methodology: Costs					
Mass			Volume	Concentration	Price at [30\$/20lb]
LB	[Kg]	mg	L	PPM or mg/L	\$
22	10	1.00E+07	3.24E+06	3	\$33
33	15	1.50E+07	3.24E+06	5	\$50
44	20	2.00E+07	3.24E+06	6	\$66
55	25	2.50E+07	3.24E+06	8	\$83
110	50	5.00E+07	3.24E+06	15	\$165
165	75	7.50E+07	3.24E+06	23	\$248
220	100	1.00E+08	3.24E+06	31	\$330
275	125	1.25E+08	3.24E+06	39	\$412.00
2849	1295.2	1.30E+09	3.24E+06	400	\$4,274.00

Table 15: CO<sub>2</sub> purchase for the Tracer Gas Decay Methodology Costs

It was finally decided that instead of purchasing CO<sub>2</sub> and releasing it, the experiment should be conducted after a class where the auditorium would have been occupied for a certain period of time. This would provide the needed CO<sub>2</sub> for free. After a quick glance at the auditorium occupation schedule, classroom services was contacted, the auditorium was reserved for Thursday the 22<sup>nd</sup> of March from 12:30pm to 2pm. During this day, fan speeds and fresh air intake were reduced to minimal but acceptable values to allow the accumulation of CO<sub>2</sub> within the auditorium. At the end of the class, the vacant auditorium was locked and all windows closed, the ventilation system was shut down. About half an hour passed, allowing the concentration of CO<sub>2</sub> in the auditorium referred as initial, to stabilize itself. The system was turned on using the same parameters used in the reference experiment. The CO<sub>2</sub> decay was monitored and the air change rate derived from it as will follow.

# [CO2] Decay Experimentation Day

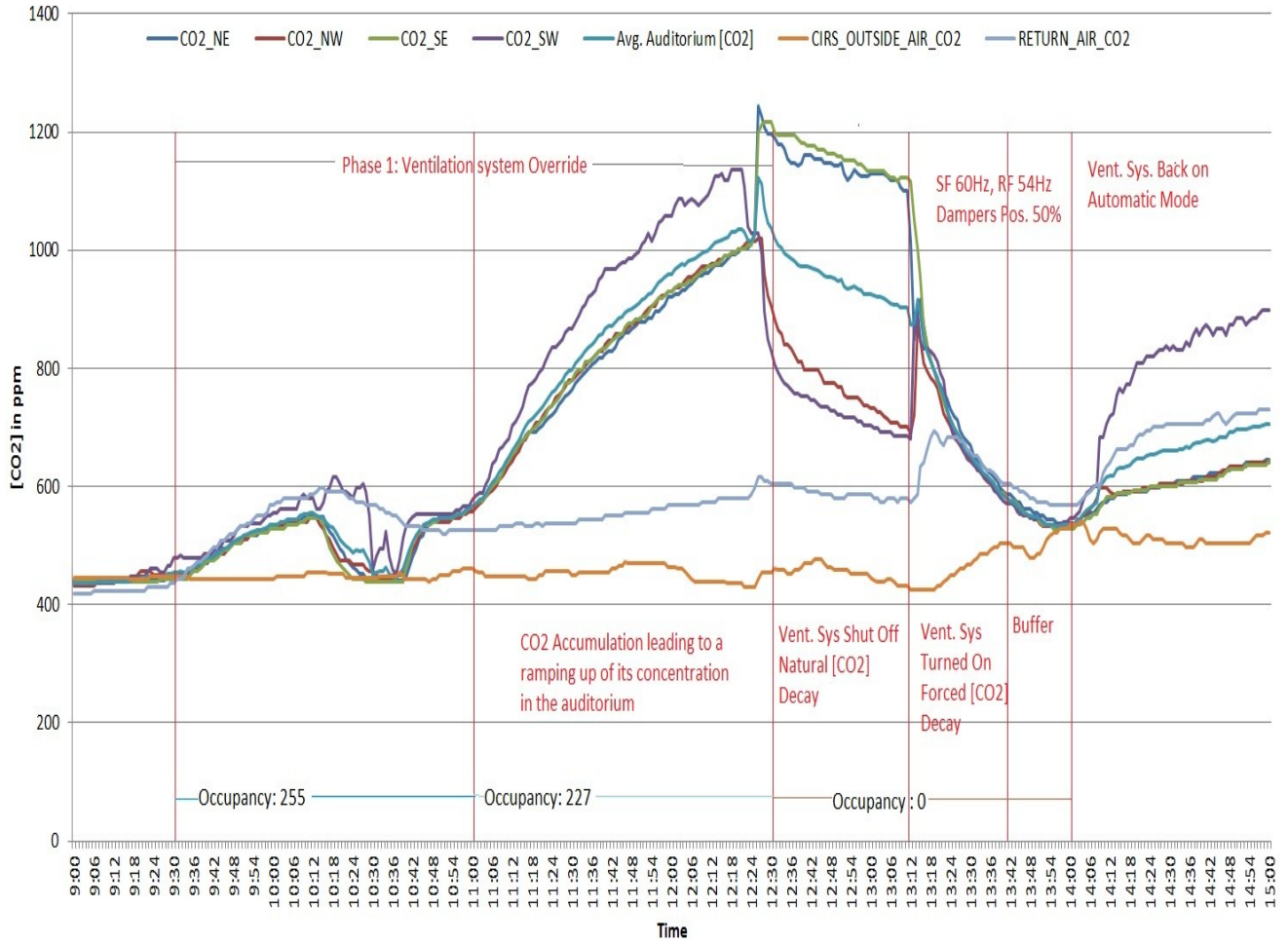

Figure 07: CO2 Concentration Decay Experiment Explained

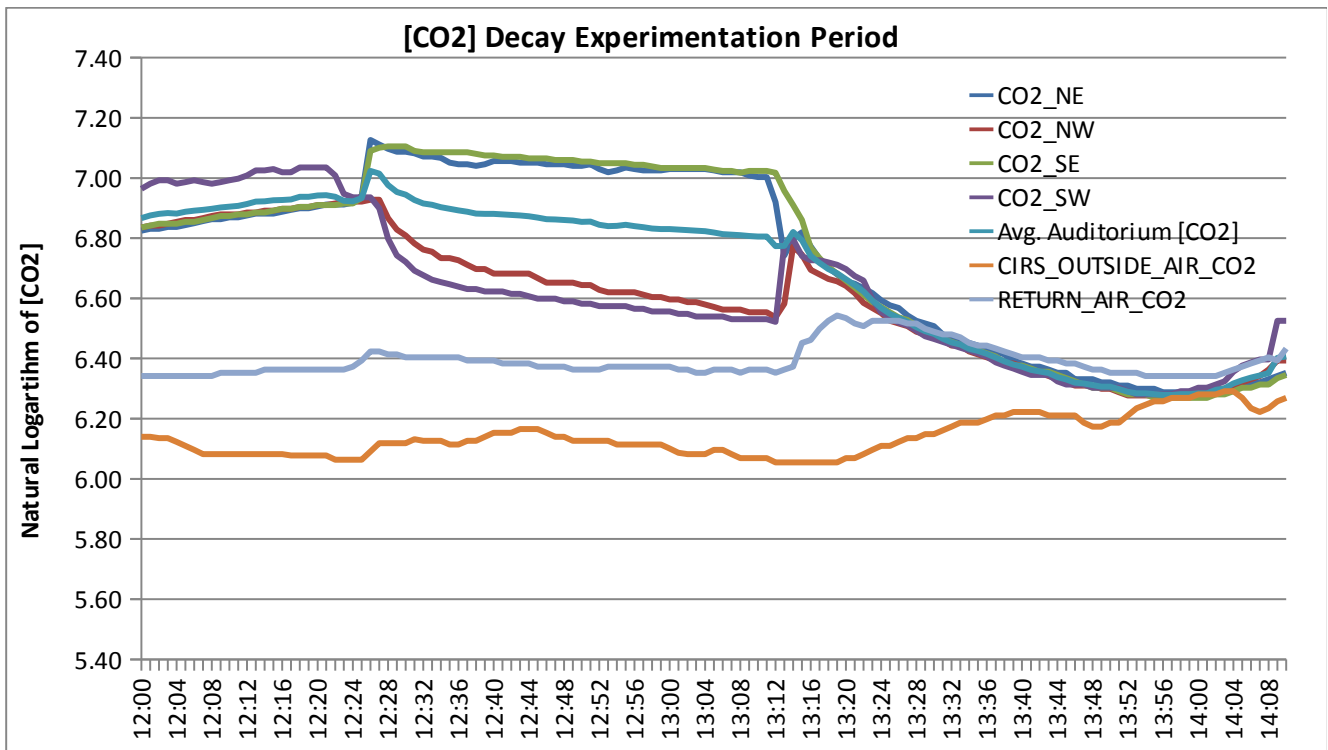

Figure 08: Overview of CO2 Concentration Decay Over Experimentation Period

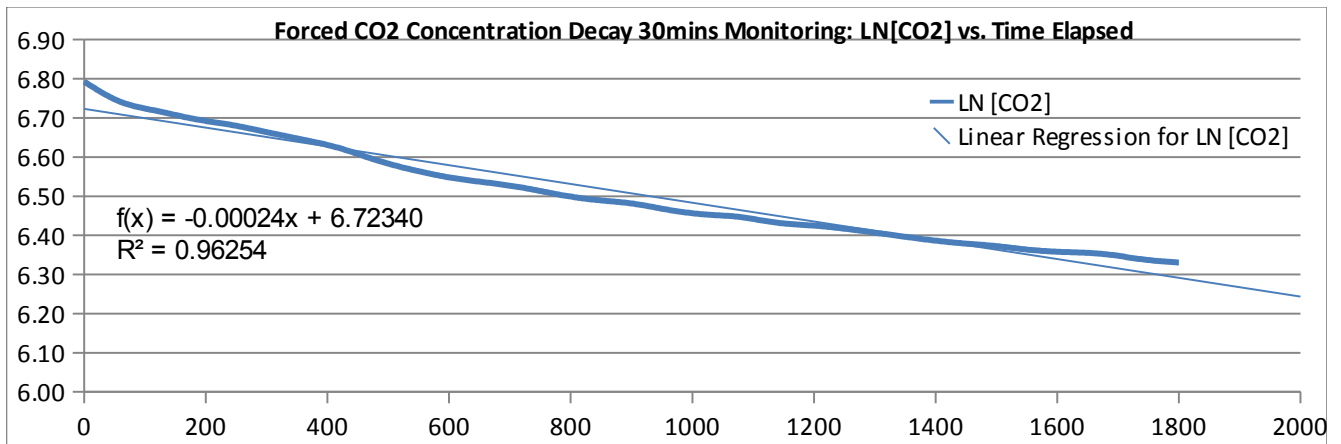
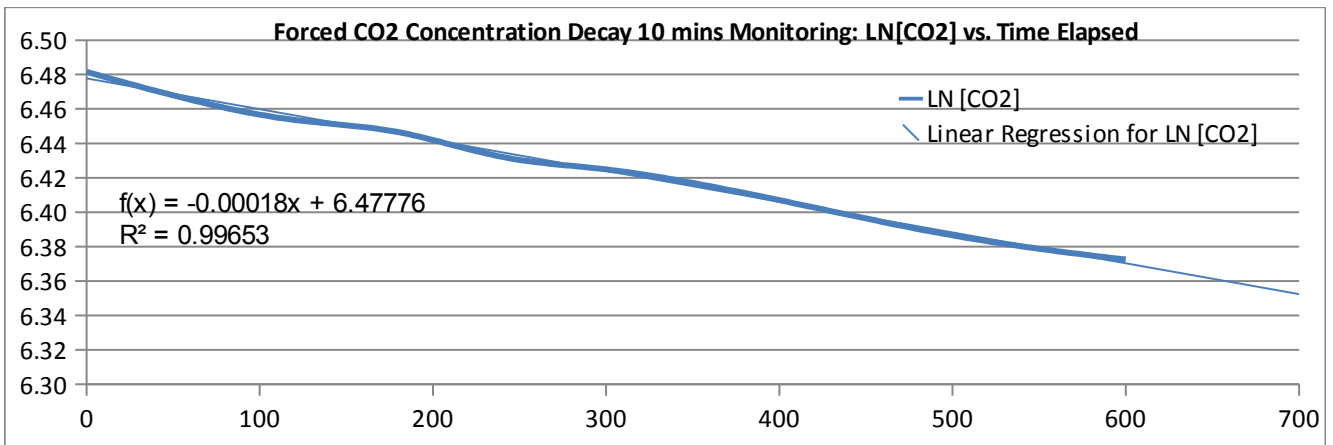

Figure 09: Forced CO2 Concentration Decay Monitoring Over 10min and 30min Period

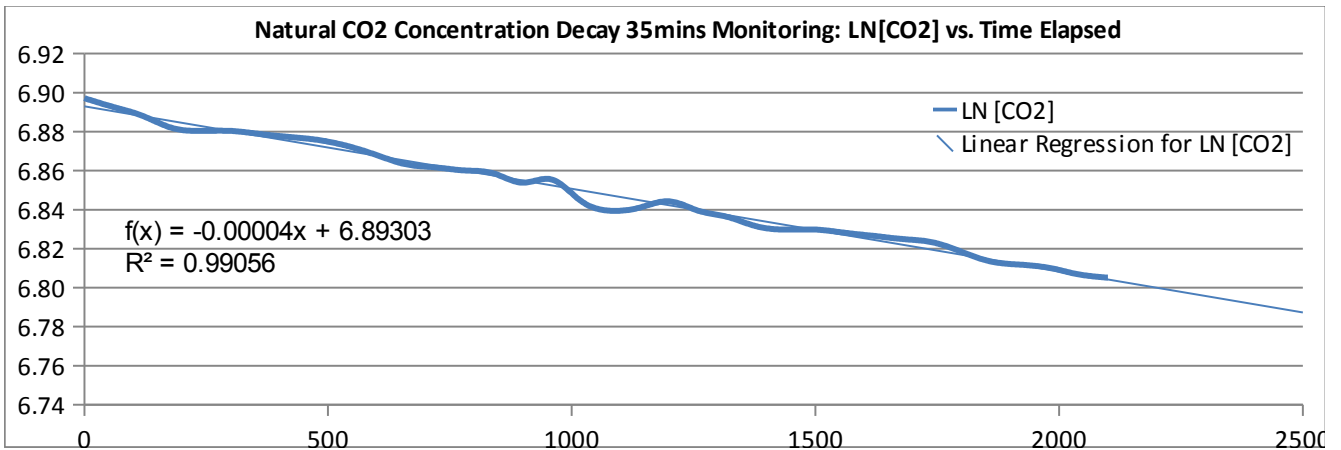

Figure 10: Natural CO2 Concentration Decay Monitoring Over a 45min Period

Air Change Rate Assessment Results through CO2 Concentration Decay Monitoring Methodology					
Assisted Air Change @ Vent. Sys. settings: SF 60Hz RF 54Hz and 50% DP				Natural Air Change/Leaking Enveloppe	
Over 10 min Period (13:30 to 13:40)		Over 30min Period (13:15 to 13:45)		Over 45min Period (13:15 to 13:45)	
Air Change (1/s)	Air Change (1/h)	Air Change (1/s)	Air Change (1/h)	Air Change (1/s)	Air Change (1/h)
1.80E-004	6.48E-001	2.40E-004	0.86	4.00E-005	0.14
>93% Uncertainty		>93% Uncertainty		Unknown	
580L/s Corresponding OA Flow		770L/s Corresponding OA Flow		130L/s Corresponding Leak Flow	
14% of Air Supplied		18.3% of Air Supplied		NA	

Table 16: ACR Assessment Results through [CO2] Decay Monitoring Methodology

Figure 07 is self-explanatory, however what is interesting to note is the stratification of the air within the auditorium as clearly revealed by the CO2 curves that deviate from one another when the ventilation system is turned off and that merge when it is turned back on.

During the CO2 accumulation phase the CO2 concentration is always higher in the South West part of the auditorium. The fact that higher CO2 level are observed in the West can be clearly explained by the preference of students to sit closer to the front of the class. Why the South side is concerned can hardly be explained but one can assume a higher density of students on this side.

Another observation that can be made is the CO2 levels that are actually lower at the front of the class (NW and SW) than at the back when the ventilation system is turned off, despite the fact that most of the CO2 was generated by the student in the West. Here is a possible explanation: air is forced into the auditorium by the ventilation system from East to West and returned to the system at the west (the front of the class). When the system is turned on, the CO2 generated by the students (in majority sitting at the front of the class) has a tendency to diffuse from high concentration areas to low ones (despite a higher density than air and the elevation) but when it does so, it encounters resistance from the forced air flow coming in the opposite direction and preventing its diffusion (sensors in the East will have a greater tendency to measure CO2 levels from the fresh air). As a result there is a stagnation of the CO2 at the front of the class and an accumulation until it is reabsorbed by the system.

The auditorium is part of a larger system which is the CIRS building and which is ventilated by its own independent system (AHU1). Ventilation systems are designed in such a way to maintain a positive pressure within the ventilated system, to avoid non-preheated infiltrations of the air from the outside which is usually cold. When the auditorium ventilation system (AHU2) is turned off the pressure within the building becomes higher than within the auditorium. Air has a tendency to leak in from the inner building to the auditorium and than out again (both building air pressure and auditorium air pressure remain higher than the atmospheric pressure). The doors of the auditorium are located West and this is where the major leakage from the building to the auditorium occurs. This leaking air from the building will therefore push the existing auditorium air East. The behavior is illustrated in the following figure.

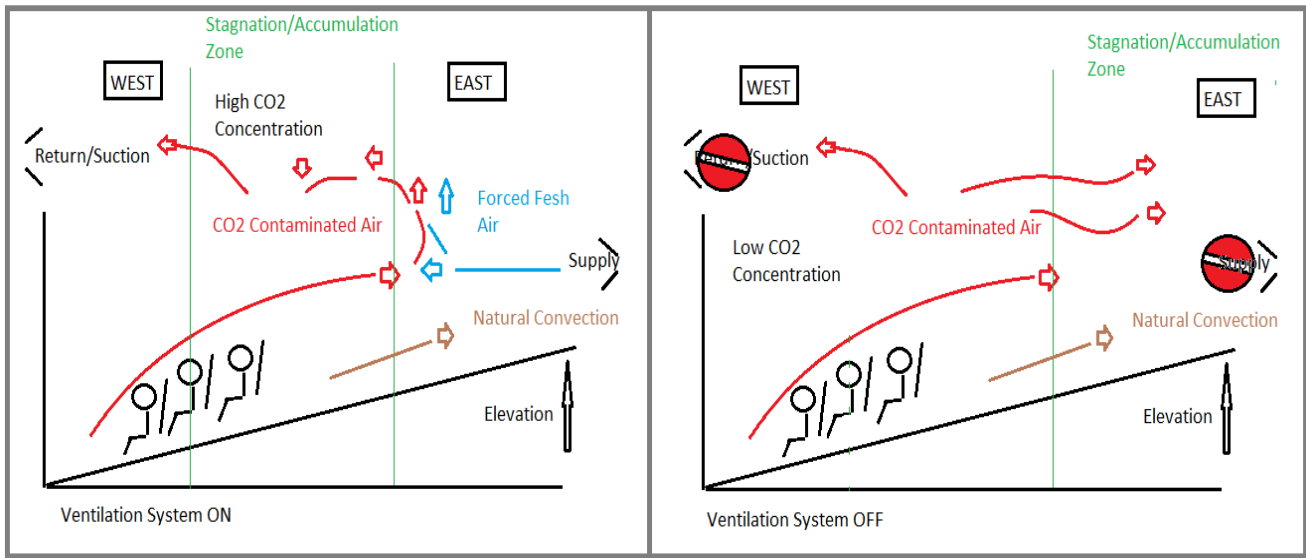

Figure 11: Stratification of the Air in the Auditorium Explanation

The natural decay due to leaking is quite considerable this is due to the fact that the auditorium despite being isolated is no completely air tight and as has previously been discussed receives leaking air from the building interior itself. The building is mechanically ventilated by AHU1 so even when AHU2 is shut off it partially benefits from a mechanically supported air renewal. In other words the decay is more important that if only leaking to the outside was relied upon.

The ventilation system plays an important role in mixing the air and thus achieving uniform conditions within the auditorium. The trends plotted for the concentration decay are satisfactory and show an expected behavior which is well represented by the associated linear regressions.

There is a large difference in the results obtained from both methods at the time being it is therefore hard to conclude despite that the CO2 decay method would be deemed more adequate in this situation. Despite the discrepancy in the results from both methodologies, everything is presented as calculated and analyzed.

### c) Energy Consumption

A major difficulty was encounter while dealing with this part of the project. The program written to analyze the data was designed in a way to refrain from calculating the energy input to the supply air when the system is turned off. Results were obtained but didn't make sense at all. After thorough revision it was noted that the heating valve position sensor readings of AHU2 coil could not be relied upon to determine weather heating is occurring or not. Most of the time the heating was enabled but the valve appeared to be closed giving a false indication that no heating was occurring. The data had to be reprocessed again for the 14 experiments on a very short notice.

The energy related results for the second experimentation series are presented in this section and the related graphs and trends can be found in the appendix section. A analysis integrating the numerical tables and graph is performed to deduce the important points.

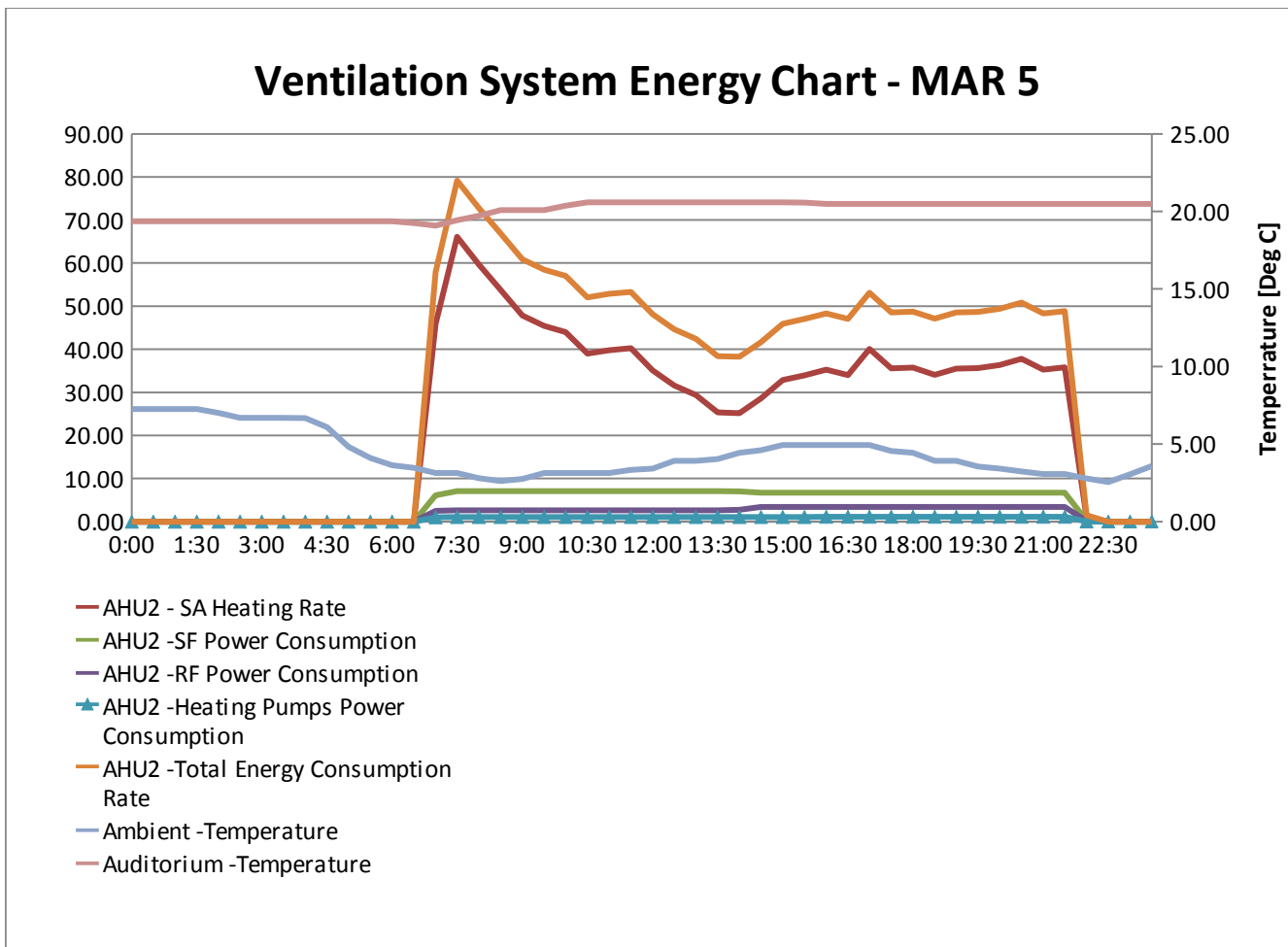

Figure 12: Typical AHU2's Energy Consumption Behavior – Reference Experiment March 5



Numerical Energy Absolute Value Analysis for Test Period 2								
Parameter		T2:Exp1	T2:Exp2	T2:Exp3	T2:Exp4	T2:Exp5	T2:Exp6	T2:Exp7
<b>Average Auditorium Temperature</b>	Average	20.5	20.5	20.6	20.8	20.6	20.8	19.2
	Min	20.1	20.5	20.5	20.3	20.3	20.6	19.2
	Max	20.6	20.5	20.9	21.3	20.7	20.9	19.2
<b>Delta T: Auditorium - Ambient</b>	Average	16.7	17.2	15.1	14.0	13.9	15.6	14.5
	Min	15.5	15.7	13.0	11.4	13.7	14.5	13.1
	Max	17.5	18.3	17.3	16.0	14.3	16.6	16.5
<b>Aud. Temp Change Rate (deg C/h)</b>	Average	0.06	0.00	0.05	0.07	0.05	-0.03	0.00
	Min	-0.30	0.00	-0.05	-1.50	-0.11	-0.35	0.00
	Max	1.51	0.00	1.20	1.51	1.17	0.04	0.00
<b>Heating Rate of AHU2 SA (Kw)</b>	Average	35.59	3.25	4.16	8.19	43.91	6.46	13.65
	Min	25.20	0.00	0.00	0.00	38.92	0.00	6.97
	Max	47.83	10.73	9.57	17.75	47.87	13.63	26.62
<b>SF Power Consumption of AHU2 (Kw)</b>	Average	7.01	0.50	6.94	2.14	6.79	6.44	6.64
	Min	6.70	0.50	6.90	2.10	6.71	6.10	6.60
	Max	7.10	0.50	7.00	2.50	6.80	6.60	6.80
<b>RF Power Consumption of AHU2 (Kw)</b>	Average	2.78	0.30	3.67	1.66	3.32	3.17	2.77
	Min	2.60	0.30	3.50	1.30	3.30	2.90	2.60
	Max	3.40	0.30	3.90	1.70	3.56	3.30	3.40
<b>Heating Pumps Pow. Con. (Kw)</b>	Average	1.08	1.13	1.07	1.12	1.11	1.10	1.11
	Min	1.08	1.12	1.04	1.12	1.09	1.09	1.11
	Max	1.09	1.15	1.13	1.12	1.12	1.12	1.11
<b>Total Energy Consumption Rate (Kw)</b>	Average	48.64	9.48	17.41	17.86	57.14	19.42	26.79
	Min	38.25	6.24	13.19	9.66	51.98	12.96	20.12
	Max	60.88	16.93	22.88	27.41	61.12	26.57	39.76

Table 17: Numerical Energy Absolute Value Analysis for Test Period 2

Numerical Energy Deviation Percentage From Average Analysis for Test Period 2									
Parameter		T2:Exp1	T2:Exp2	T2:Exp3	T2:Exp4	T2:Exp5	T2:Exp6	T2:Exp7	Avg
Average Auditorium Temperature	Average	0%	0%	1%	2%	1%	2%	-6%	20.4
	Min	-1%	1%	1%	0%	0%	2%	-5%	20.2
	Max	0%	0%	2%	4%	1%	1%	-7%	20.6
Delta T: Auditorium - Ambient	Average	9%	13%	-1%	-8%	-9%	2%	-5%	15.3
	Min	12%	13%	-6%	-17%	-1%	4%	-6%	13.9
	Max	5%	10%	4%	-4%	-14%	0%	-1%	16.6
Aud. Temp Change Rate (deg C/h)	Average	99%	-100%	88%	149%	81%	-216%	-100%	0.0
	Min	-9%	-100%	-84%	353%	-66%	6%	-100%	-0.3
	Max	94%	-100%	55%	94%	51%	-94%	-100%	0.8
Heating Rate of AHU2 SA (Kw)	Average	116%	-80%	-75%	-50%	167%	-61%	-17%	16.5
	Min	148%	-100%	-100%	-100%	283%	-100%	-31%	10.2
	Max	92%	-57%	-61%	-29%	93%	-45%	7%	24.9
SF Power Consumption of AHU2 (Kw)	Average	35%	-90%	33%	-59%	30%	24%	27%	5.2
	Min	32%	-90%	36%	-59%	32%	20%	30%	5.1
	Max	33%	-91%	31%	-53%	28%	24%	28%	5.3
RF Power Consumption of AHU2 (Kw)	Average	10%	-88%	45%	-34%	32%	26%	10%	2.5
	Min	10%	-87%	48%	-45%	40%	23%	10%	2.4
	Max	22%	-89%	40%	-39%	27%	18%	22%	2.8
Heating Pumps Pow. Con. (Kw)	Average	-2%	2%	-3%	2%	1%	0%	1%	1.1
	Min	-1%	3%	-5%	3%	0%	0%	2%	1.1
	Max	-3%	2%	1%	0%	0%	0%	-1%	1.1
Total Energy Consumption Rate (Kw)	Average	73%	-66%	-38%	-36%	103%	-31%	-5%	28.1
	Min	76%	-71%	-39%	-56%	139%	-40%	-8%	21.8
	Max	67%	-54%	-37%	-25%	67%	-27%	9%	36.5

Table 18: Numerical Energy Deviation Percentage From Average Analysis for Test Period 2

Comments will be made with respect to experiments individually and in relation with other experiments. Lessons learned from on experiment and mentioned will not be repeated for the other experiments. The following paragraph can accustom the reader to integrate the graphical and numerical results and draw his own conclusions. The paragraph can serve as commenting and analysis protocol.

On the 5<sup>th</sup> of March when the reference day experiment was performed, a peak heating load can be observed at 6:30 Am ([graph for the whole day: Ventilation System Energy Chart March 5](#)); this is when the ventilation system is turned on. The peak is explained by a reaction of the control system to the detection of a low temperature in the auditorium which cools down from 20.5 to 20.1 over night ([Table 17 and Appendix 43](#)). Over night, the ventilation system is shut off, however, despite the fact that the dampers are closed to keep the hot air in, heat leaks through the building envelope and along some air leaks. The peak load represents about 20% of the average heating load for the occupation period. The slope of the heating curve is the highest at this point.

The rate of change of the temperature of the auditorium is 1.31 degrees per hour compared to an average of 0.06 degrees per hour (It is 18X the average rate of change. Note the average is low because there are positive and negative rates during the test period - [Table 17](#)).

At 7:30am the heating rate significantly drops down twice slower than the heating (-0.3 degrees per hour) and classes start 1h30min beyond this time which would have given the system plenty of time to reach the required temperature more smoothly and progressively. From 9:00 to 14:00 the heating rate continues to drop which is due to the fact that the auditorium is occupied and occupants are losing body heat (less heating is necessary from the system since occupants are doing its job unwillingly). The occupation can be noticed from the occupation curve of the testing period [Air Quality Graph](#) or the increase in the CO2 concentration level in the [Auditorium \[CO2\] Distribution – MAR 5](#). The heating stabilizes itself when occupation is at the lowest around 100 persons and stops when the system is turned off at 22:00.

As can be noticed during an experimentation day, energy consumption of the other elements of the ventilation system is pretty much constant. The total energy consumption of the ventilation system fluctuates with the addition of the heat to the supply air.

[Table 18](#) is more convenient to read when it comes to comparing the experiments with one another since it shows how much a certain parameter changes with respect to the average of all experiments for this given parameter. Due to the formatting limitations of open office, please read the same tables included in the appendix formatted using Microsoft words ([Appendices 40 and 41](#)).

Comparing this experiment with the others. It can be seen from [Table 18](#) that the reference day has the second highest energy consumption (73% above the overall average) after experiment 5. The reason is pretty obvious, in the reference day no energy saving measures are implemented. The reason why the system consumed more on the 5<sup>th</sup> day of experiment of this trial period is explained by the colder ambient temperature on this day by around 2.5 degrees and a superior fresh air intake forced by a 70% OA Damper opening instead of the reference 50%.

The supply fan consumes the most energy on this first day (35% above average). The reason for that is unclear and cannot be isolated. In all the experiments the fan RPM is fixed to a certain value except two of them were it has been reduced by 1/3 and 2/3. The reference day will necessarily have a consumption higher than those two experiment days but: what about the other days? The energy consumption of the supply fan is dictated by its RPM and the effort it needs to reach this RPM. The denser the air the more resistance to rotation is encountered. There are two factors affecting the density of the air: relative humidity and the temperature. A combination of both will dictate the density of the air. Those two parameters at the level of the supply fan are dictated by some many external factors: among those, the amount of fresh air intake, the ambient weather, the occupants and and the amount of heating occurring (and thus the SA temperature).

The heating load is always maximal (in terms of amplitude multiplied by time) towards the end of the day (the sun goes down, it gets colder; the auditorium becomes vacant, no energy addition from human activity)

The overall behaviors of the energy curves are pretty similar (with varying rates of change and amplitudes depending on the conditions) and can be explained by the notions elaborated in this paragraph.

When it comes to comparing the experiments to a normal day of operation such as on March 19 it is noticed that in all experiments during which energy saving measures were implemented the ventilation system's average power consumption is lower (Appendix 56, values for the *Total Energy Consumption Rate* compared to 36.78 Kw average consumption observed on March 19). This is an important result because if this is the case while the environmental comfort (air quality and thermal comfort) is maintained that means that the system can further be tweaked for energy savings while on automatic mode. This will be verified in the results integration section.

It is also noticed that when left on automatic, the energy consumption fluctuates much more; this is due to the variation of the damper positions letting more outside air in (and therefore requiring more heating) or not.

The main reason why the average system's energy consumption rate is higher on March 5 than on March 19 (experimentation 1, reference day) is because the experiment was set for constant flows to be obtained 25% higher than the averages observed during normal days of operation in similar environmental conditions.

Some energy behavioral particularities will be mentioned.

On March 6 (Reduced fans speed to 30% of average 24Hz and 21.6 Hz) due to a lower air circulation and thus fresh air intake, less cold air from the outside needs to be heated. This is clear from 11:00 to 16:00 when the system is overridden. As on the reference day, from 6:30 to 7:30, the heat load peak followed by a decreasing heating rate is explained by the same reason (occupancy), even if some parameters start to be fixed starting from 8:00. When the system is put back on automatic after 16:00 the system reacts abruptly to the vacancy and thus diminishing internal temperature along diminishing ambient temperature (colder at night). On this day the greatest energy savings were obtained (64% less than average) but was the air quality still within acceptable limits? Another source of energy savings: the fans set to rotate at a lower RPM will consume much less energy (the power is proportional to the cube of the speed!). The temperature rate of change is the second lowest (-100%) this is due to less circulation and thus abrupt convection induced temperature changes. The system is less dynamic.

On March 7 very roughly 70% of the air was set to recirculate (30% outside air damper opening). The energetic results as well as energy trends are very similar to that of the previous day's experience. However the energy savings are not as important, the change implemented results in a 38% energy saving with respect to average. The return and supply fans consume 2<sup>nd</sup> most in between all experiments. The reason for that cannot be isolated.

The energy behavior of the system on March 8 is very similar to that of March 6 since the occupancy patterns during the testing period on those two days are alike, (the matching of occupancies was made on purpose through the choice of occurrence of the experiment) ambient conditions don't change much, the major change are the fan speeds set to 2/3 of their respective average speed (such as seen in the 1<sup>st</sup> experiment) instead of 1/3 in experiment 2. The change implemented leads to 36% energy savings and ranks third among all measures. It is worthy to note that this was the coldest day within the testing period, more savings could have been achieved if it was not the case!

On March 9 the amount of fresh air intake was maximized with only 30% of recirculation. The day, in terms of occupancy is comparable to March 7 when fresh air intake was minimized. The energy consumption rate is the highest among all experiments. This experiment day has the particularity of having the most stable energy behavior, basically the systems runs all the time at at high capacity (around 40Kw). Because of the energy involvements, other energy consideration such as human generated heat load and fans power consumption become negligible. The internal temperature is very well maintained, proving the heating capacity of the system is enough for extreme conditions: not only was air in allowed at the highest rate but it was the coldest day of the testing period (along the previous day).

On March 12 the behavior of the energy curves is pretty typical of the other days, the energy savings achieved are considerable (31% of the average energy consumption for all experiments). On this day the fresh air intake was reduced to 20% mechanically but 2 out of 4 windows were opened to compensate for that by preventing a deterioration of the air quality. As will be seen in the following section of the report the air quality was preserved most of the time within an acceptable range.

Apart from the experiments where the fans speeds were reduced, this experiment achieves the lowest rate of fan energy consumption. This procedure is well know in industry: in the absence of VFDs dampers are sometimes closed to a near maximum when fans are started up to reduce the cold start load on their driving motors (for example for an industrial heat blower like the drying machine of a pulp manufacturing company). The measure here is equivalent, it is a quasi full closing of the suction of the fan (sometimes referred to as "suffocating the fan"). The fan has less material to push, as if it was turning into empty space, and thus encounters less resistance to rotation. The decreasing temperature rate of change is the highest among all experiments (-216% of average) this is most likely explained by the fact that air comes into the auditorium just above the temperature sensors (located below the windows opened).

On March 12, one can expect a pretty similar behavior to that of the reference day. The temperature set point of the auditorium was lowered by two degrees (from 21 to 19) and led to 5% energy savings but as will be seen in the following sections, the thermal comfort can easily be affected by such a measure.

## The Fans

Fan consumptions and other related results are located in the table above or in the different trends that can be found in the appendix for the different experiments.

## Heating of the Air

Due to the high flow rate of supply air involved the heating of the air is the most energy consuming process of the system when enabled in winter. Sometimes the heating of the air is not needed, specially when the recirculation if the internal air is high and occupants are relied upon to heat the air with their bodies.

A Calculation sample is shown as how the heating energy consumption is derived.

At 12:30pm on March 5:

Relative Humidity = 0.3  
Temperature In= 14.42  
Temperature Out= 19.21  
Flow= 3990 L/s

so using equation [1] and [2] of the corresponding methodology section the enthalpy of the air prior to the coil and after the coil and its density are:

$$h_i = (1.006 \text{ kJ/kg}^\circ\text{C})(14.42) + 0.3[(1.84 \text{ kJ/kg}^\circ\text{C})(14.42) + (2501 \text{ kJ/kg})] = 772.76 \text{ kJ/Kg}$$

$$h_o = (1.006 \text{ kJ/kg}^\circ\text{C})(19.21) + 0.3[(1.84 \text{ kJ/kg}^\circ\text{C})(19.21) + (2501 \text{ kJ/kg})] = 780.23 \text{ kJ/Kg}$$

$$\rho = (1.205\text{E-}3)(1 + 0.3) / (1 + 1.609*0.3) = 1.06\text{E-}3 \text{ Kg/L}$$

$$\text{So } Q_{in} = (1.06\text{E-}3)(780.23 - 772.76) = 31.6 \text{ Kw}$$

Further comments and trends are made in the common sub-part of this section and other related trends can be found in the appendix.

## Heat Recovery

The amount of heat recovered from the AHU2 exhaust stream could have been readily derived from the available sensors readings. This energy would have been deducted from the actual system's total energy consumption and give a better idea of its actual consumption. Unfortunately, half way through the project execution it was noted that the flow meter for AHU2 exhaust was not calibrated. Ignoring the exhaust air flow renders the knowledge of the energy extracted from the auditorium air impossible. The calculations of energy involvement require precise values for the flow under consideration or would lead to very inconsistent results, the accurate values cannot be obtained by any method in such a short notice. This parameter although considered ended up being dropped. But it was important to mention it.

An attempt was made to obtain those results using manually measured flow with no success. However dealing with this matter pointed out the necessity of installing two sensors that can be useful for other studies involving such consideration. These are relative humidity and Temperature sensors at the HRU outlet and AHU1 outlet.

#### d) Air Quality Assessment Results and Limitations

##### Volatile Organic Compounds Concentration [VOCs]

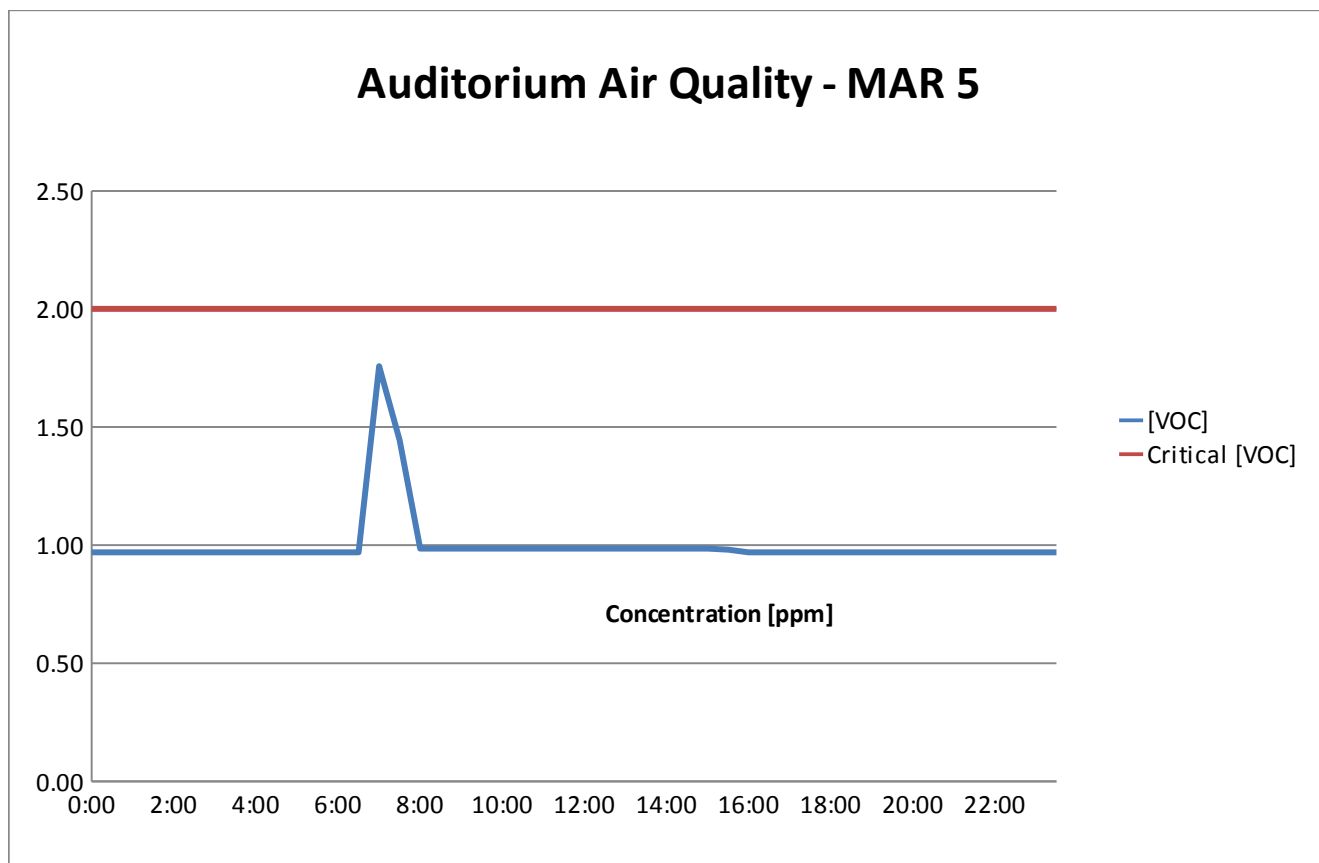

Figure 13: Typical Auditorium Environment VOCs Concentration Behavior – Ref. Exp. March 5

Numerical Absolute VOC Concentrations Level Analysis For Test Period 2									
Parameter		T2:Exp1	T2:Exp2	T2:Exp3	T2:Exp4	T2:Exp5	T2:Exp6	T2:Exp7	
[VOCs]	Auditorium [VOC] in ppm	Average	0.98	0.97	1.01	1.00	0.98	1.07	1.01
		Min	0.97	0.97	0.97	0.98	0.97	0.97	0.99
		Max	0.99	0.97	2.13	1.92	1.00	1.16	1.77
	Average [VOC]	Average	0.00	0.00	-0.17	-0.01	0.00	-0.03	0.11
	Change Rate (ppm//h)	Min	-0.05	-0.01	-3.47	-0.13	-0.08	-0.58	0.00
		Max	0.00	0.00	0.00	0.00	0.00	0.00	2.34

Table 19: Numerical Absolute VOC Concentrations Level Analysis For Test Period 2

The assessment of the adequacy of the ventilation system, in terms of preserving the living space provided by the auditorium from dangerous levels of VOCs concentrations, can be done in a very straight forward fashion. A quick look at the different Air Quality graphs included in the appendices can show if whether critical VOCs level are reached to what extent and when. Some explanation are provided.

With regards to this matter, the following conclusion can be drawn from the relevant literature review: *No standards have been set for VOCs in non industrial settings*. In fact, a recent review concluded that no scientifically valid guidance could be given with respect to indoor TVOC levels (Anderson et al., 1997). There are thousands of VOC compounds. Some of the compounds have been recognized as a specific health risk and have specific guidelines. An example of such specific guideline: The Occupational Safety and Health Administration (OSHA) regulates formaldehyde, a specific VOC, as a carcinogen; it has therefore a Permissible Exposure Level (PEL) of .75 ppm, and an action level of 0.5 ppm. For BC, some of those guidelines for specific compounds (or groups of compounds) can be found in *Exposure Guidelines for Residential Indoor Air Quality; A Report of the Federal-Provincial Advisory Committee on Environmental and Occupational Health*. There are, however, possible benefits to be derived from keeping exposures to airborne contaminants “As Low As Reasonably Achievable.” This ALARA principle suggests that indoor concentrations of VOCs in residences should not exceed levels typically encountered in the housing stock (ECA-IAQ, 1997). The database of TVOC concentrations in residences is limited, and many of the methods used to quantify TVOC are not directly comparable (Hodgson, 1995). Nevertheless, the reported TVOC concentrations for various indoor environments are frequently about 1 mg/m<sup>3</sup>, or lower (Brown et al., 1994).

For the CIRS auditorium a value of 2ppm is chosen as a threshold of VOC concentration that is not to be exceeded; this value is arbitrary and results from common practice rather than solid scientific evidences. An example of such common practice: when the USEPA built their own building, they used a Maximum Allowable Air Concentration Standard of <0.20 mg/m<sup>3</sup> Total Volatile Organic Compounds (TVOCs).

Looking at those graphs some major observations can be made:

- The VOCs concentration are independent of the auditorium occupation level during the testing period.
- Critical Levels of VOCs concentration are never reached when the auditorium is occupied.
- VOCs levels are pretty stable along the day, no significant fluctuations are recorded.
- A VOC concentration surge is recorded everyday during the start-up of the ventilation system that last for one to two hours.



The first observation is quite surprising since it was expected that the VOCs concentration would behave in the same way the CO<sub>2</sub> concentration would. The reason for this not happening is worth investigating in further studies. Even by increasing the resolution of the trends, no elevation of VOCs concentration was spotted at time of high occupancy as was noticed for the CO<sub>2</sub> concentration. However an expected behavior of the VOCs concentration levels was observed on March 21 and 22 where it can be clearly seen that they vary along occupancy.

At night the ventilation system is turned off and the dampers, in closed positions, prevent outside air from infiltrating the auditorium. Apart from very minor air leaks, air circulation and renewal is negligible. VOCs emanate from various elements within the auditorium (or any system), such as the paint of the walls and other furniture, the plastic of some electrical devices, the seats lining and many other objects... The absence of air circulation/renewal allows the VOCs to build up within the auditorium. The VOCs diffuse within the auditorium with unknown uniformity. The VOCs sensor is located within the return/exhaust duct of the ventilation system. The stagnation of the air is such that the sensor does not detect the diffusing VOCs. As soon as the ventilation system is activated air is sucked from within the room, in other words the VOCs spread all over the auditorium is gathered by the suction forces, forced into the return duct and therefore detected by the sensor. The sensor will keep on detecting high levels of VOCs up until most of it has been cleared out from the space. The clearing of the auditorium from VOCs will occur progressively depending on the fresh air intake and fans speed. Until the clearing occurs, the levels of VOCs can be deemed unsuitable for human presence.

An individual and detailed assessment of each experiment is not necessary but an overview will be made along some comments.

- On March 5 and 13, a very typical behavior is observed: all criterion described above are met.
- On March 6, 8 and 9 all criterion described above are met but another surge is observed at night though the ventilation system is turned off.
- On March 7 all criterion described above are met but another surge is observed at night though the ventilation system is turned off. The start-up surge is followed by another one. The reason behind the double surge has not been identified. The critical VOCs level is reached and occupants have most likely (one cannot claim this due to a limitation that is going to be mentioned later on in this section), on that day, been very briefly exposed to critical a VOC level (2ppm at 9:00). The fresh air intake reduced to a minimum have prevented an adequate renewal of the air within the auditorium prior to occupation. On this day the highest positive rate of change of VOCs concentration levels is detected among all experiments (50% above average), in other words the quickest VOC buildup in the return duct during the activation phase of the ventilation system. Air passes through the duct at a normal rate (the fan speeds are normal) but nearly all the air comes from the auditorium and very little from outside.

- On march 12 an unusual behavior of the VOCs concentration level is observed. There is the usual start-up surge but the concentration drops to a higher than usual level, is maintained for about 5hours before reaching the usual value of about 1ppm. On this day the mechanically driven fresh air intake has been reduced to a maximum and two windows were open. The rate of removal of VOC through the exhaust duct is minor, a big part of it occurs through the windows where there is no sensor. Why this steady state was reach is hard to justify.

While the main requirement (critical level never reached during occupancy)can be deemed as met there are several limitations to this kind of analysis and the reliance of this one sensor located in the return air duct:

- *Not detected doesn't mean not present:* The fact that the sensors is located a bit far away from the auditorium does not mean there are actually no VOCs present. The buildup can be concentrated in the center of the room and not reach the sensor up until air is forced in the return duct.
- *Uniformity not measured:* Due to the presence of only one sensor, the distribution of the VOCs (contrary to that of the CO2) is unknown. One cannot guarantee that if high VOCs level are not detected by the sensor that means there are no high VOCs level. To illustrate this claim, let us imagine several VOC emitting elements (such as a paint aerosols) are carried by a student in his backpack for use after school and introduced in the auditorium. A local region in his very near surrounding will be subject to a higher VOCs level to that of the auditorium but will remain undetected.
- *Exposure to high concentration:* As has been seen in all experiments, the VOC buildup in the auditorium needs time to be cleared out and before steady state is reached. Unless the start up time is adequately chosen, occupants may be exposed to high VOCs levels.
- *Unidentified sources of VOCs:* In several experiments, unexplained VOC surges occurred throughout the night despite the system being shut off. The system may not react fast enough to a random and unpredicted introduction of a VOC emitting element.

## Carbon Dioxide Concentration [CO<sub>2</sub>]

The critical CO<sub>2</sub> concentration for the auditorium is considered to be 1000 ppm. This arbitrary value comes from the wide belief in building management that this is a common practice supported by Ashrae. The ventilation system itself is set, as can be seen in the control strategy section, to maximize the fresh air intake to 100% when the differential CO<sub>2</sub> concentration between the inside and the atmosphere exceeds 750 ppm. Given an average of 400 ppm of ambient CO<sub>2</sub> concentration that is equivalent to a 1150 acceptable indoor CO<sub>2</sub>.

It is widely reported by the technical community involved in indoor air evaluations that the American Society of Heating, Refrigeration and Air Conditioning Engineers (ASHRAE) has a standard of 1,000 ppm CO<sub>2</sub> for indoor spaces. The Standard often cited is ANSI/ASHRAE 62-1989 "Ventilation for Acceptable Indoor Air Quality" (which has since been replaced by ANSI/ASHRAE 62-1999). However, this interpretation is incorrect; the current ASHRAE Standard "Ventilation for Acceptable Indoor Air Quality" (ANSI/ASHRAE 62-1999) does not reference the term "1,000 ppm CO<sub>2</sub>." (Petty, 1989).

The first limitation of relying on such a critical value in assessing the adequacy of the air quality and for building management purposes is that the CO<sub>2</sub> level of 1000 is a guideline for comfort acceptability, not a ceiling value for air quality, it is used as a surrogate for odor causing compounds from human activity that may not be acceptable for human comfort.

The Acceptable Short-Term Exposure Range indoor CO<sub>2</sub> concentration mentioned by *Exposure Guidelines for Residential Indoor Air Quality* is 3500 ppm.

In previously published analyses of the 41-building 1994-1996 USEPA Building Assessment Survey and Evaluation (BASE) data-set, higher workday time-averaged indoor minus outdoor CO<sub>2</sub> concentrations (dCO<sub>2</sub>), were associated with increased prevalence of certain mucous membrane and lower respiratory sick building syndrome (SBS) symptoms, even at peak dCO<sub>2</sub> concentrations below 1,000 ppm (Erdmann, C. A., Steiner, K. C., & Apte, M. G., 2002). This statement confirms the limitation of such a reliance. On top of this SBS and mucus problems related to indoor CO<sub>2</sub> concentration are dependent on many factors such as age, sex, smoking status, presence of carpet in workspace, thermal exposure...

## Auditorium [CO2] Distribution - MAR 5

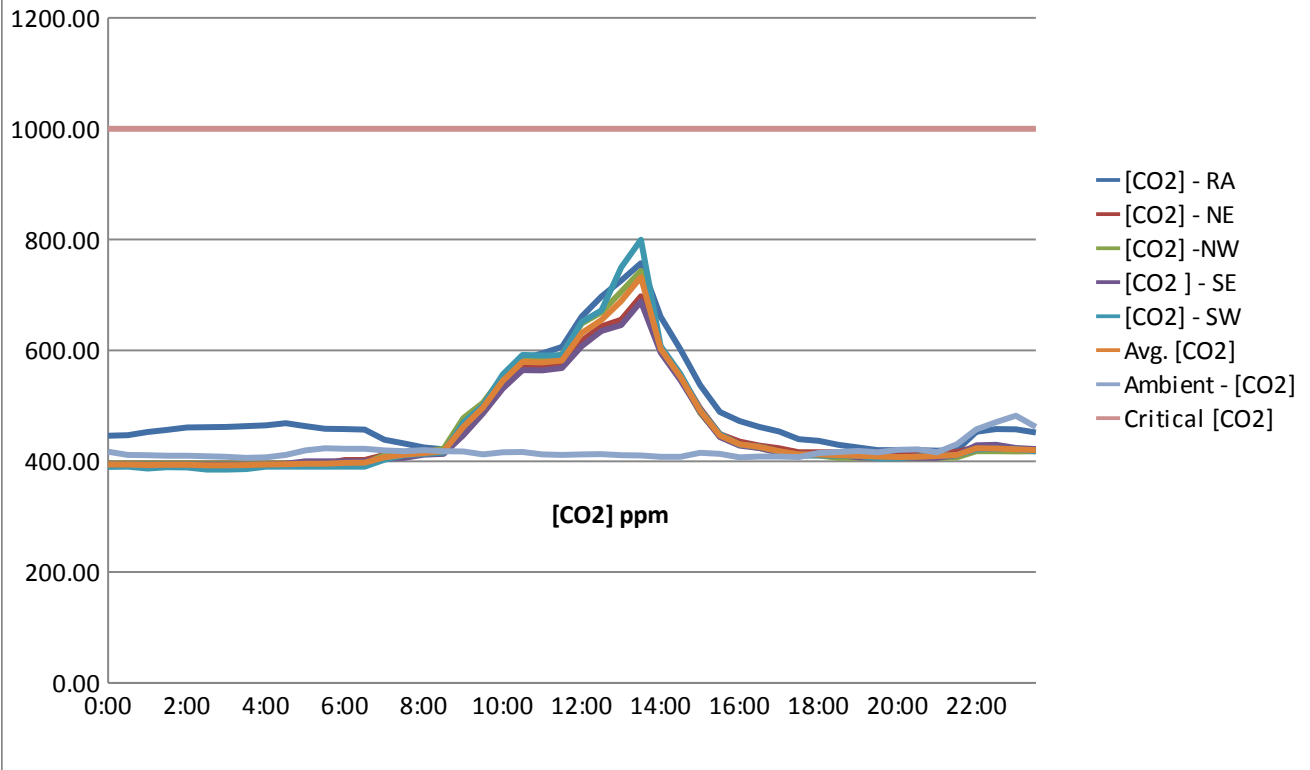

Figure 14: Typical Auditorium Environment CO2 Concentration Behavior – Ref. Exp. March 5

Numerical Absolute CO2 Concentrations Level Analysis For Test Period 2								
Parameter		T2:Exp1	T2:Exp2	T2:Exp3	T2:Exp4	T2:Exp5	T2:Exp6	T2:Exp7
Average [CO2] Change Rate (ppm/h)	Average	2	74	17	40	2	13	8
	Min	-271	-446	-333	-395	-144	-450	-356
	Max	274	526	405	600	113	455	405
Average Auditorium [CO2]	Average	574	940	762	723	512	741	649
	Min	429	423	472	451	463	496	440
	Max	761	1329	1053	994	577	1035	734
Delta [CO2]: Auditorium – Ambient	Average	162	507	246	241	43	332	203
	Min	11	-22	0	-25	-30	84	-50
	Max	353	904	564	524	108	629	322
Delta [CO2]: NW - Auditorium	Average	8	-62	1	-32	-3	-5	-10
	Min	-15	-137	-19	-86	-21	-25	-32
	Max	70	52	34	27	18	34	28
Delta [CO2]: NE - Auditorium	Average	-8	-64	-14	-31	-7	-7	-19
	Min	-71	-148	-64	-89	-29	-29	-44
	Max	11	36	6	27	5	14	18
Delta [CO2]: SW - Auditorium	Average	17	187	32	96	22	25	56
	Min	-15	-80	0	-12	3	-2	-7
	Max	107	411	126	254	93	83	119
Delta [CO2]: SE - Auditorium	Average	-16	-61	-19	-34	-12	-13	-27
	Min	-79	-157	-70	-91	-43	-39	-52
	Max	3	22	3	8	-1	-1	10
Delta [CO2]: RA - Auditorium	Average	27	-165	-146	-45	71	-92	19
	Min	-18	-312	-350	-286	-13	-305	-36
	Max	72	8	24	47	137	40	58
Total	Average	6	-31	-30	-16	15	-21	5
	Min	-79	-312	-350	-286	-43	-305	-52
	Max	107	411	126	254	137	83	119

Table 20: Numerical Absolute CO2 Concentrations Level Analysis For Test Period 2

An overview of the behaviors of the CO2 concentrations for the different experiments will be made along some supporting explanations. Two factors will be considered: the first one being whether critical levels are reached, the second will be an assessment of the uniformity of the CO2 distribution within the auditorium. Two elements can help spot non uniformity: a significant separation in between the curves generated from the data of the different sensors (graphs), a significant deviation from the average uniformity with respect to the other experiments (from the corresponding tables, the “total” average-min-max).

On March 5, the CO2 concentration levels behavior is pretty typical: piling up with the successive occupancy of the auditorium. The reference experiment has the best uniformity and air mixing among all experiments after experiment 5.

A way to see this is noticing that at most the absolute level in concentration in between the auditorium sensors is 107ppm while the average is 6ppm.

On March 6 the low supply and return ventilation rates (1/3 of normal ventilation rate) do not allow a proper clearing of the CO<sub>2</sub> generated by the students and a proper mixing in the auditorium. The highest non uniformity is witnessed during this day with a 411ppm difference between two of the auditorium sensors and among the highest averages of CO<sub>2</sub> concentration difference between sensors (411ppm). The piling up of CO<sub>2</sub> rate is the second highest among all: 526ppm/hour. High clearing rates are only observed when the system is put back on automatic when the critical CO<sub>2</sub> concentration level has been reached and is therefore not representative (-446ppm/hour) of the experiment itself. On March 12 one can observe similar behaviors since the measures undertaken are equivalent (a reduction of the fresh air intake) despite different occupancies.

On March 7 the low fresh air intake (70% recirculation) also leads to the critical concentration of CO<sub>2</sub> being reached around mid-day but can be deemed acceptable. Surprisingly the return air has much lower concentration levels than the auditorium average despite that the air is properly mixed. This should be understood but no explanation can be thought of with a more in depth study of the matter.

On March 8 and 13 two CO<sub>2</sub> concentration domes are observed on the graphs. They are separated by a certain low occupancy or vacancy period of the auditorium where the system had time to clear out the excess CO<sub>2</sub>. Uniformity is good apart from a deviation of the SW sensor on March 8.

On March 9, the fresh air intake is maximized, the CO<sub>2</sub> barely piles up in the auditorium, the critical level is far from being reached at any point of the auditorium. The uniformity is excellent. The system was put back on automatic after 16:00 an event provoking an unknown occupancy of the auditorium explains the second CO<sub>2</sub> dome on the graph.

The auditorium CO<sub>2</sub> level behavior observed on March 13 is different than the one observed on March 5 despite the similarity in the controlled parameters (the temperature set-point change does not affect CO<sub>2</sub> levels in any way). The reason behind this difference is the varying occupation patterns for both days that are a huge factor in determining how the CO<sub>2</sub> builds up in the auditorium.

### e) Thermal Comfort Assessment Results and Limitations

CIRS Auditorium Thermal Comfort Assessment Table At 1.0 Clo								
From	To	03/05/12	03/06/12	03/07/12	03/08/12	03/09/12	03/12/12	03/12/12
09:00	09:30							
09:30	10:00	Occupancy: 133 RH: 30.4% Temperature: 20.4	Occupancy: 255 RH: 21.3% Temperature: 19.8	Occupancy: 133 RH: 24.3 Temperature: 20.6	Occupancy: 255 RH: 25.3 Temperature: 20.5	Occupancy: 133 RH: 37.3 Temperature: 20.5	Occupancy: 133 RH: 30.4 Temperature: 20.4	Occupancy: 255 RH: 29.7 Temperature: 19.3
10:00	10:30	Occupancy: 257 RH: 30.2% Temperature: 20.5		Occupancy: 257 RH: 25.4% Temperature: 20.6		Occupancy: 257 RH: 38.9 Temperature: 20.6	Occupancy: 257 RH: 30.2 Temperature: 20.5	
11:00	11:30	Occupancy: 202 RH: 29.5% Temperature: 20.6	Occupancy: 227 RH: 23.3% Temperature: 20.5	Occupancy: 202 RH: 35.36% Temperature: 21.50	Occupancy: 227 RH: 27.3 Temperature: 20.8	Occupancy: 202 RH: 39.3 Temperature: 20.7	Occupancy: 202 RH: 29.5 Temperature: 20.6	Occupancy: 227 RH: 31.6 Temperature: 19.4
12:00	12:30	Occupancy: 336 RH: 28.8% Temperature: 20.8		Occupancy: 336 RH: 27.6% Temperature: 20.7		Occupancy: 336 RH: 40.9 Temperature: 20.7	Occupancy: 336 RH: 28.8 Temperature: 20.8	
13:00	13:30	Occupancy: 371 RH: 28.1% Temperature: 20.8	Occupancy: 149 RH: 24% Temperature: 21.1	Occupancy: 371 RH: 29% Temperature: 20.8		Occupancy: 371 RH: 40.7 Temperature: 20.7	Occupancy: 371 RH: 28.1 Temperature: 20.8	Occupancy: 149 RH: 32.6 Temperature: 19.4
13:30	14:00			Occupancy: 316 RH: 24.1 Temperature: 21.4		Occupancy: 135 RH: 28.8% Temperature: 20.7	Occupancy: 316 RH: 28 Temperature: 20.6	
14:00	14:30	Occupancy: 135 RH: 25.5% Temperature: 20.6						Occupancy: 316 RH: 33.7 Temperature: 19.5
14:30	15:00							
15:00	15:30					Occupancy: 103		
15:30	16:00					RH: Na		
16:00	16:30					Temperature: Na		
16:30	17:00							

**Table 21: Thermal Comfort Assessment Over Testing Period**

Note: Green = Well Within Comfort Zone; Yellow = Comfort Zone Borders/Acceptable; Red=Off comfort Zone

**Results: Differences Analysis – Thermal Comfort Uniformity Indicator**

Parameter		T2:Exp1	T2:Exp2	T2:Exp3	T2:Exp4	T2:Exp5	T2:Exp6	T2:Exp7	
Temperature	Average Auditorium Temperature	Average	20.5	20.5	20.6	20.8	20.6	20.8	19.2
		Min	20.1	20.5	20.5	20.3	20.3	20.6	19.2
		Max	20.6	20.5	20.9	21.3	20.7	20.9	19.2
	Delta T: NW - Auditorium	Average	0.3	0.4	0.3	0.3	0.3	0.2	0.5
		Min	0.2	-0.8	0.0	-0.1	0.2	0.1	0.0
		Max	0.7	0.9	0.8	0.7	0.6	0.5	0.9
	Delta T: NE - Auditorium	Average	0.1	0.3	0.0	-0.2	-0.1	-0.4	0.1
		Min	-0.3	-1.1	-0.3	-0.6	-0.2	-0.6	-0.2
		Max	0.4	1.1	0.1	0.2	0.2	-0.2	0.3
	Delta T: SW - Auditorium	Average	0.3	0.9	0.1	0.5	0.1	0.1	-0.1
		Min	-0.2	-0.9	-0.3	-0.4	0.1	-0.1	-0.5
		Max	1.3	1.7	0.4	1.4	0.5	1.1	0.3
	Delta T: SE - Auditorium	Average	-0.2	0.0	-0.1	-0.3	0.0	-0.3	0.1
		Min	-0.4	-1.2	-0.4	-0.7	-0.1	-0.4	-0.1
		Max	0.1	0.8	0.1	0.1	0.3	0.0	0.1
	Delta T: SA - Auditorium	Average	-0.7	-2.1	-1.2	-2.1	-1.0	-1.4	-3.2
		Min	-2.8	-6.3	-3.2	-6.1	-1.9	-4.1	-5.6
		Max	1.2	2.8	0.4	1.7	0.3	-0.1	-1.7
	Delta T: RA - Auditorium	Average	1.5	1.4	1.4	1.0	1.3	1.1	1.9
		Min	1.0	-0.4	1.0	0.5	0.8	0.4	1.0
		Max	2.0	2.6	1.9	1.8	1.8	2.0	2.4
Total	Average	0.24	0.00	0.06	-0.12	0.18	-0.11	-0.21	
	Min	-2.79	-6.34	-3.23	-6.05	-1.85	-4.06	-5.55	
	Max	2.03	2.80	1.91	1.77	1.80	1.99	2.45	
Relative Humidity	Average Auditorium Relative Humidity	Average	27.9	23.7	26.9	28.2	39.6	35.1	32.4
		Min	22.0	22.0	23.4	24.6	36.3	30.5	28.7
		Max	31.0	24.9	29.6	32.0	41.4	38.6	34.0
	Delta RH: NW - Auditorium	Average	-0.4	-1.1	-0.4	-1.2	-0.5	-1.3	-0.2
		Min	-1.1	-2.2	-1.3	-2.6	-1.7	-2.5	-1.2
		Max	0.1	0.5	0.1	0.1	0.0	-0.4	0.3
	Delta RH: SW - Auditorium	Average	-0.2	1.8	0.1	0.7	0.1	0.3	0.2
		Min	-0.7	0.0	-0.4	-0.3	-0.5	-0.2	-0.3
		Max	0.3	3.5	0.7	1.6	0.8	1.6	0.8
	Delta RH: SE - Auditorium	Average	0.7	-0.6	0.3	0.5	0.4	1.0	0.0
		Min	0.0	-1.5	-0.2	-0.6	-0.3	0.3	-0.5
		Max	1.4	0.2	1.0	1.6	1.4	1.9	0.9
	Delta RH: SA - Auditorium	Average	0.7	4.0	1.8	4.8	2.8	3.5	6.7
		Min	-2.5	-6.2	-1.2	-2.2	0.2	0.3	2.8
		Max	4.2	15.5	5.4	13.6	5.5	9.2	8.9
	Delta RH: RA- Auditorium	Average	2.2	-0.3	-3.1	-0.2	-0.2	-1.4	-1.2
		Min	0.8	-1.5	-5.5	-2.7	-1.2	-3.8	-2.2
		Max	4.2	1.2	-0.3	1.5	0.7	0.7	1.0
	Total	Average	0.6	0.9	-0.2	1.0	0.5	0.6	1.1

**Table 22: Thermal Comfort Uniformity Within The Auditorium Analysis**



The thermal comfort assessment follows the method described in the corresponding methodology section. This is quite a rough estimate, specially that the concept of thermal comfort is ambiguous and subjective. According to the standards previously stated, most of the time, the comfort levels achieved in the auditorium are deemed just acceptable. A raise of two degrees Celsius set point would guarantee thermal comfort according to those standards given relative humidity of 20% to 30.5%.

Depending on the uniformity of the relative humidity and temperature distribution and their combination some locations within the auditorium may easily fall outside the comfort zone.

Other parameters not taken into account do also greatly affect how a person feels when using a given space: the vertical temperature gradient which in this case is not assessed.

For the sake of reference an example will be sited: On the second experimentation day of the trial period 2, the greatest temperature difference between the SW sensor and the average auditorium temperature is 1.7 degrees. While the time of occurrence of this difference is not known (but could be) whenever it falls within the day it would drift the thermal comfort results way out of bounds.

## V- Results Integration, Energy Savings and Optimization Recommendations

The essence of this analysis is to show that even on automatic there is still a possibility of energy savings through measures that do not hinder the livability/comfort of the auditorium space.

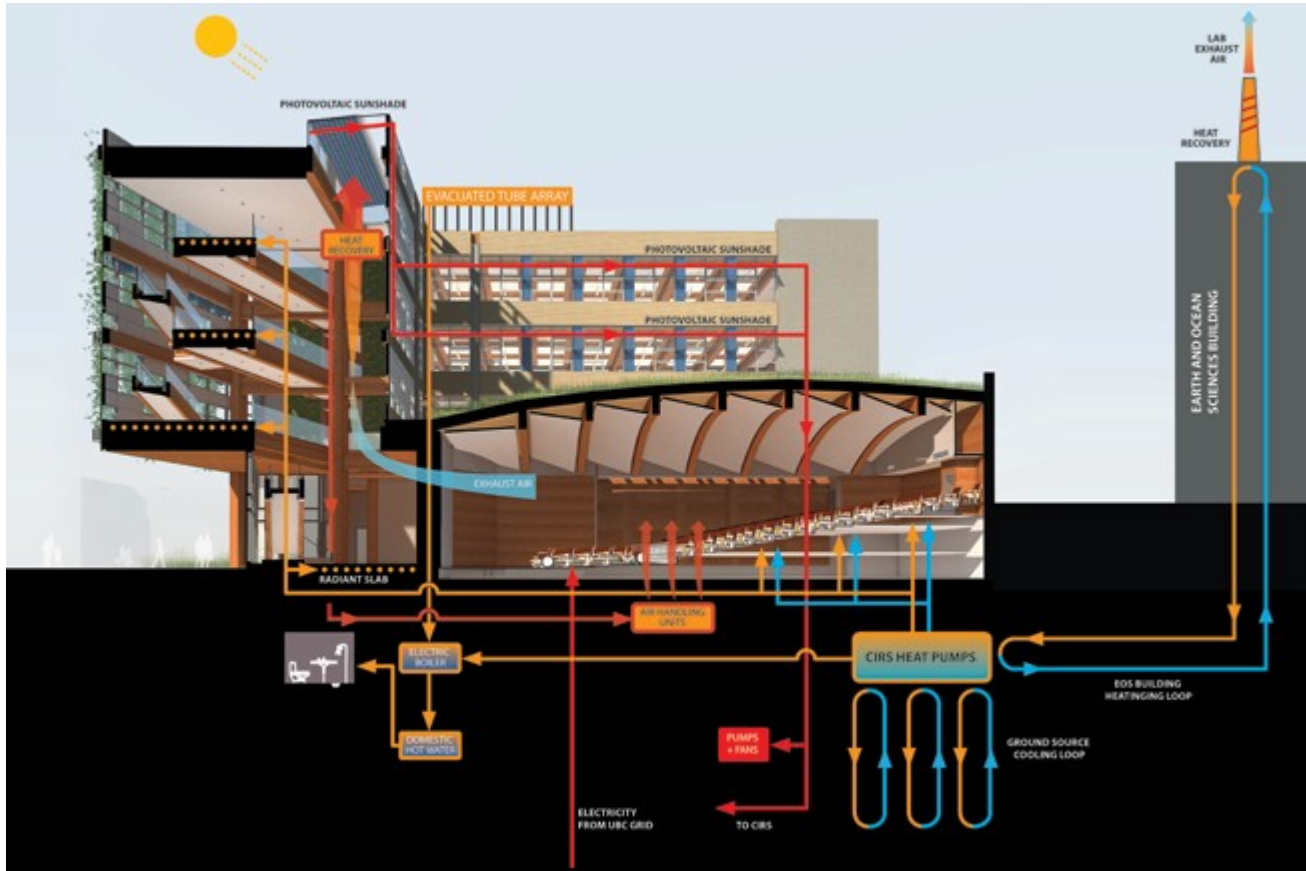

Figure 15: CIRS Energy System Diagram

The CIRS is a complex energy system of which description can be found on the CIRS official site: “Multiple systems work together to serve the different needs in the building and use energy efficiently. A heat recovery system captures waste heat in the exhaust ventilation from the fume hoods on the adjacent Earth and Ocean Sciences (EOS) building and transfers it to the heat pumps in CIRS. The heat pumps provide heating and cooling for the building through the radiant slabs and a displacement ventilation system. The energy exchange system returns excess heat from the CIRS heat pumps to EOS, which reduces its heat load and the demand on the campus steam system. The amount of energy in the heat transferred to EOS is greater than the total amount of energy consumed in CIRS. A ground source geo-exchange field supplements the waste heat recovery and provides heating and cooling to the pumps. An evacuated tube array on the roof that captures solar energy and an internal heat recovery system that captures waste heat from the building systems preheat the domestic hot water. Photovoltaic cells on the atrium roof and the window sunshades convert solar energy into electricity.”

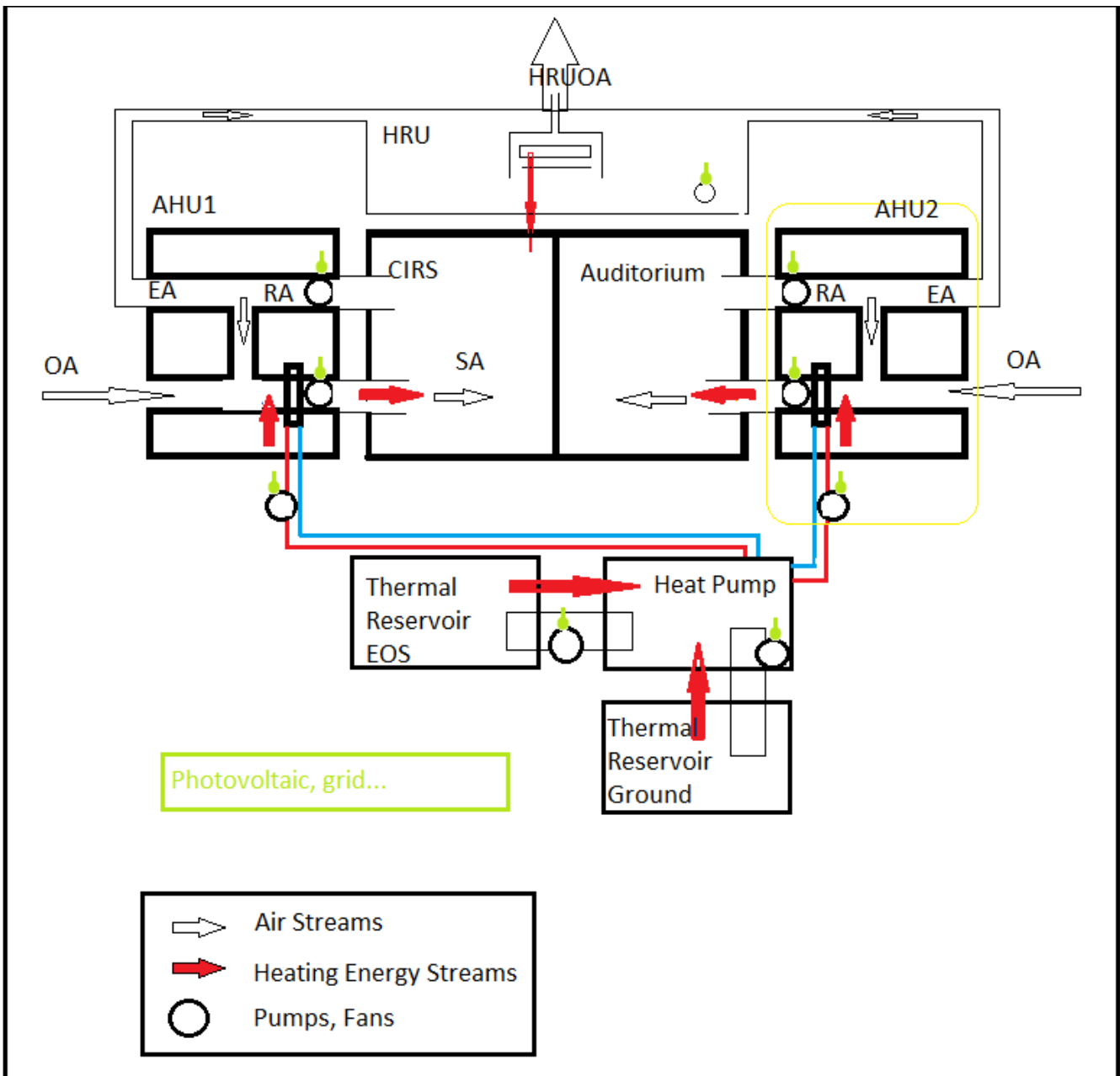

Figure 16: Ventilation System Energy Diagram

Depending on the choice of the system and its boundaries, estimating the savings and environmental impact can be a very difficult task. The AHU under consideration involves 3 types of energy: direct electrical (fans and pumps), indirect electrical (heat pumps: the thermal energy extraction is supported by the compression of the refrigerant which consumes electricity) and thermal (HRU). The energy recovered from the air handling unit is dependent on whether it is needed (the recovery is automatically bypassed otherwise) by the various systems intended to be receiving it. The energy input (and paid for) to heat up the air, is dependent on the coefficient of performance of the heat pump.

The coefficient of performance is dependent on the the temperature difference between the two thermal reservoirs exchanging heat. One of the thermal reservoirs, the EOS building, from which the heat pump extract heat is highly variable (mainly due to its varying occupancy and energy demand). The fans and pumps draw energy which is either supplied by BC Hydro through the UBC grid or by the photovoltaic system installed. The amount of energy paid for is dependent on how much solar power is recovered and therefore the ambient conditions. Most of the energy (90% of it) is supplied by BC Hydro. 90% of BC Hydro's generated electricity is from Hydro power, but given the fact that BC Hydro continuously import (from various origins, fossil and non-fossil) and exports electricity, the actual carbon savings would be hard to precisely predict.

Further clarification will be made to help read the following table, assumption will be stated and system boundary defined:

- The system boundary is illustrated in figure 16 by a yellow line, it includes the AHU2.
- The total energy consumption and savings is both thermal and electrical, it is an aggregate value that includes the thermal energy into the supply air stream, The SF and RF and heating pump electrical consumption.
- The energy being dealt with is absolute and not representative of the energy that is actually paid for (not all the energy inputted to the supply air is paid for due to the COP of the heat pump).
- The reference day is assumed to be representative of a normal day of operation although some control parameters were overridden and fixed\*.
- Energetic operating costs are derived from the average power consumptions measured during a whole daily period of interest (9am to 4pm) for the different systems mentioned for each experiment.
- Savings are obtained by comparing each experiment to the reference day. Setting the system's parameter such as done in the experiments does not guarantee the same savings as they are dependent on many other factors such as ambient conditions, auditorium occupation etc...
- The savings are not adjusted based on outside conditions of temperature and relative humidity. In other words if a hotter day will result in additional savings that are not originating from the control measures taken although expressed by the numerical figures.
- The number given in this analysis are very rough estimates for the sake of illustration and support. In no way are those result claimed to be accurate but rather they are indicative of certain potentials and tendencies aimed at motivating changes in the system's control.
- The energy recovered in the HRU is disregarded since outside of the system boundaries chosen.

*\*While it is true that even on the reference day some parameters were fixed (to reduce the variability preventing comparison) the reference day is still representative of a normal operating day where the system is set to automatic. This is because the fixed parameters are assigned values that are nothing but the average of the respective parameters over a day on automatic mode.*

	Reference Day	Experiment 2	Experiment 3	Experiment 4
<b>Modification</b>	None	65% Fan Speed Reduction	40% Fresh Air Intake Reduction	35% Fan Speed Reduction
<b>Average Power Consumption [Kw]</b>	48.5	9.5	17.5	18
<b>Energy Consumption (over 860h<sup>(1)</sup>) [Kwh]</b>	41710	8170	15050	15480
<b>Estimated Energy Savings Potential % w/r to ref.</b>	0%	80%	64%	63%
<b>Estimated Energy Savings Potential w/r to ref (Kwh over 860h)</b>	0	33540	26660	41692
<b>Estimated Energy Savings Potential % w/r to Auto. Day 1</b>	-31%	74%	53%	51%
<b>Estimated Energy Savings Potential w/r to Auto. Day 1 (Kwh over 860h)</b>	-9890	23650	16770	16340
<b>Air Quality Assessment - VOCs</b>	VOCs concentrations levels remained below the critical value at all time. Max [VOCs] = 0.99 ppm	VOCs concentrations levels remained below the critical value at all time. Max [VOCs] = 0.97 ppm	Minor/brief exposure of student to critical VOCs concentration levels. Max [VOCs] = 2.13 ppm	VOCs concentrations levels remained below the critical value at all time. Max [VOCs] = 1.92 ppm
<b>Air Quality Assessment - CO2</b>	CO2 concentrations levels remained below the critical value at all time. Max [CO2] =761 ppm	Prolonged exposure to above critical CO2 levels at a certain point during the experiment Max [CO2] =1329 ppm	Brief exposure to above critical CO2 levels at a certain point during the experiment Max [CO2] =1053 ppm	CO2 concentrations levels remained below the critical value at all time. Max [CO2] =994 ppm
<b>Thermal Comfort Assessment</b>	RH: 30.2% Temperature: 20.5 from 10am to 11am	RH: 22.3% Temperature: 19.8 from 10am to 11am	RH: 25.4% Temperature: 20.6 from 10am to 11am	RH: 25.3% Temperature: 20.5 from 10am to 11am
<b>Feasibility</b>	Yes	No	Yes	Yes
<b>Recommendations</b>	Increase temperature set point by 2 degrees	Decrease Fan Speeds Less Drastically	A 25% to 30% fresh air intake reduction would be advised	Implement but Increase temperature set point by 2 degrees

**Table 23: Experiments Outcome Summary 1**

	Reference Day	Experiment 5	Experiment 6	Experiment 7
Modification	None	40% Fresh Air Intake Increase	60% Fresh Air Intake Reduction + 50% Window Opening	Temperature Set Point Decrease by 2 degrees
Average Power Consumption [Kw]	48.5	57	19.5	27
Energy Consumption (over 860h <sup>*(1)</sup> ) [Kwh]	41710	49020	16770	23220
Estimated Energy Savings Potential % w/r to ref.	0%	-18%	60%	44%
Estimated Energy Savings Potential w/r to ref (Kwh over 860h)	0	-7310	24940	41683
Estimated Energy Savings Potential % w/r to Auto. Day 1	-31%	-54%	47%	27%
Estimated Energy Savings Potential w/r to Auto. Day 1 (Kwh over 860h)	-9890	-17200	15050	8600
Air Quality Assessment - VOCs	VOCs concentrations levels remained below the critical value at all time. Max [VOCs] = 0.99 ppm	VOCs concentrations levels remained below the critical value at all time. Max [VOCs] = 1.00 ppm	VOCs concentrations levels remained below the critical value at all time. Max [VOCs] = 1.16 ppm	VOCs concentrations levels remained below the critical value at all time. Max [VOCs] = 1.77 ppm
Air Quality Assessment - CO2	CO2 concentrations levels remained below the critical value at all time. Max [CO2] =761 ppm	CO2 concentrations levels remained below the critical value at all time. Max [CO2] =577 ppm	Brief exposure to above critical CO2 levels at a certain point during the experiment Max [CO2] =1035ppm	CO2 concentrations levels remained below the critical value at all time. Max [CO2] =734 ppm
Thermal Comfort Assessment	RH: 30.2% Temperature: 20.5 from 10am to 11am	RH: 38.9% Temperature: 20.6 from 10am to 11am	RH: 30.2% Temperature: 20.5 from 10am to 11am	RH: 29.7% Temperature: 19.3 from 10am to 11am
Feasibility	Yes	Unnecessary	Yes	No
Recommendations	Increase temperature set point by 2 degrees	Fresh air increase is only advised momentarily when critical levels of air quality are reached	This measure can be resorted to but leads to less uniformity.	The temperature is not recommended to be decreased.

Table 24: Experiments Outcome Summary 2

<sup>\*(1)</sup>860 hours represent the approximate amount of hours that the ventilation system is active during one academic semester (4 month, 5 days a week, 10 hours a day)

The green color indicates that the measure implemented to reasonable extents shouldn't be source of concern when it comes to the adequacy of a certain parameter. The yellow color indicates that the conditions were still overall acceptable according to criteria with minor exceptions but may drift away if some conditions that are not controlled favor the drift. The orange color shouldn't be source of worrying, but rather an indication that extra attention should be given when interpreting the results and the limitations should clearly be identified in order not to classify an acceptable environment as bad one. A very simple modification can drastically affect the result: For example in experiment 3 the orange color should not be interpreted as indicative of a big problem that makes the measure (the reduction of fresh air intake non viable) non viable.

A slight increase in the temperature set point would make the conditions adequate according to the criterion followed for thermal comfort while not hindering too much the energy savings obtained thanks to the measure implemented.

Overall, the results show that saving measures can be implemented through the tweaking of the control algorithm linking the different parameters of the ventilation system.

The results of experiment revealed some drifting with regards to the CO<sub>2</sub> and thermal comfort criteria, it wouldn't be recommended to set the system to obtain such a low air circulation despite the appealing energy savings. A less drastic measure implementation similar to this one is seen in experiment 4 would be recommended. In other words modify the control parameters of the system in such a way that the average circulation flow is decreased. Experiment 3 is comparable to experiment 4 when it comes to energy savings, while not too bad when it comes to environmental adequacy. However the results should be interpreted as such that if the choice is available one should rather opt for the decrease in circulation. Experiment 6 shows that opening windows can be a good substitute to mechanically forcing outside air in it is a less severe measure than the one adopted in experiment 3 and makes it more feasible. Experiment 7 is representative of the order of magnitude of savings one would obtain by decreasing the temperature set point. The deviation from the thermal comfort criterion does not indicate that such measure is inadequate, but rather that the temperature set point was already appropriately chosen and didn't need further modification.

One should be careful when reading and interpreting those results. As has been previously discussed there are limitations to relying on solely those criteria and methodologies. The table simply summarizes what was observed, more through interpretations of the results will be subject to fallacies and therefore left to the reader's discretion. To illustrate what has been said some example are taken. For experiment 3, at some point during the day, the conditions were such that when plotted on a psychometric chart the point fell outside the comfort box defined by Ashrae. The experiments fail to pass this specific criteria but does that mean the environment is inadequate when it comes to CO<sub>2</sub> concentrations? Not really because the criteria has a lot of limitations and the methodologies relied upon are broad. What the criteria aim to achieve is to guarantee in certain ways that if the conditions are such that the criteria are met it is most likely that the conditions should not be perceived by an overwhelming majority of people as problematic.

## **VI- Conclusion**

The study has shown the advantages of dealing with a modern ventilation system. Some defects were identified and attention was drawn to motivate their repair. Through this study, it has been verified that criteria of comfortable living space are met by the environment of the auditorium thanks to its supporting ventilation system. Despite the fact that simple criteria were relied upon the result are meaningful. The various experiment performed, most of which led to energy savings, have shown that a tweaking of the ventilation system is possible without hindering the livability of the environment provided by the auditorium. Overall it was concluded that tweaking the control algorithm of the ventilation system in a way to obtain 10% less circulation flow is recommended. This measure will not hinder the livability/comfort of the auditorium's environment. The important findings of this study are summarized in the executive summary and will not be presented in this section to avoid redundancy.

## **VII- Project Significance**

The project reveals the importance of investing into advanced and modern ventilation systems: most of the study was made possible thanks to the on-site sensors monitoring its functioning. The flexibility of the system was taken advantage of in a way that the system was tweaked in order to obtain energy savings while maintaining the comfort of the living space; and this is what the project partially aims to motivate. Given the fact that a building's ventilation system consumes about a 1/3 of its total energy requirements, any energy saving achieved at this level would be significant. The world is heading towards sustainability through generation of electricity from clean energy sources and conservation. The energy savings promoted by this project fall in the category of conservation and can motivate such energy saving measures implementation in the management of other buildings. It is therefore in total accordance with the higher objectives of this masters program.



## VIII- References

- [1] Christopher Y. Chaoa, M.P. Wana, Anthony K. Lawb. Ventilation performance measurement using constant concentration dosing strategy.
- [2] <http://www.energymanagertraining.com>, PDF document: The importance of energy efficiency in buildings.
- [3] World Business Council for Sustainable Development, Energy Efficiency in Buildings Summary Report.
- [4] Sherman MH, Matson N. Residential ventilation and energy characteristics. ASHRAE Transactions 1997;103:717–30.
- [5] Emmerich SJ, Persily AK. Energy impacts of infiltration and ventilation in U.S. Office buildings using multizone airflow simulation. In: Proceedings of IAQ and energy, New Orleans, LA; 1998. p. 191–203.
- [6] Bearg DW. Indoor air quality and HVAC systems. Boca Raton, FL: Lewis Publishers; 1993.
- [7] Andrew K. Persily, Manual for Ventilation Assessment in Mechanically Ventilated Commercial Buildings
- [8] ASHRAE, 1989, Ventilation for Acceptable Indoor Air Quality, Standard 62-1989, American Society of Heating, Refrigerating and Air-Conditioning Engineers, Inc., Atlanta..
- [9] ASHRAE, 1992, HVAC Systems and Equipment Handbook, American Society of Heating, Refrigerating and Air-Conditioning Engineers, Inc., Atlanta.
- [10] ASHRAE, 1993, Fundamentals Handbook, American Society of Heating, Refrigerating and Air Conditioning Engineers, Inc., Atlanta.
- [11] W.M.P. (Jeffrey) van der Pluijm, The Robusten and Effectiveness of Mechanical Ventilation in Air-Tight Dwellings
- [12] Rim, D., & Novoselac, A. (2010). Ventilation effectiveness as an indicator of occupant exposure to particles from indoor sources. *Building and Environment*, 45(5), 1214-1224. Elsevier Ltd. doi:10.1016/j.buildenv.2009.11.004
- [13] Petty, S. (1989). SUMMARY OF ASHRAE'S POSITION ON CARBON DIOXIDE CO<sub>2</sub> LEVELS IN SPACES. *Refrigeration And Air Conditioning*.
- [14] Unknown Author. The Importance of Energy Efficiency in Buildings. *The Bulletin on Energy Efficiency*, 6(4-6).
- [15] Federal Energy Management. (n.d.). Demand-Controlled Ventilation Using CO<sub>2</sub> Sensors. *Energy*.

- [16] European Consumer Protection Commission. (2003). *Environment and Quality of Life Ventilation , Good Indoor Air Quality. Indoor Air.*
- [17] Apte, M. G. (2006). A Review of Demand Control Ventilation. *Ashrae Standard*, (May).
- [18] Memarzadeh, F., & Manning, A. (n.d.). Thermal Comfort , Uniformity , and Ventilation Effectiveness in Patient Rooms : Performance Assessment Using Ventilation Indices. *Assessment.*
- [19] Dunn, W. A., Brager, G. S., Brown, K. A., Clark, D. R., Deringer, J. J., Hogeling, J. J., Int-hout, D., et al. (2004). ASHRAE STANDARD Thermal Environmental Conditions for Human Occupancy. *Ashrae Standard, 2004.*
- [20] Erdmann, C. A., Steiner, K. C., & Apte, M. G. (2002). INDOOR CARBON DIOXIDE CONCENTRATIONS AND SICK BUILDING SYNDROME SYMPTOMS IN THE BASE STUDY REVISITED : ANALYSES OF THE 100 BUILDING DATASET. *Indoor Air*, 443-448.

## IX- Appendices

The appendix files are located in a digital folder accompanying the digital version of this report. Some of the appendices are absolutely necessary to understand the results and the whole analysis. The other files are supporting documents for additional insight on the system or complementary understanding. A list of the files available is posted in this section of the report. Please contact SEEDS office to request the files.

- Appendix\_1\_Flow\_Meter\_User\_Manual\_ABB ACG550 PCR.pdf
- Appendix\_2\_VOC\_Sensor\_Greystone Air 300.pdf
- Appendix\_3\_Honeywell\_Temperature\_C70xx sensors.pdf
- Appendix\_4\_Honeywell\_CO2\_sensor\_C7632.pdf
- Appendix\_5\_Honeywell Humidity H763x.pdf
- Appendix\_6\_Honeywell Press P7640.pdf
- Appendix\_7\_UltraTech Air Flow Stations EDPTjr OM.pdf
- Appendix\_8\_AHU\_Specifications.pdf
- Appendix\_10- Honeywell TR21\_TR24 temp sensor.pdf
- Appendix\_12- AHU2\_Sequence\_of\_Operation.pdf
- Appendix\_13\_Image\_Auditorium.jpg
- Appendix\_14\_Image\_Auditorium.jpg
- Appendix\_15\_Image\_Auditorium.jpg
- Appendix\_16\_Image\_Auditorium.jpg
- Appendix\_17\_Image\_Auditorium.jpg
- Appendix\_18\_Image\_Auditorium.jpg
- Appendix\_19\_Image\_Auditorium.jpg
- Appendix\_20\_Image\_Auditorium.jpg
- Appendix\_21\_Image\_Auditorium.jpg
- Appendix\_22\_Image\_Auditorium.jpg
- Appendix\_23\_Image\_Auditorium.jpg
- Appendix\_24\_A-101 - Floor Plan Level Ground.pdf
- Appendix\_25 Understanding How to Calculate Enthalpy of Moist Air.pdf
- Appendix\_26\_Experiment\_1\_Test\_Period\_1\_9am\_to\_4pm\_Results.pdf

- Appendix\_27\_Experiment\_1\_Test\_Period\_1\_All\_Day\_Results.pdf
- Appendix\_28\_Experiment\_2\_Test\_Period\_1\_9am\_to\_4pm\_Results.pdf
- Appendix\_29\_Experiment\_2\_Test\_Period\_1\_All\_Day\_Results.pdf
- Appendix\_30\_Experiment\_3\_Test\_Period\_1\_9am\_to\_4pm\_Results.pdf
- Appendix\_31\_Experiment\_3\_Test\_Period\_1\_All\_Day\_Results.pdf
- Appendix\_32\_Experiment\_4\_Test\_Period\_1\_9am\_to\_4pm\_Results.pdf
- Appendix\_33\_Experiment\_4\_Test\_Period\_1\_All\_Day\_Results.pdf
- Appendix\_34\_Experiment\_5\_Test\_Period\_1\_9am\_to\_4pm\_Results.pdf
- Appendix\_35\_Experiment\_5\_Test\_Period\_1\_All\_Day\_Results.pdf
- Appendix\_36\_Experiment\_6\_Test\_Period\_1\_9am\_to\_4pm\_Results.pdf
- Appendix\_37\_Experiment\_6\_Test\_Period\_1\_All\_Day\_Results.pdf
- Appendix\_38\_Experiment\_7\_Test\_Period\_1\_9am\_to\_4pm\_Results.pdf
- Appendix\_39\_Experiment\_7\_Test\_Period\_1\_All\_Day\_Results.pdf
- Appendix\_40\_Experiments\_Comparison\_Absolute\_Trial\_1.pdf
- Appendix\_41\_Experiments\_Comparison\_Relative\_Trial\_1.pdf
- Appendix\_42\_Experiment\_1\_Test\_Period\_2\_Results\_9am\_to\_4pm.pdf
- Appendix\_43\_Experiment\_1\_Test\_Period\_2\_Results\_All\_Day.pdf
- Appendix\_44\_Experiment\_2\_Test\_Period\_2\_Results\_9am\_to\_4pm.pdf
- Appendix\_45\_Experiment\_2\_Test\_Period\_2\_Results\_All\_Day.pdf
- Appendix\_46\_Experiment\_3\_Test\_Period\_2\_Results\_9am\_to\_4pm.pdf
- Appendix\_47\_Experiment\_3\_Test\_Period\_2\_Results\_All\_Day.pdf
- Appendix\_48\_Experiment\_4\_Test\_Period\_2\_Results\_9am\_to\_4pm.pdf
- Appendix\_49\_Experiment\_4\_Test\_Period\_2\_Results\_All\_Day.pdf
- Appendix\_50\_Experiment\_5\_Test\_Period\_2\_Results\_9am\_to\_4pm.pdf
- Appendix\_51\_Experiment\_5\_Test\_Period\_2\_Results\_All\_Day.pdf
- Appendix\_52\_Experiment\_6\_Test\_Period\_2\_Results\_9am\_to\_4pm.pdf
- Appendix\_53\_Experiment\_6\_Test\_Period\_2\_Results\_All\_Day.pdf
- Appendix\_54\_Experiment\_7\_Test\_Period\_2\_Results\_9am\_to\_4pm.pdf
- Appendix\_55\_Experiment\_7\_Test\_Period\_2\_Results\_All\_Day.pdf
- Appendix\_56\_Experiments\_Comparison\_Absolute\_Trial\_2.pdf
- Appendix\_57\_Experiments\_Comparison\_Relative\_Trial\_2.pdf
- Appendix\_58\_Automatic\_Day\_1\_Results\_9am\_to\_4pm.pdf
- Appendix\_59\_Automatic\_Day\_1\_Results\_All\_Day.pdf
- Appendix\_60\_Automatic\_Day\_2\_Results\_9am\_to\_4pm.pdf
- Appendix\_61\_Automatic\_Day\_2\_Results\_All\_Day.pdf
- Appendix\_62\_Automatic\_Day\_3\_Results\_9am\_to\_4pm.pdf
- Appendix\_63\_Automatic\_Day\_3\_Results\_All\_Day.pdf
- Appendix\_64\_Automatic\_Day\_4\_Results\_9am\_to\_4pm.pdf
- Appendix\_65\_Automatic\_Day\_4\_Results\_All\_Day.pdf
- Appendix\_66\_Automatic\_Day\_5\_Results\_9am\_to\_4pm.pdf
- Appendix\_67\_Automatic\_Day\_5\_Results\_All\_Day.pdf
- Appendix\_68\_Auto\_Day\_Results\_2\_Comparison.pdf